

# **An Open Cloud Computing Interface Status Update (and Roadmap Dartboard!)**

**OMG, Long Beach, December 10, 2009**

**Craig A. Lee  
President, OGF, [www.ogf.org](http://www.ogf.org)**

# Overview



- Some Context of Cloud Events
- OCCI Status Update
- National Cloud Roadmap Dartboard
  - A Trajectory of National Cloud Deployments
  - Issues:
    - Technical, Legal/Organizational, Landscape
  - Draft Roadmap “Dartboard”
    - Deployment, Development & Risk Mitigation, Research
- Wrap-up

# Context



- Series of meetings and workshops
  - Enterprise Cloud Conference, Open Group, Feb. 3, San Diego
  - SATCCI, OMG, March 23, Arlington/Crystal City
  - Cloud Standards Summit, OMG, July 13, Arlington/Ballston
  - Standards for the US Cloud Storefront, NCOIC, Sept. 21, Fairfax
- Creation of *cloud-standards.org*
  - Informal group for coordination across cloud SDOs
- Wide interest from federal agencies
  - GeoCloud NSF Workshop, Indianapolis, Sept. 17-18
  - GeoINT Technical Exch. Meeting hosted at MITRE, McLean VA, Sept. 24
  - Ground Systems Architecture Workshop (GSAW), March 1-4, 2010
- Multiple national cloud initiatives
  - US Cloud Storefront, Japanese Kasumigaseki, UK G-Cloud
- Development of potential standards
  - OCCI, vCloud, delta-Cloud, Fujitsu API, Simple-cloud, ...

# Open Cloud Computing Interface



- Focus on interoperable IaaS Cloud API: [www.occ-i-wg.org](http://www.occ-i-wg.org)
- Goal: Creation of a simple and RESTful API
  - Simple and very extensible: ~15 commands
- Solid community interest: 160 members on mailing list
  - Industry: Rackspace, GoGrid, Sun, RESERVOIR, ...
  - Academia: UCMadrid (OpenNebula), SLA@SOI w/Intel, ...
  - Service providers: CohesiveFT, RabbitMQ, ...
  - End users, developers: Australian Online Solutions
  - OGF IP umbrella for copyrights, patents, trademarks
- OCCi collaborating with:
  - DMTF: Work Registry
  - SNIA: Cloud storage joint meetings
  - All others in [cloud-standards.org](http://cloud-standards.org)



# OCCI from 20,000 feet

- Protocol
- Lightweight, extensible
- Format-agnostic
- Built on HTTP, RESTful

Create: HTTP POST

Retrieve: HTTP GET

Update: HTTP GET & HTTP PUT

Delete: HTTP DELETE

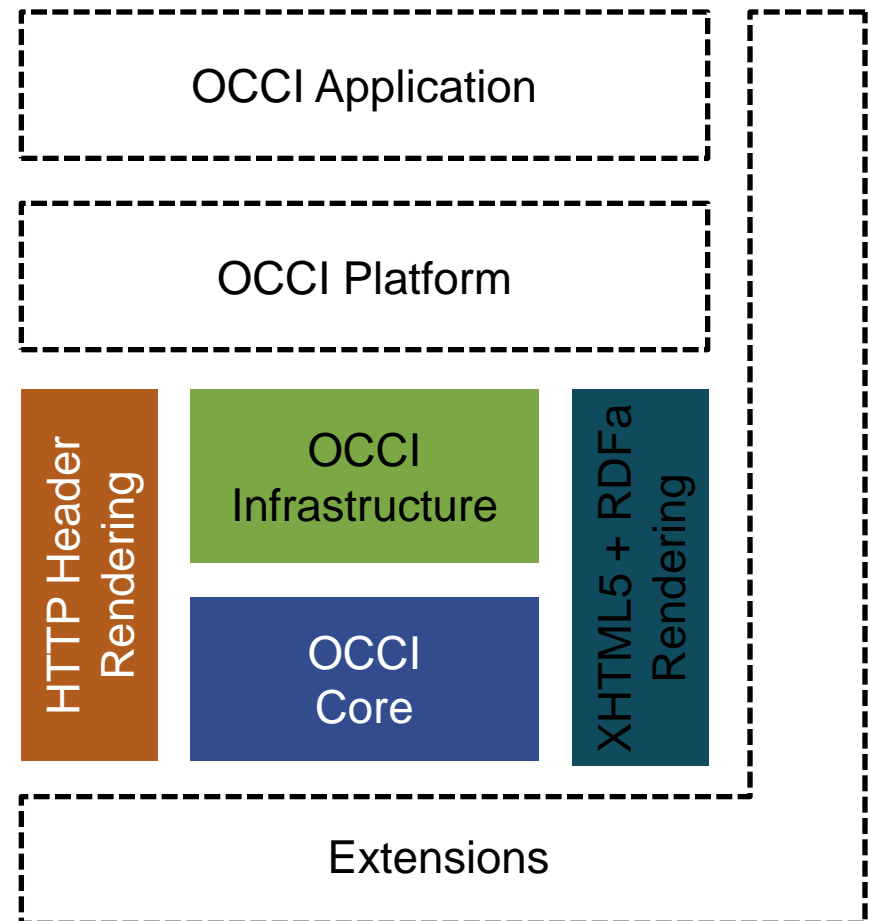

# OCCI from 5,000 feet

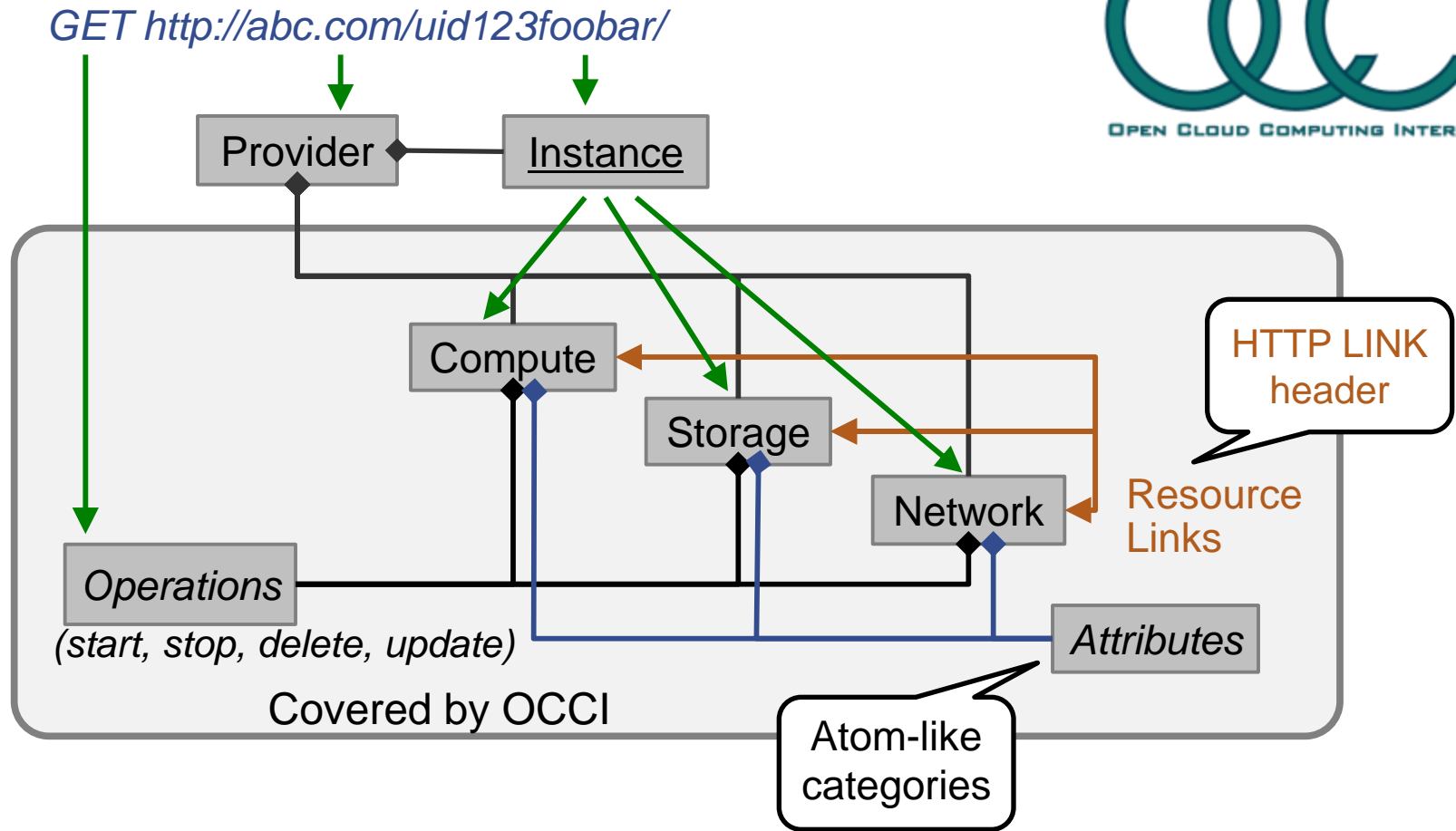

# OCCI Up Close

REQUEST

```
> GET /us-east/webapp/vm01 HTTP/1.1
> User-Agent: occi-client/1.0 (linux) libcurl/7.19.4 OCCI/1.0
> Host: cloud.example.com
> Accept: */*
>
```

RESPONSE

```
< HTTP/1.1 200 OK
< Date: Sat, 10 Oct 2009 12:56:51 GMT
< Content-Type: application/ovf
< Link: </us-east/webapp/vm01;start>;
  < rel="http://purl.org/occi/action/start";
  < title="Start"
< Link: </us-east/webapp/build.pdf>;
  < rel="related";
  < title="Documentation";
  < type="application/pdf"
< Category: compute;
  < label="Compute Resource";
  < scheme="http://purl.org/occi/kind/"
< Server: occi-server/1.0 (linux) OCCI/1.0
< Connection: close
<
< <?xml version="1.0" encoding="UTF-8"?>
< <Envelope xmlns:xsi="http://www.w3.org/2001/XMLSchema-instance"
  < xmlns:ovf="http://schemas.dmtf.org/ovf/envelope/1"
  < xmlns="http://schemas.dmtf.org/ovf/envelope/1"
  < xml:lang="en-US"
< ...
```

Get the resource,  
in whatever  
format

It's in OVF  
format

You can  
"start" it

Related  
"documentation"

It's a  
"compute"  
resource

The OVF  
payload

# Other APIs / Interfaces

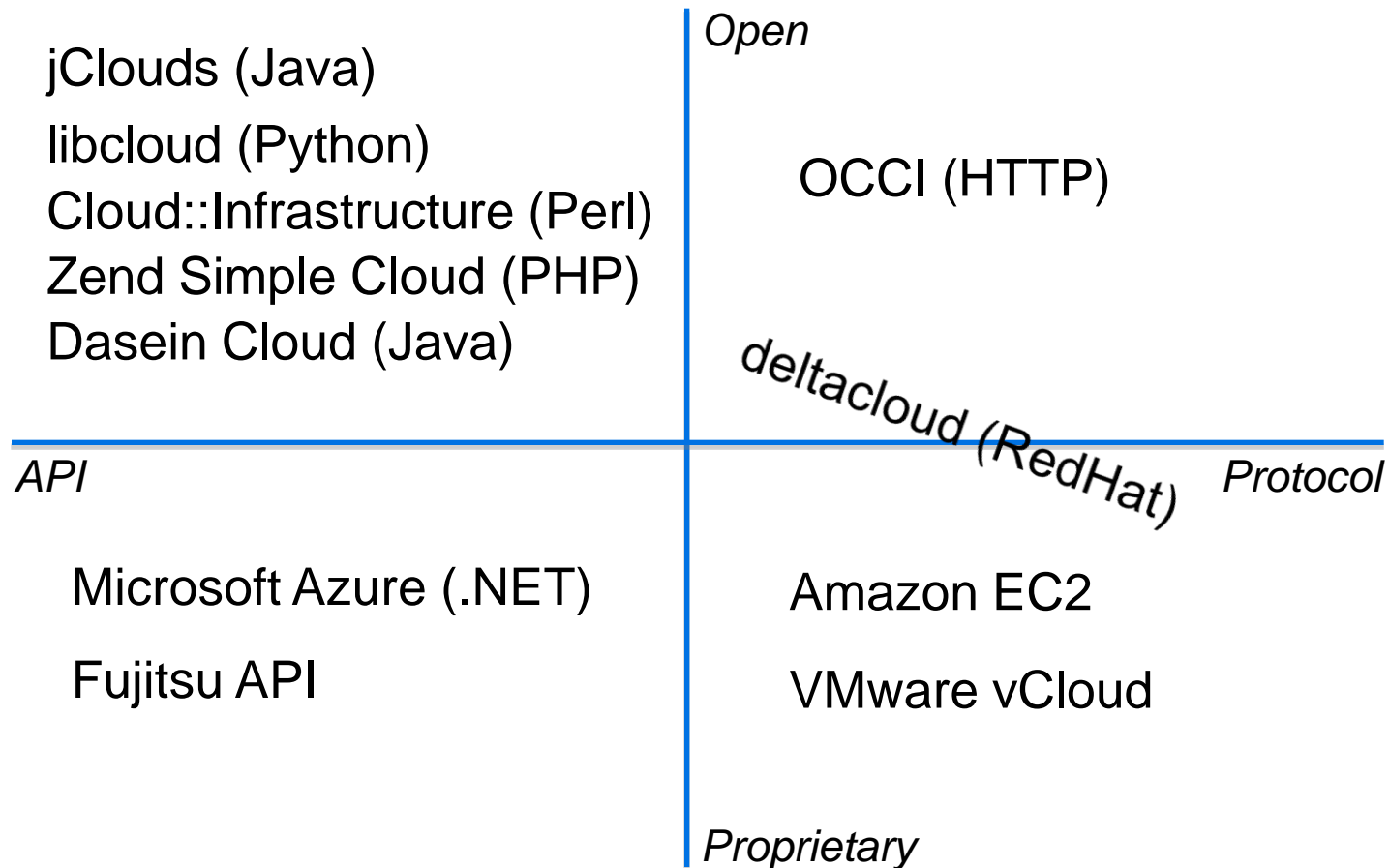

# OCCI Status

- Four Documents: *Submitted to OGF Editor*
  - The OCCI Core & Models
  - The OCCI Infrastructure Models
  - OCCI XHTML5 Rendering
  - OCCI HTTP Header Rendering
- Please Comment: [http://www.ogf.org/gf/docs/?public\\_comment](http://www.ogf.org/gf/docs/?public_comment)
  - Download documents and upload comments (after OGF Editor has officially put the documents into the 60-day Public Comment period)
- Four implementations
  - OpenNebula (existing)
  - Istituto Nazionale di Fisica Nucleare (INFN) (existing)
  - SLA@SOI (planned)
  - anonymous
- Planned Future Work
  - Extensions:
    - Snapshots, Advanced Reservations, Billing
  - PaaS-level capabilities



# Upcoming Events!

- **Cloudscape II**
  - Brussels, February 22-23, 2010
  - Cloud/Grid e-infrastructures
  - Openness & Interoperability
  - Organized by OGF-Europe
- **OGF-28**
  - Munich, March 15-19, 2010
  - “Future of Distributed Computing Infrastructures (DCIs)”
  - In coordination with
    - OGF-Europe
    - Open Geospatial Consortium
    - Cloud Security Alliance



# Next Steps?

- How Will National Cloud Deployment Progress?
  - How will it drive development & standards?
  - How could it facilitate harmonization or shake-out?
- A draft deployment/standards roadmap needed!
  - A “dartboard” to provoke discussion
- What is the likely trajectory of these efforts?
  - Top-Down deployment of “national public cloud”
    - Appealing from “end-goal” perspective
    - Difficult to get true adoption except for simple functions
  - Bottoms-Up deployment of “organizational clouds”
    - Realistic starting-point for many organizations
    - Much easier to control policy, security, risk, liability

# A National Cloud Deployment Trajectory

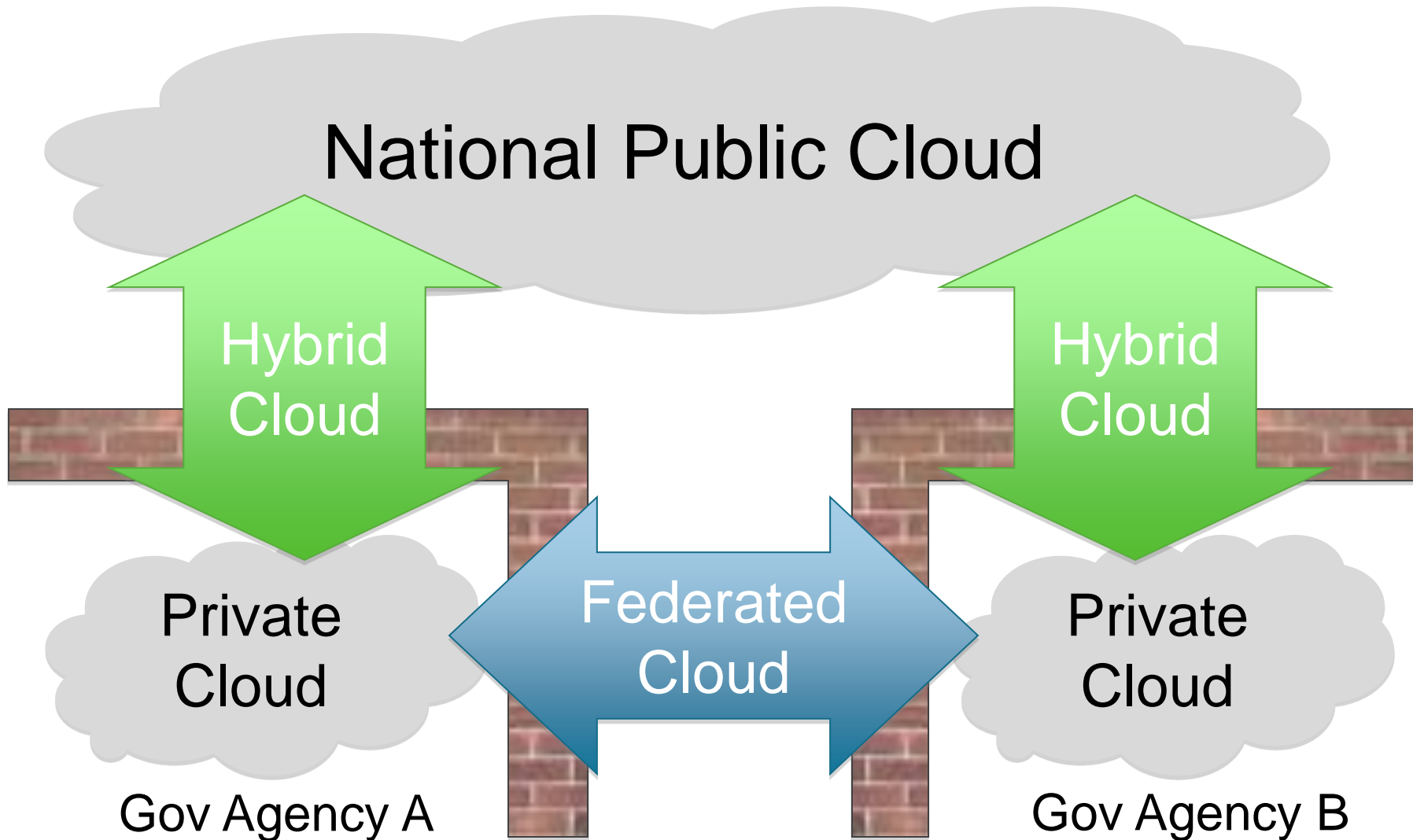

# Progression of Issues & Concerns

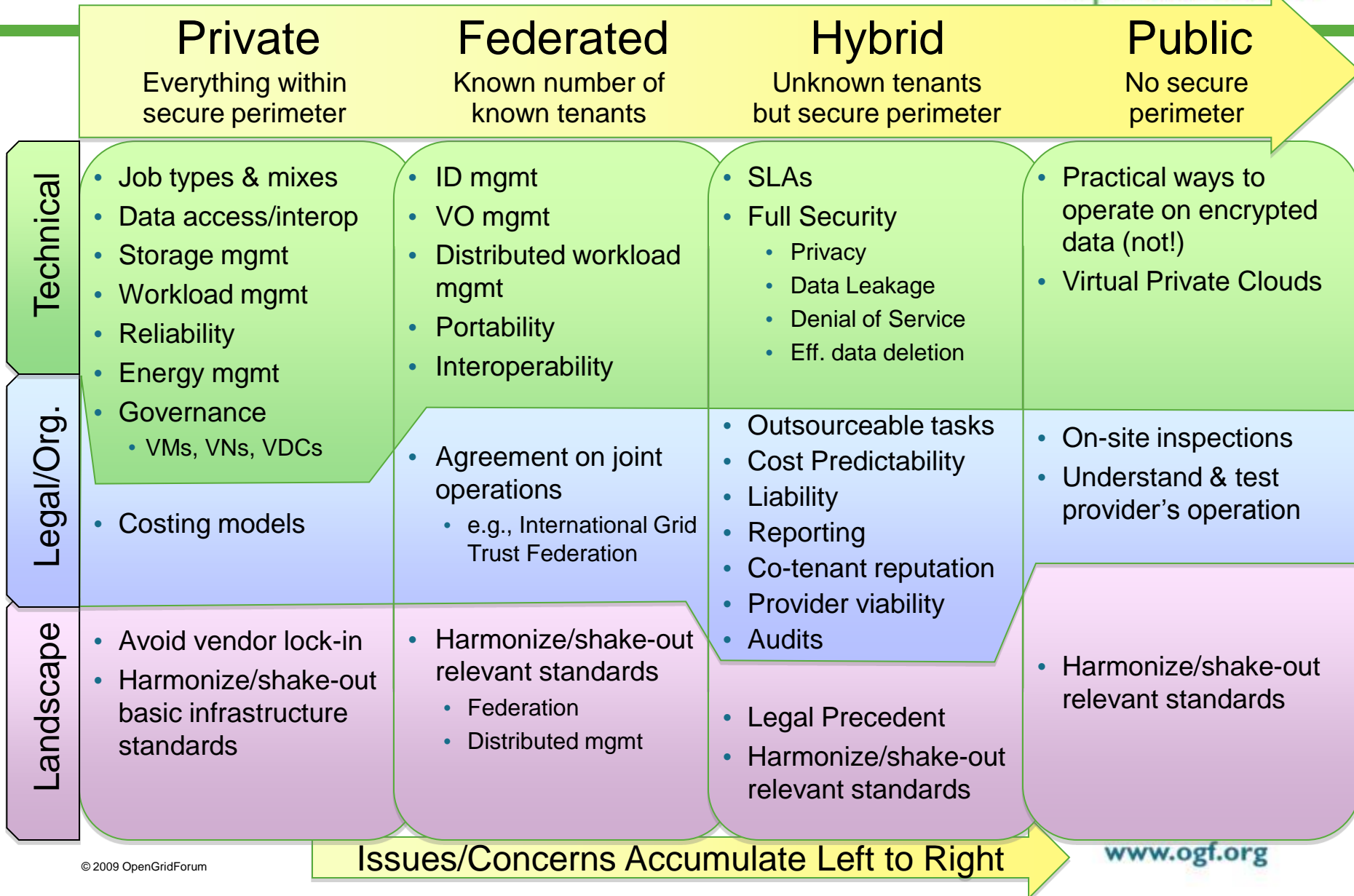

Issues/Concerns Accumulate Left to Right

# Draft Roadmap Dashboard



## Phase I

## Phase II

## Phase III

## Phase IV

	Phase I	Phase II	Phase III	Phase IV
Deployment	<ul style="list-style-type: none"> <li>Existing IaaS processing and storage</li> <li>ID mgmt</li> </ul>	<ul style="list-style-type: none"> <li>VO mgmt</li> <li>Dist Wrkld Mgmt</li> <li>Data access &amp; interop</li> </ul>	<ul style="list-style-type: none"> <li>Hybrid infrastructure</li> <li>SLAs</li> <li>Auditing/Monitoring/Reporting</li> </ul>	<ul style="list-style-type: none"> <li>VN, VDC, VPC</li> <li>Secure operations</li> <li>Organizations deprecate their own infrastructures</li> </ul>
Development & Risk Mitigation	<ul style="list-style-type: none"> <li>Develop common, extensible data arch &amp; semantics</li> <li>Testbed Bake-off</li> <li>Reliability practices</li> <li>Workload mgmt</li> <li>Costing models</li> <li>Joint practices</li> </ul>	<ul style="list-style-type: none"> <li>Energy Mgmt</li> <li>SLAs at scale</li> <li>PaaS capabilities</li> <li>Auditing/Reporting mechanisms</li> <li>Regulatory support</li> <li>Set legal precedent</li> </ul>	<ul style="list-style-type: none"> <li>Cloud DNS</li> <li>VN, VDC, VPC demonstration</li> <li>Various security tools</li> </ul>	<ul style="list-style-type: none"> <li>Virtual Enterprise/Mission Support</li> <li>Autonomic systems</li> </ul>
Research	<ul style="list-style-type: none"> <li>SLAs &amp; governance to support job mix</li> <li>Event Notification at scale</li> <li>Various security issues</li> </ul>	<ul style="list-style-type: none"> <li>Naming – Cloud DNS</li> <li>VN, VDC, VPC mgmt</li> <li>Autonomic policy enforcement</li> </ul>	<ul style="list-style-type: none"> <li>Virtual Missions</li> <li>Virtual Enterprises</li> <li>Encrypted operation</li> </ul>	<ul style="list-style-type: none"> <li>Quantum computing</li> </ul>

# Scenarios from an NCI to drive and prioritize development



1. A virtual machine image can be transferred between, say, Supplier A's data center running Microsoft Azure, and Supplier B's facility using VMware or Zen.
2. A cross supplier brokerage service can be established enabling the discovery of available capacity and the ability to agree a 'spot contract' for using it.
3. There are mechanisms that enable secure access to data and business logic across different vendor's data-centers, used in conjunction with 2.
4. It is straightforward to transfer a workload 'out' and 'back in' – with confidence in information security and service standards.
5. Service management teams can maintain service delivery standards even where workload is switch between different suppliers data centers; enabled by standards for svc monitoring; problem detection/resolution.
6. Many legacy applications can be transferred into the cloud environment , and then dynamically allocated to available capacity -- enabled by standards for tools that automate migration of more complex legacy apps (eg mainframe, 3 tier etc) into the virtualized cloud environment in a standard way.

# A Scientific and Operational Grand Challenge

Basic Science, Computational Science, Data Access, On-Demand Resources

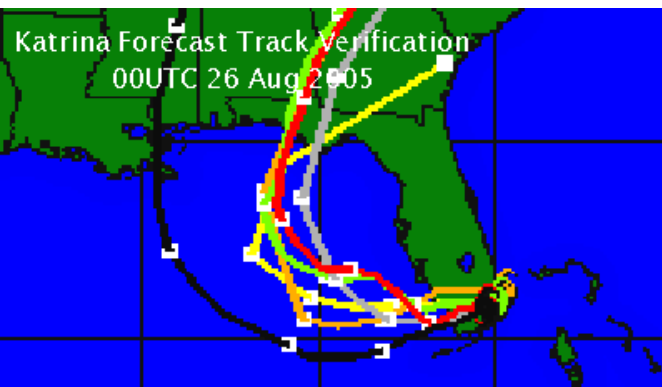
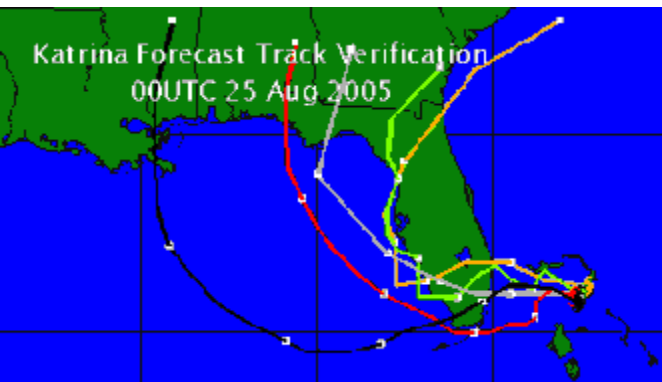
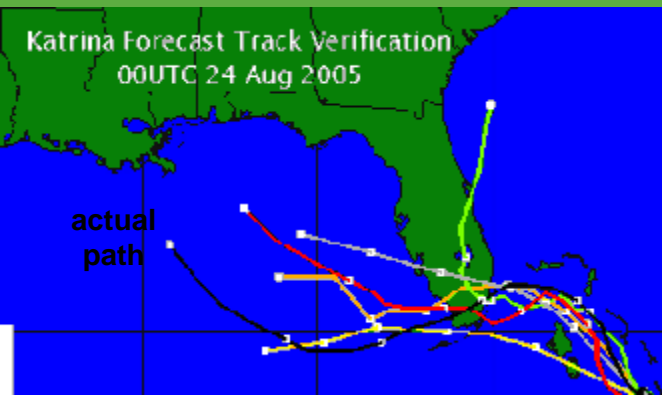

**5**  
days  
out

**2**

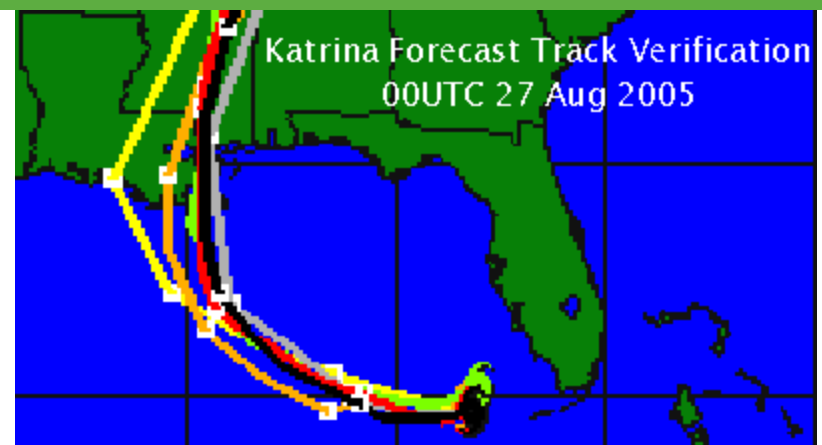

**4**

**1**

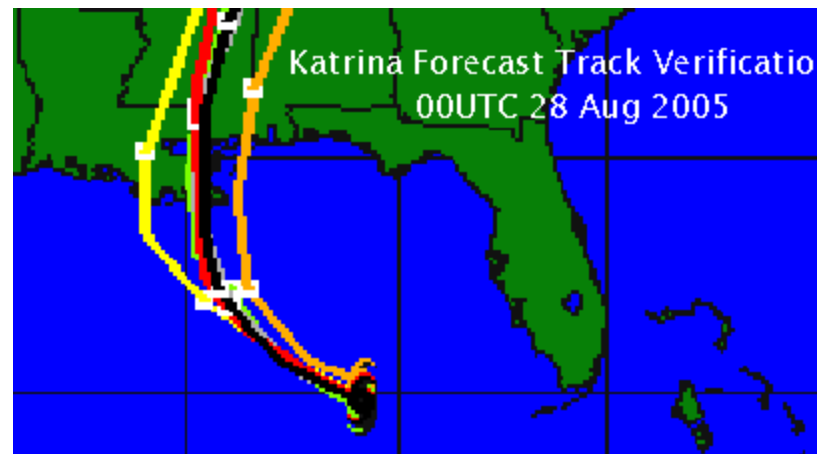

**3**

Philip Bogden, (Past) SCOOP Program Director  
[scoop.sura.org/documents/MTS\\_Journal\\_Article\\_Final.pdf](http://scoop.sura.org/documents/MTS_Journal_Article_Final.pdf)

SURA Coastal Ocean Observing  
and Prediction (SCOOP) Program

# Summary & Take-Home Message



- OCCI in Public Comment Period (soon!)
  - Series of demonstrations possible to harmonize/shake-out existing/developing standards
- Argued that bottoms-up approach of evolving from private to public clouds acknowledges and leverages how the real-world works
- Draft roadmap “dartboard” presented
  - Deployment, Development /Risk Mitigation, Research
  - Hopefully discussion provoked!
- ***We must agree on how to drive progress***

*Thank You, lee@aero.org*

# Back-ups

# What Must Standards Organizations Do to Achieve Portability and Interoperability?



- ***Drive Progress***
- Build Critical Mass of Key Stakeholders
  - Continual polling and coordination across the community
- Forge agreement on:
  - Clear Goals
  - Clear Schedule (“time-box” the process)
  - Clear Responsibilities
  - Proper Provisioning of the Effort
- Major Stakeholders Must Contribute:
  - Time, Money & ***People***
  - Technical staff must engage to do the real technical work
  - The more people “invested”, the more your agenda addressed!
  - Cannot be a “marketing” organization
- Deliver ROI to the Stakeholders
  - ***Targeted Projects on Key Issues***