

Dynamic Deployment and Configuration

Akiko Yano, Yoshiaki Tamura
Northeastern University

Intro to Software Components

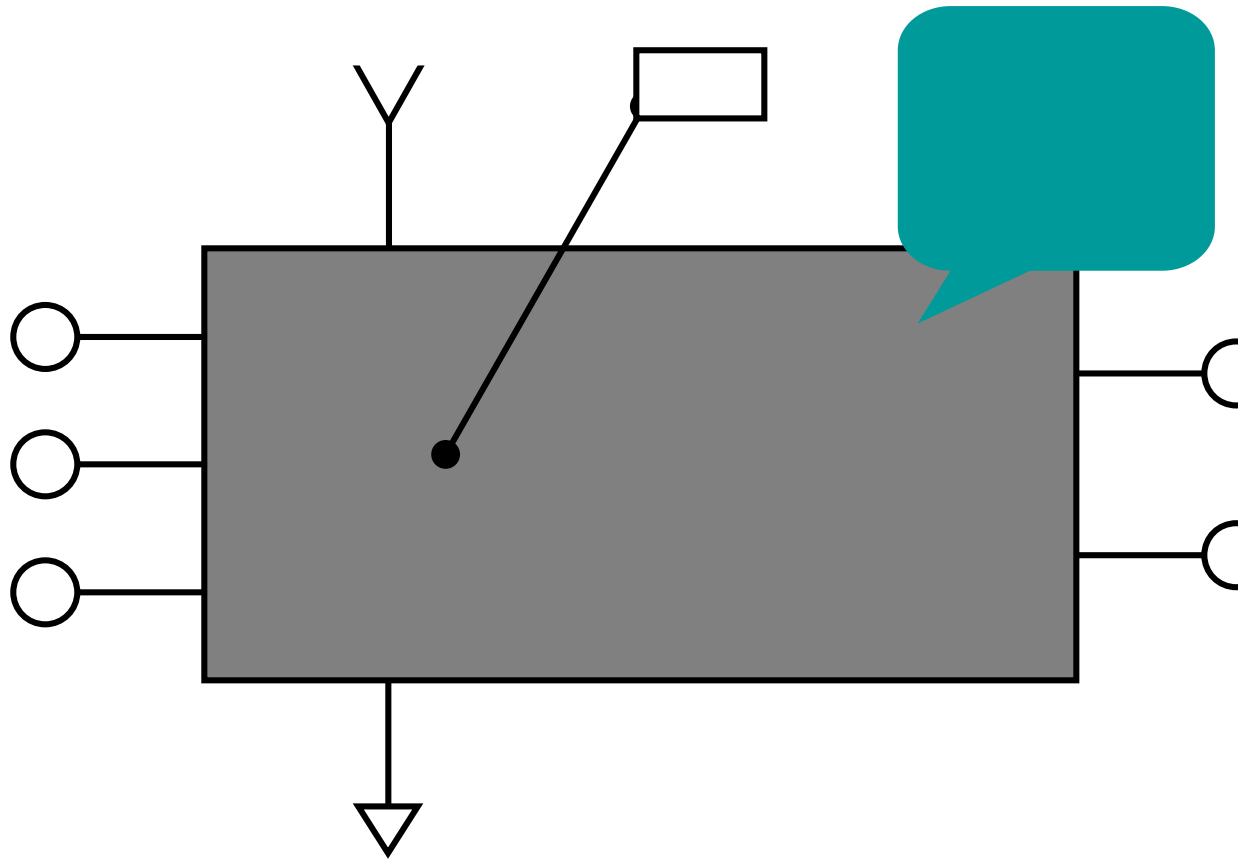

Intro to Software Components

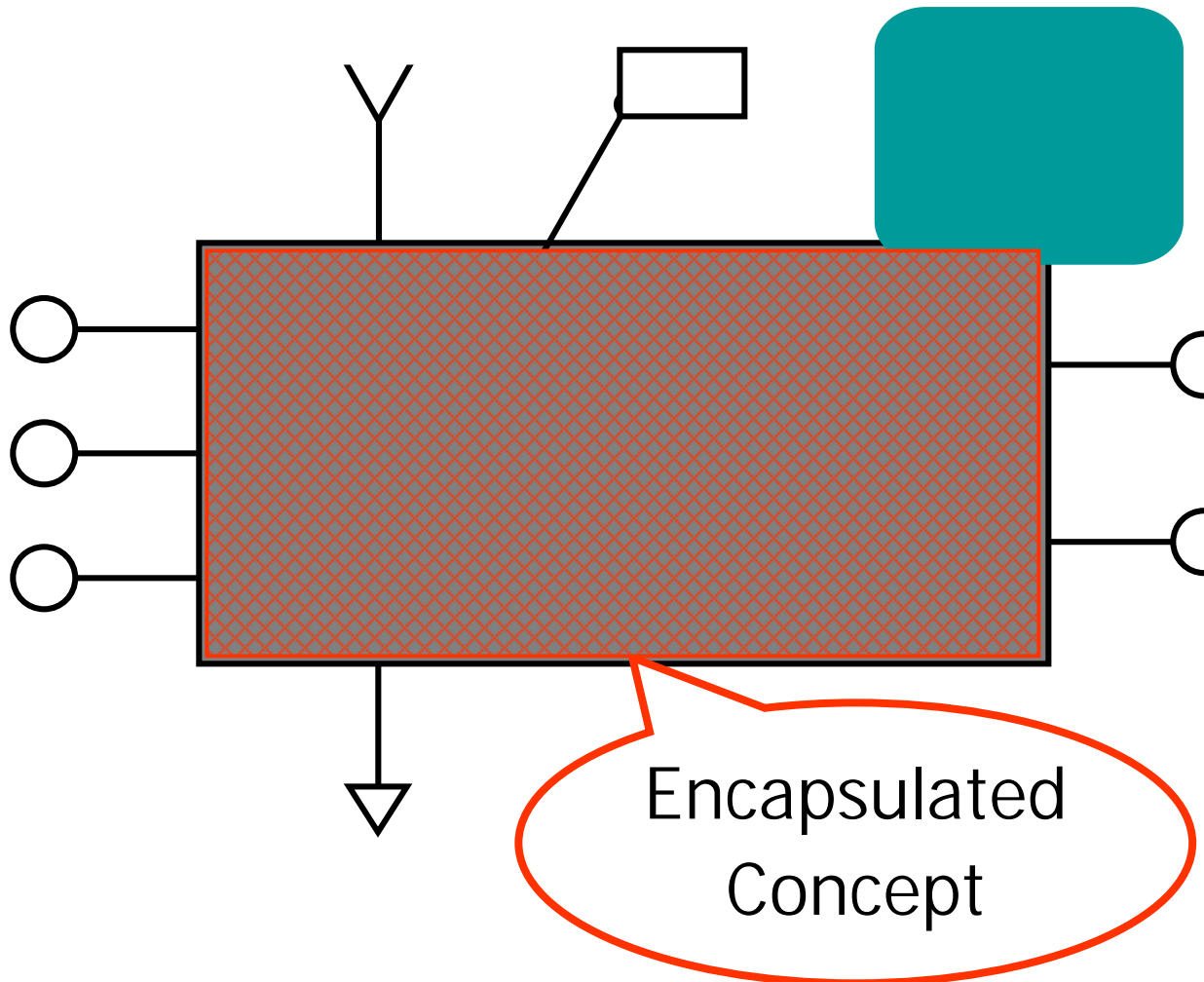

Intro to Software Components

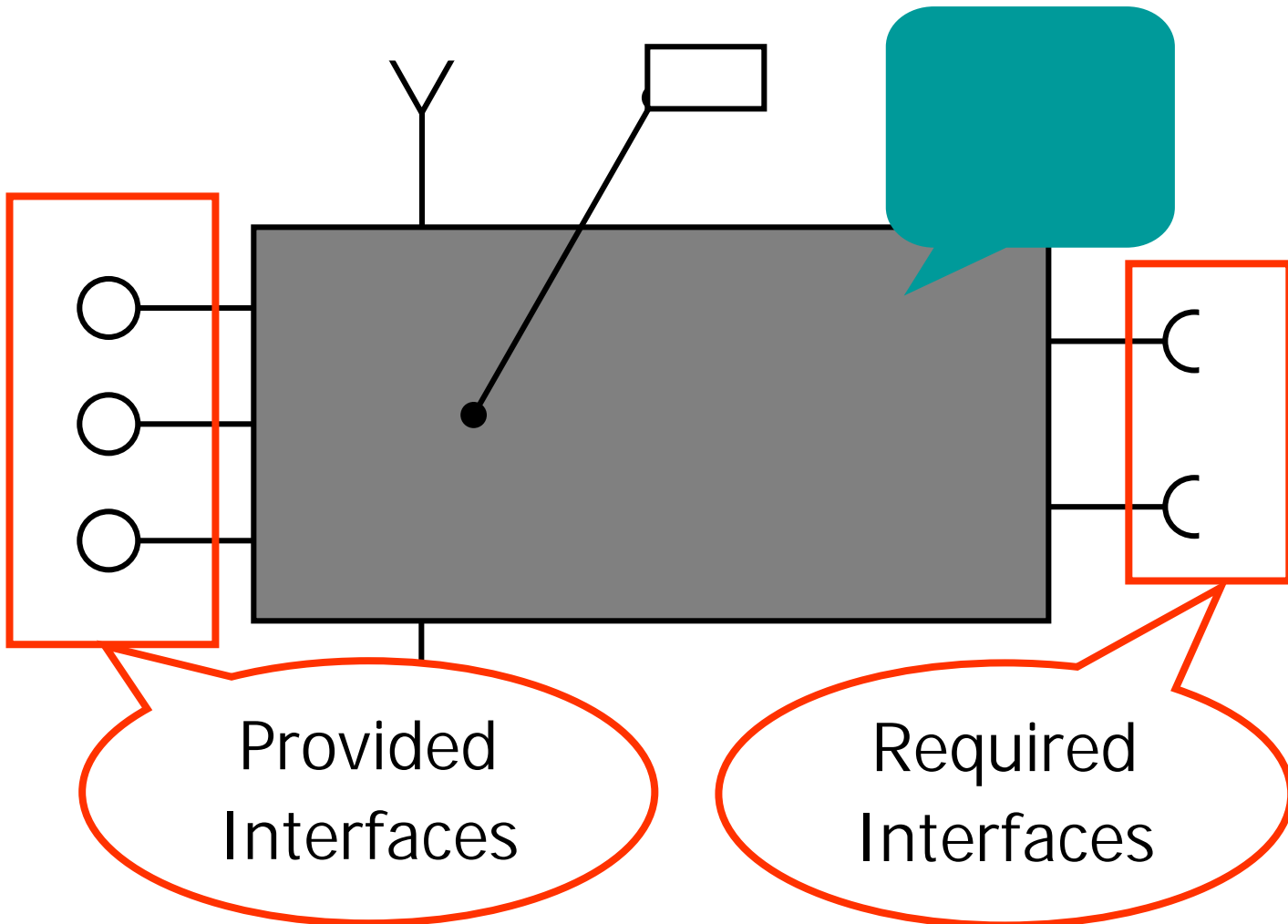

Intro to Software Components

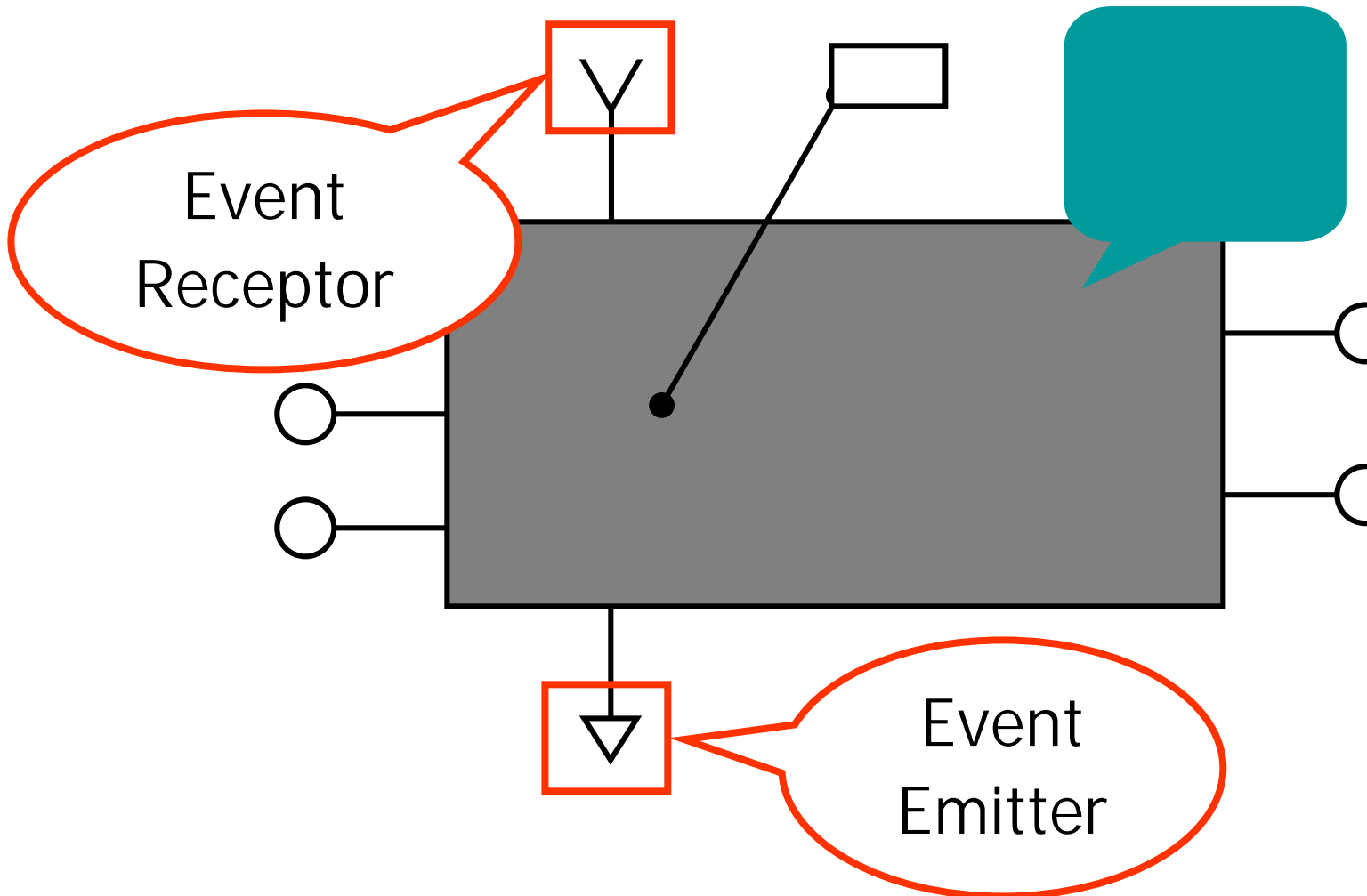

Intro to Software Components

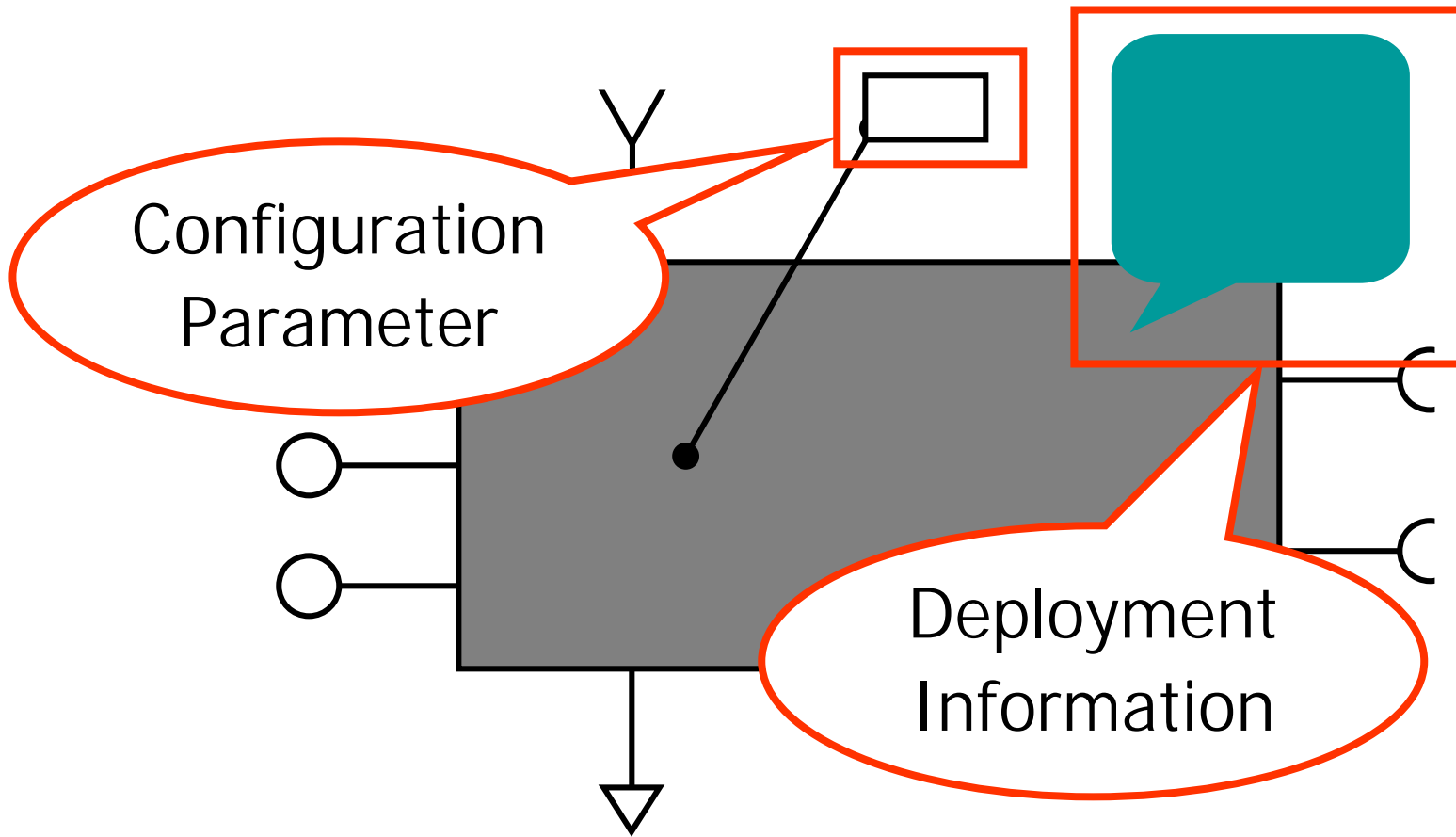

Component & Artifact

Logical

Physical

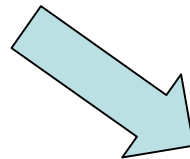
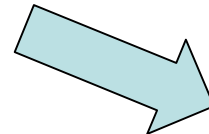

Components are implemented by (multiple) Artifacts

Deployment & Configuration

Installation

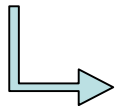

Configuration

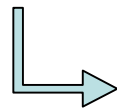

Planning

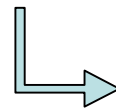

Preparation

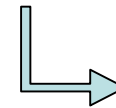

Launch

Flow of actions in the original
Deployment and Configuration
OMG Specification



Dynamic Reconfiguration Required

Example: Software-Defined Radio

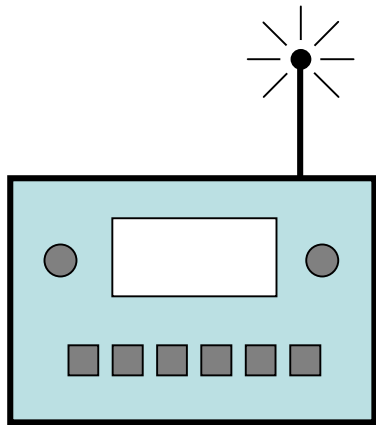

Transmission
Characteristic 1

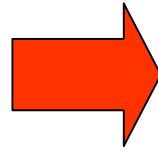

Transition
within
Milliseconds
required

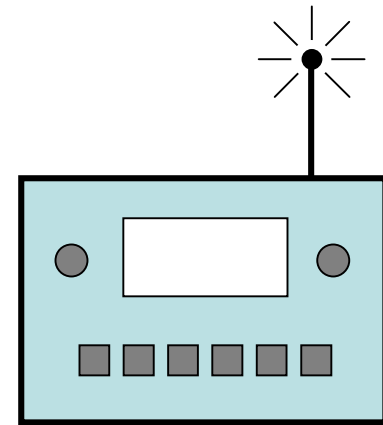

Transmission
Characteristic 2

Dynamic Deployment & Configuration

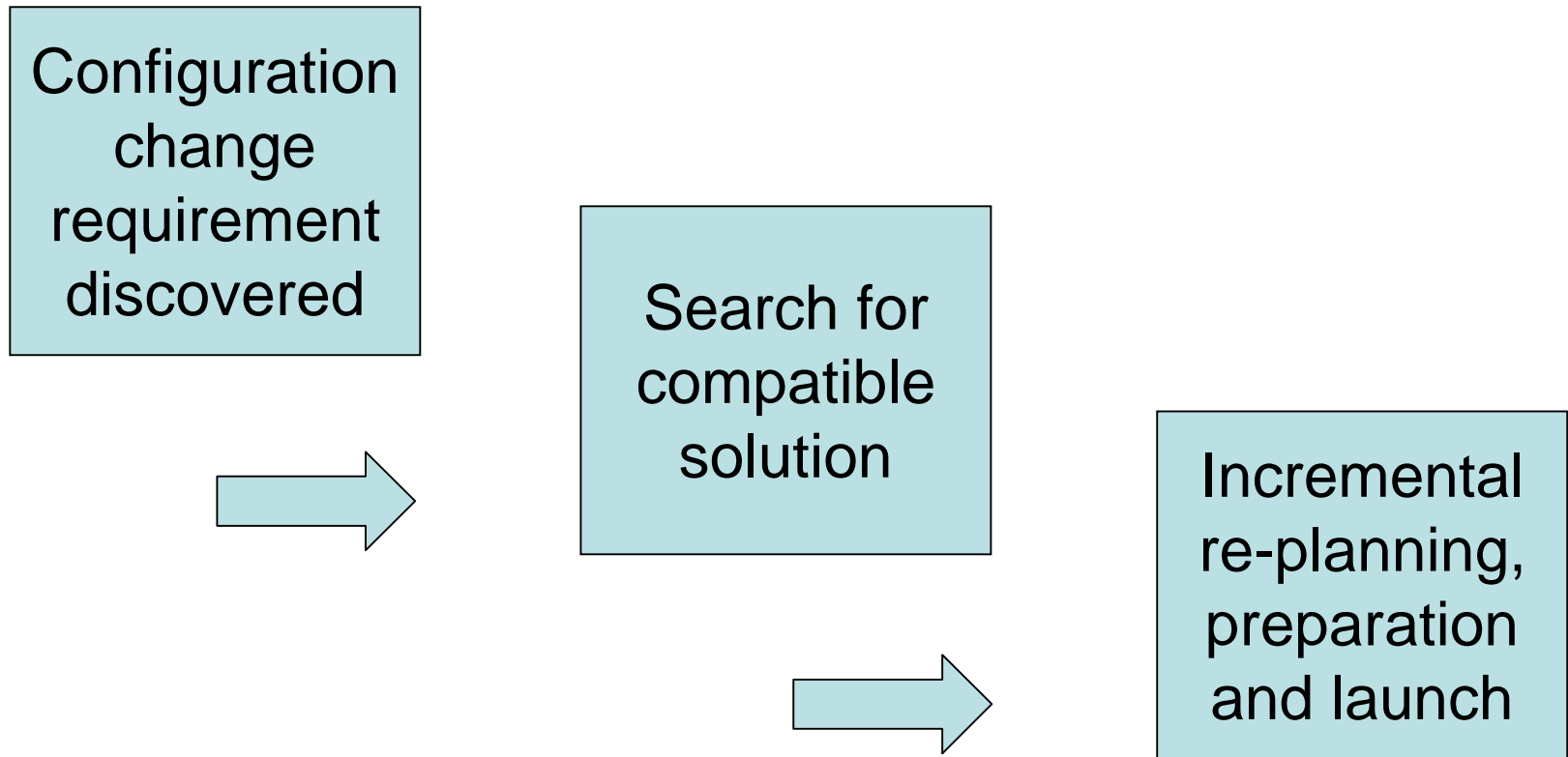

Features of Dynamic D&C

- Role
 - Represent functional requirements
- Morphological Approach
 - Used by the Planner to find the appropriate artifact
- Incremental Deployment
 - Reconfiguration & Deployment is done only for the additional artifacts
 - The Target environment can be updated while running

Introduction of Role

- Resides in Computation Independent Model (CIM)
- Represents an abstract functionality of a component
- The Target environment or the Host
 - Requests a new Role to fulfill the requirement
 - Does not request a component
- Target doesn't have to know the mapping of a Role, component and artifact
 - Planner will solve the mapping among them

Morphological Box

- Contains all of the potential solutions of the given problem
- Enables us to make discoveries and inventions in a systematic way
- All the solutions contained are evaluated
- The suitable solution is selected and applied

[Reference] Fritz Zwicky,
Discovery, Invention, Research
Through the Morphological Approach

Morphological Box for Dynamic D&C

[Parameters]

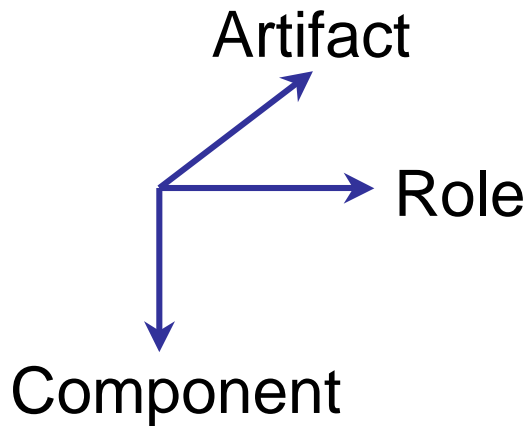

[Example]

Role1 → Component2 → Artifact2

[Box tailored for one Target]

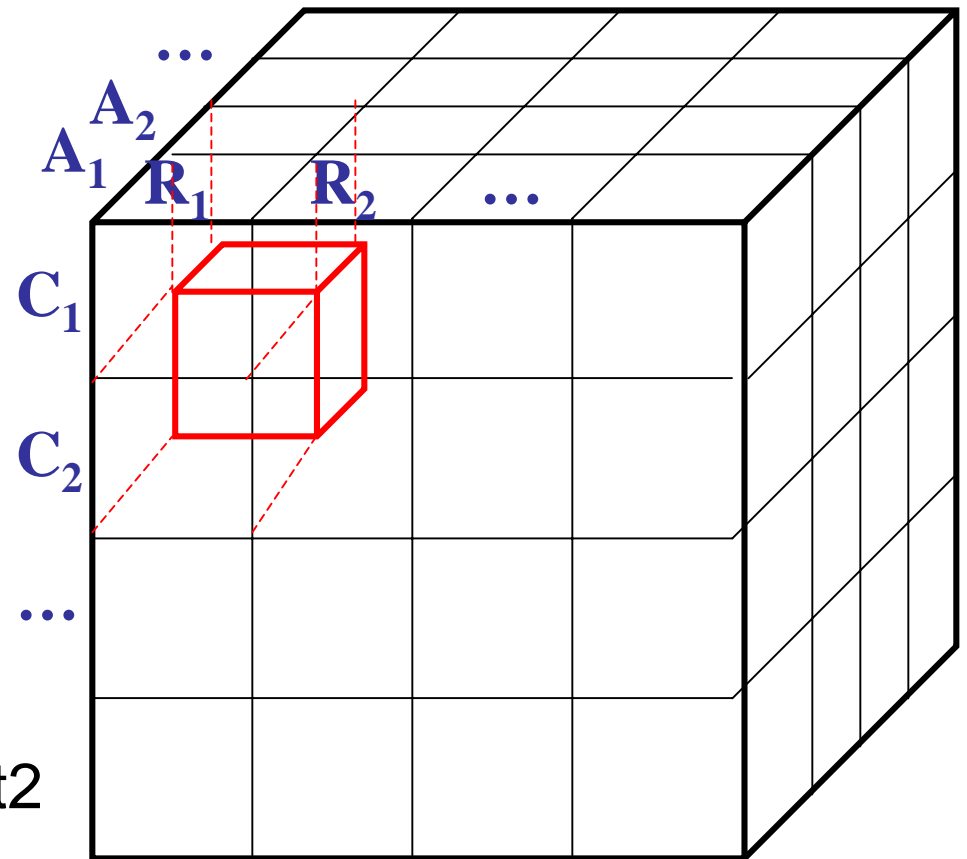

Search of the Logical Solution Space

Required Roles

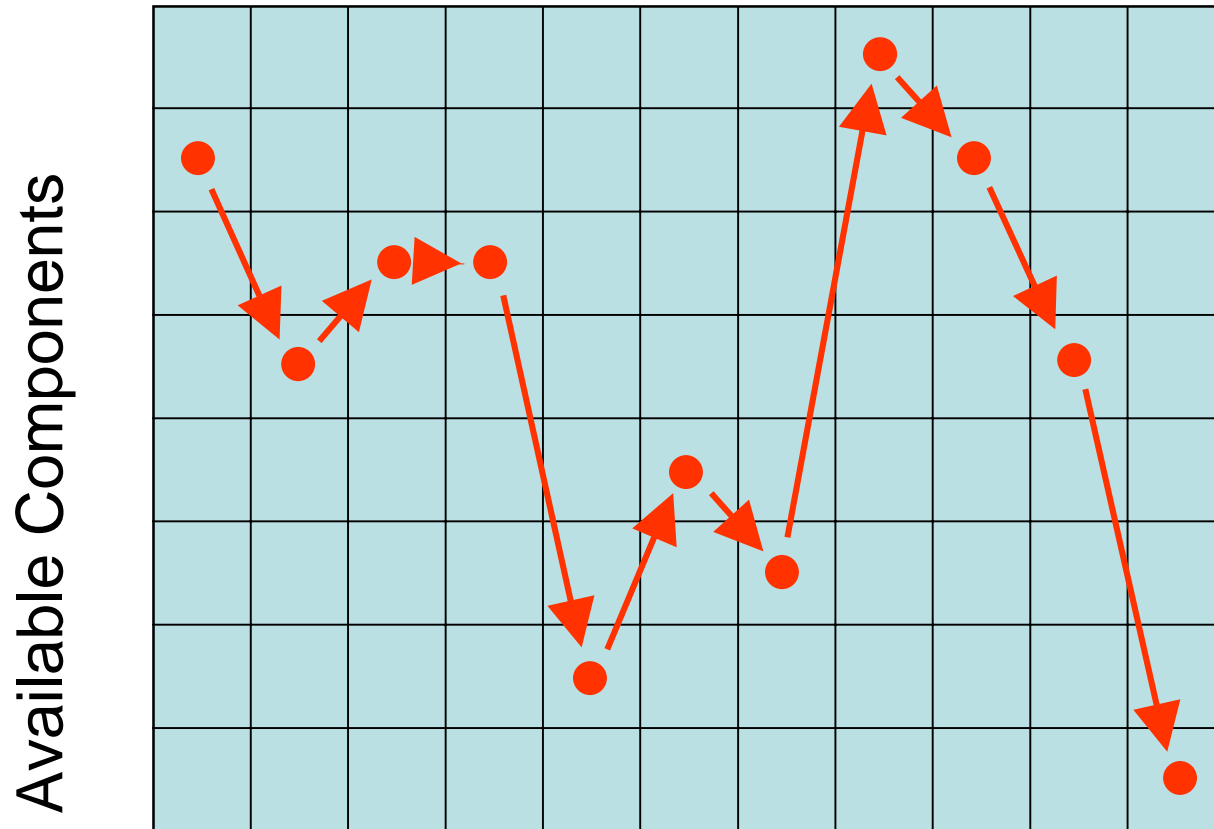

Search of the Logical Solution Space

- Component compatibility is determined by comparing the ComponentInterfaceDescriptors
- The compatibility is ranked by how good the interfaces match
- All required interfaces must be satisfied

The component has more provided interfaces than required

The component with exactly matched interfaces

Search of the Physical Solution Space

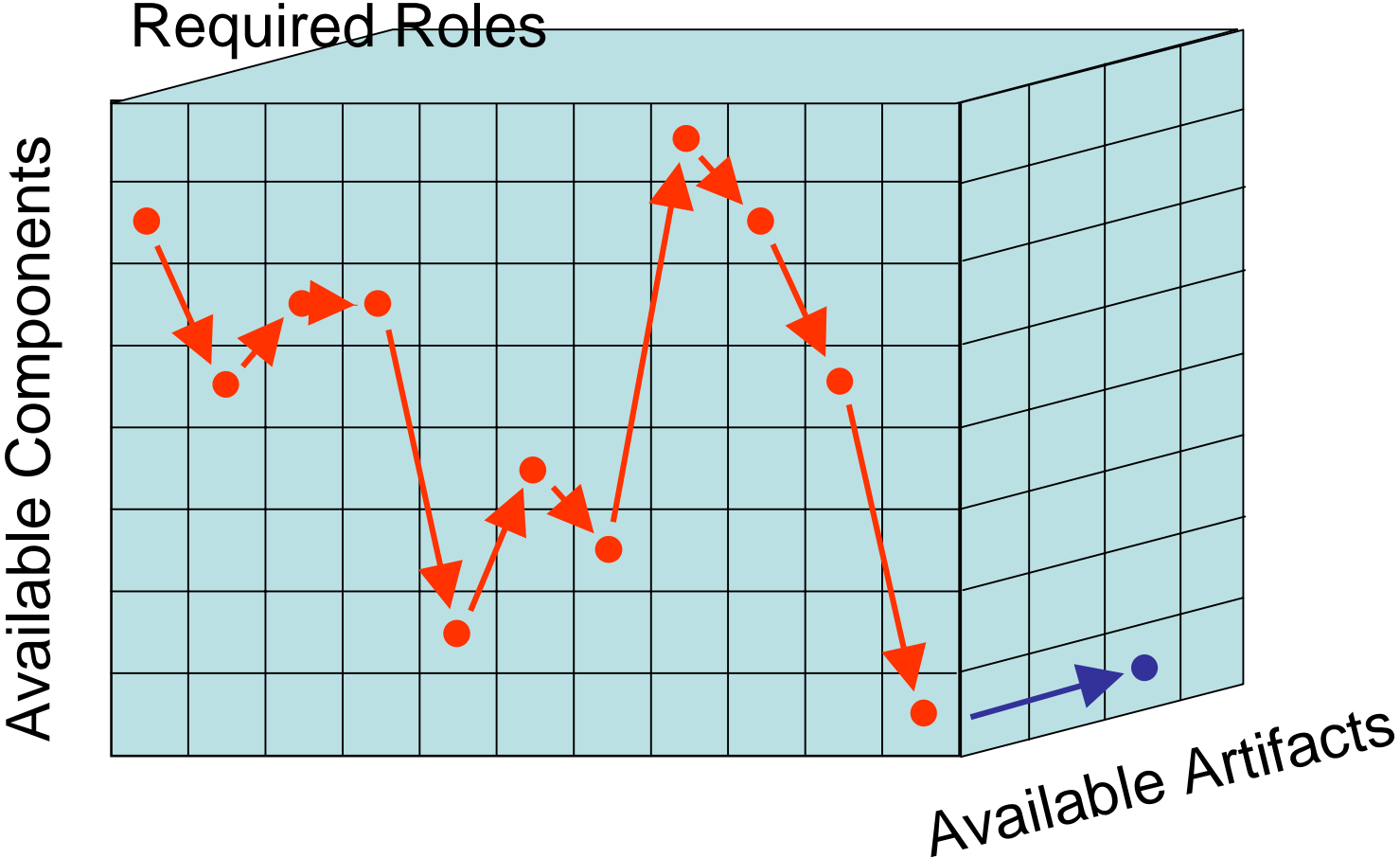

Incremental Deployment

- Deployment plan is populated from the Morphological box for the target
- TargetManager should know the following information
 - Resources
 - Currently available resources
 - What is deployed
- TargetManager calculates the delta between the new deployment plan and the target specific information
- TargetManager only executes the incremental deployment plan

Protocol for Incremental Deployment

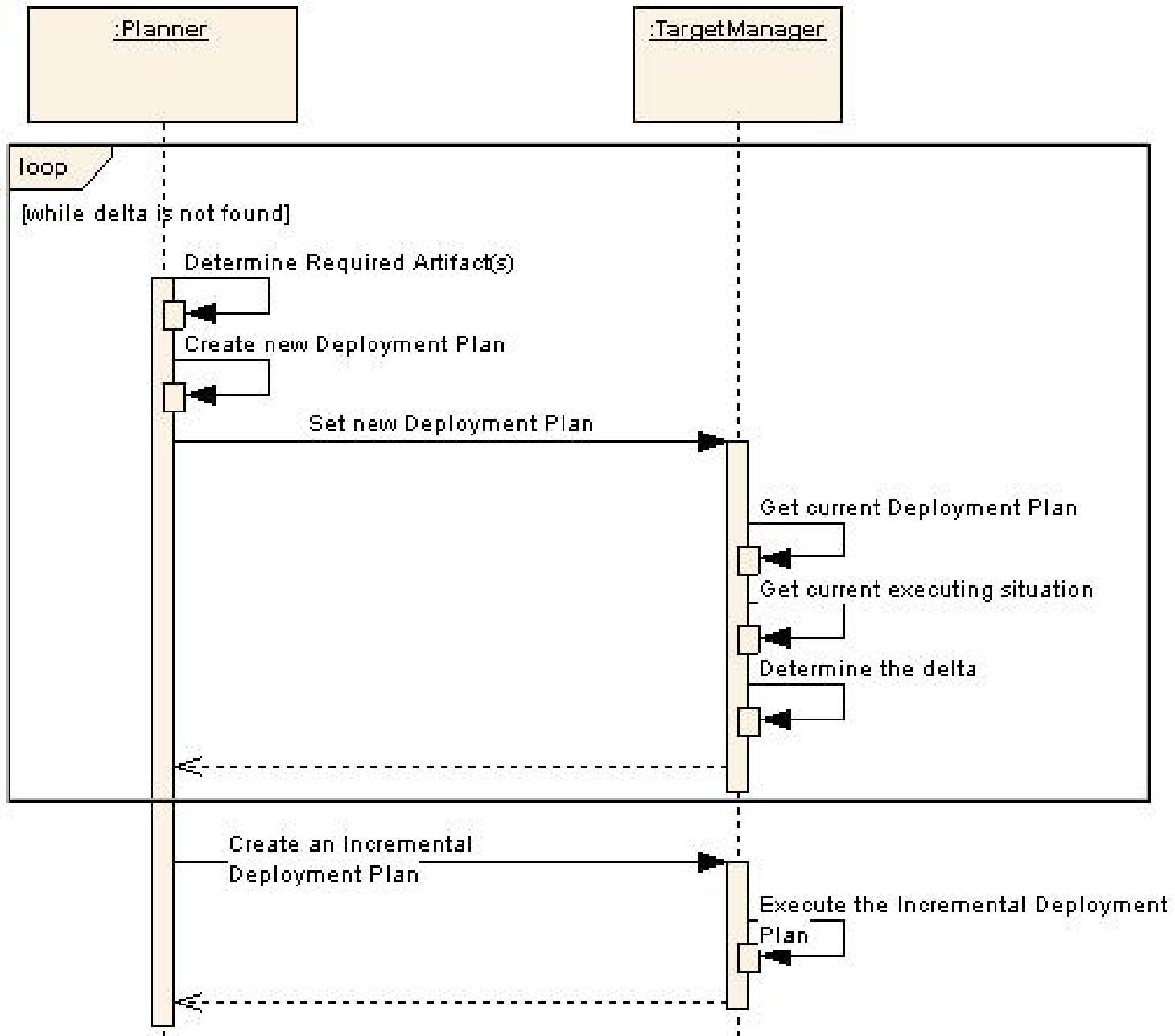

Details & Caveats

- The deployment plan must be executable by the TargetManager
- If not, the loop of the interaction will continue until an executable plan is found
- New configuration should be ready before stopping old one
- Embedded systems not allowed to stop should execute the transition carefully

Proposed Additions to D&C

- Introduction of Role
 - Additional descriptors
- Morphological Search
 - Repository
 - Store the Physical Solution Space in terms of Morphological Box
 - Planner
 - Capability to search the Morphological Box
- Incremental Deployment
 - TargetManager
 - Functionality to calculate delta and execute the Incremental Deployment Plan

Proposed Modification to D&C

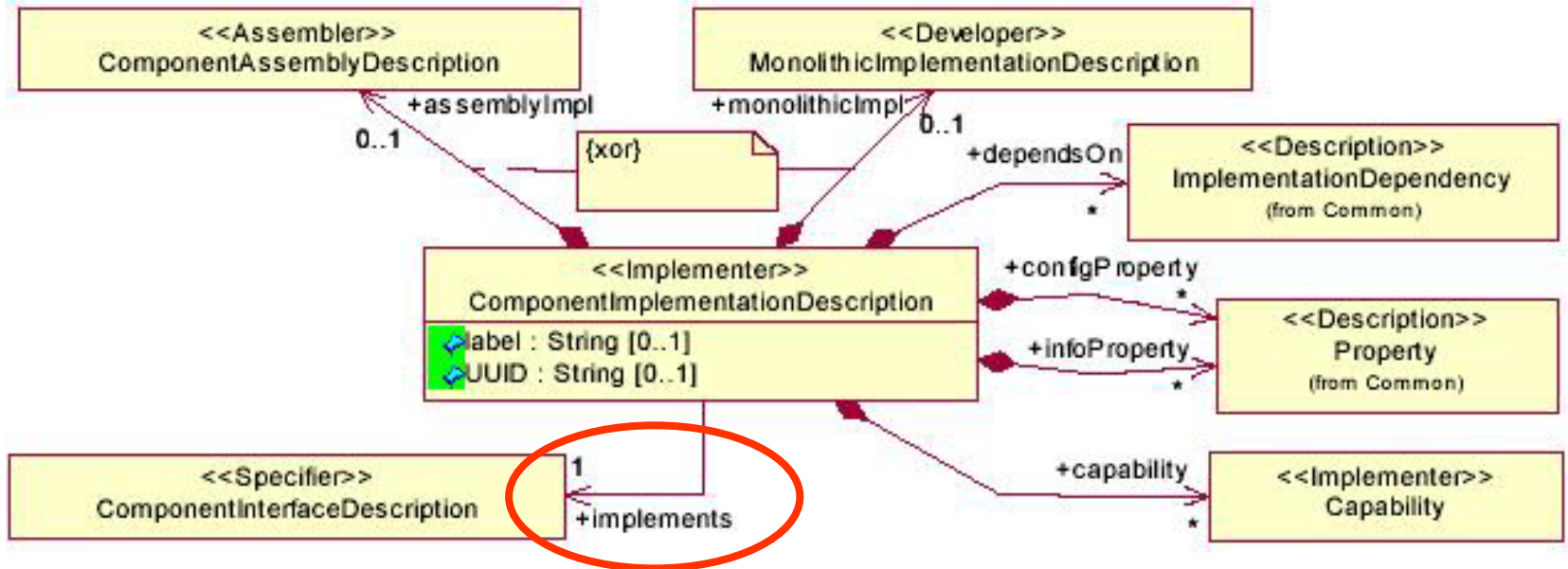

- Association between **ComponentImplementationDescription** with **ComponentInterfaceDescription** is unidirectional
- It must be bidirectional to search the implementation of the component

Summary & Future Works

- Dynamic Reconfiguration Required
 - Ex. Software Defined Radio
- Proposed Additions to Dynamic D&C
 - Role
 - Morphological Approach
 - Incremental Deployment
- Proposed Modification to D&C
 - Bidirectional association between ComponentImplementationDescription with ComponentInterfaceDescription
- Future Works
 - Incorporate these proposals into the D&C specification
 - Ontology-based search techniques may be used in the future development