

GENERAL DYNAMICS

Decision Systems

SUCCESSFULLY INTRODUCING CORBA INTO THE SIGNAL PROCESSING CHAIN OF A SOFTWARE-DEFINED RADIO

Dave Dohse
dave.dohse@gd-decisionssystem.com
(480) 441-2310

GENERAL DYNAMICS
Decision Systems

July 16, 2002 1

Application of CORBA within an SDR

CORBA is the engine for Software-Defined Radio (SDR) Flexibility

- **As demonstrated in development of the Navy's Digital Modular Radio (DMR), CORBA facilitates:**
 - Redeployment of objects to a variety of processing resources including simulation environments
 - Routing of communications from an object to other known objects on any other processing resource
 - Quick creation of applications via modification of high-level application topology scripts to specify a new connectivity for objects
 - this capability enabled creation of a radio simulcast capability within a matter of hours for an Open System Architecture (OSA) evaluation of DMR
 - Real-Time mechanisms for the deterministic operation necessary within an SDR
 - Datapath reconfigurability for loopback, repeating, bridging

GENERAL DYNAMICS
Decision Systems

July 16, 2002 2

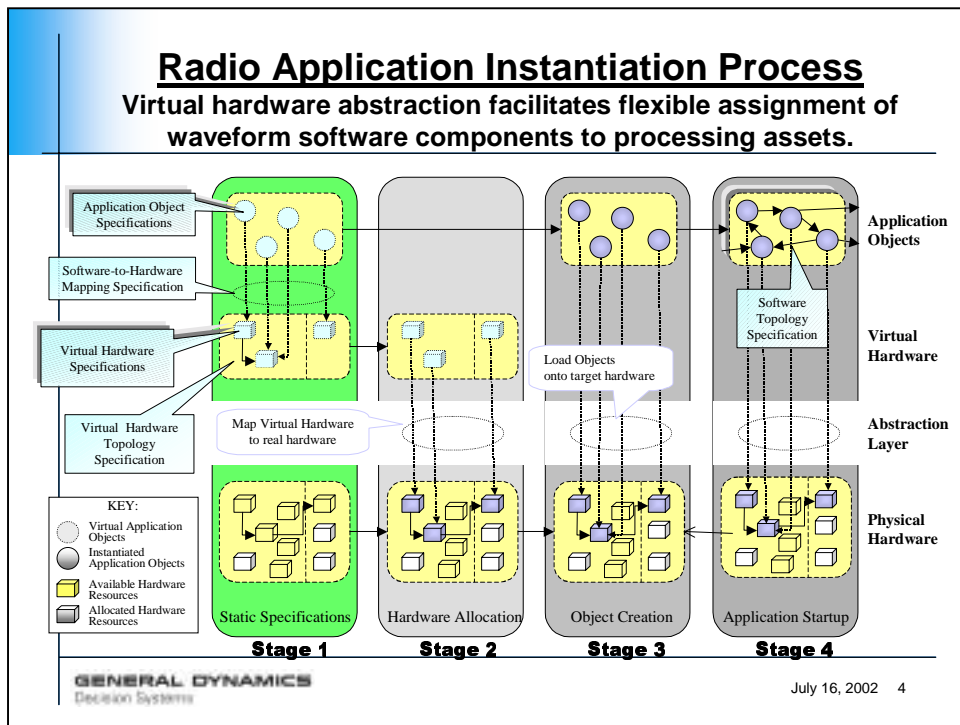
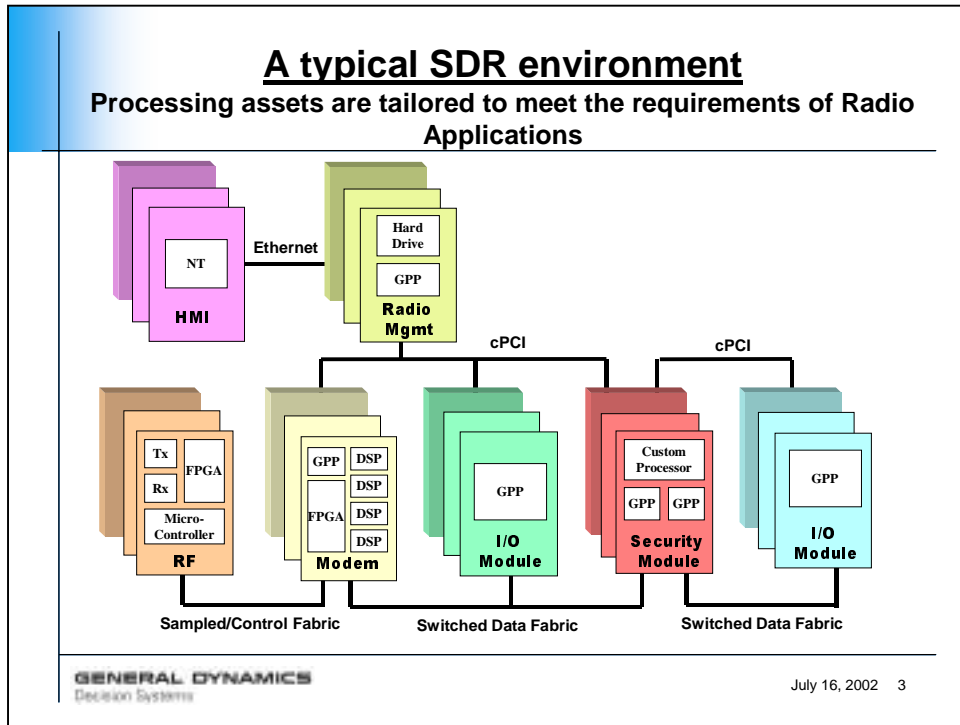

Pluggable Transport Alternatives to TCP/IP

Addressing schemes and aliasing provide a means for dictating client/server transport mechanisms and segregating control/data.

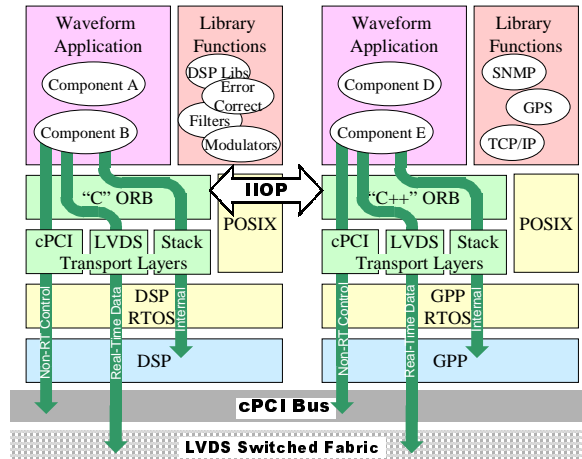

GENERAL DYNAMICS
Decision Systems

July 16, 2002 5

CORBA Real-Time Policy Extensions

Deterministic operation is made possible through time-out and priority mechanisms not available in standard CORBA.

- **Priority Mappings [CORBA 24.12]**
 - Normalizes priority of clients across RTOS's to insure against priority inversion
- **Mutex Interface [CORBA 24.16]**
 - Extends RTOS Mutex protections to CORBA as a means of locking access to CORBA implementations (e.g., memory)
- **Threadpools [CORBA 24.17]**
 - Processing "lanes" (collections of execution threads) providing protection from encroachment by other threadpools
- **PrivateConnectionPolicy [CORBA 24.20]**
 - Allows the establishment of dedicated transport connections
- **Invocation Timeout [CORBA 24.21]**
 - Provides a uniform method of specifying timeouts relative to connection failures and delays prior to attempting renewal of connections



GENERAL DYNAMICS
Decision Systems

July 16, 2002 6

SDR Bridging via CORBA

CORBA enables the dynamic reconfiguration of SDR datapaths necessary for "true" bridging of Radio Applications.

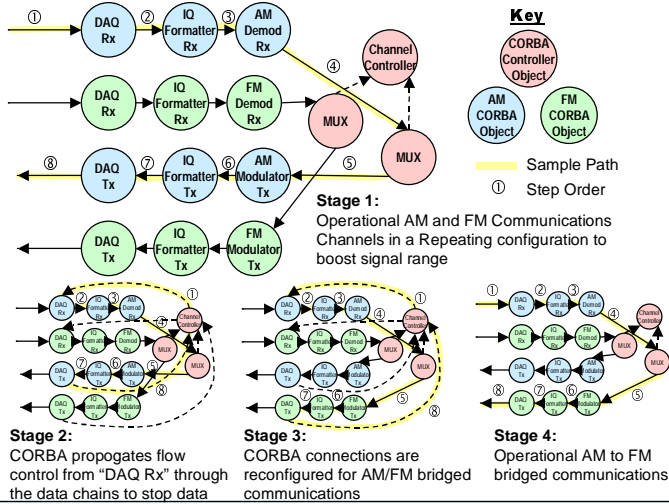

GENERAL DYNAMICS
Decision Systems

July 16, 2002 7

High-performance "C" ORB

Demonstrated superior performance affords the flexibility of CORBA without unnecessary overhead.

- **GD Custom "C" ORB**
 - 40 MHz Sharc DSP, Liberty OS over a cPCI bus
 - ORB is characterized by use of **Custom Transport and Pre-connects** which minimize overhead.
- **Commercial C++ ORB**
 - 266 MHz Pentium GPP over a PC-104 Bus
 - **C++ language** (vs. "C") and Full CORBA spec compliance support for **Dynamic Invocation** introduce greater overhead vs. a Minimum CORBA "C" ORB

Local Call - occurs on the processor stack
Remote Call - involves marshalling & data transmission across bus using transport layer

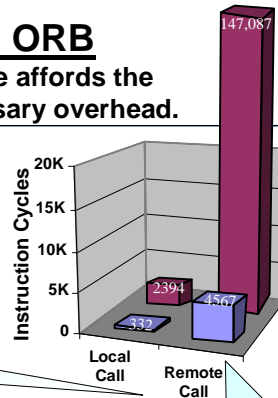

- Key "C" ORB Advantages:**
- **Custom Transport** over cPCI bus using Shared Memory vs. IP
 - **Pre-connects** used to establish persistent transport connections when objects are created.

ORB	Message Type	Bytes	CORBA Latency (µs)	Transport Latency (µs)	Speed (MHz)	Instruction Cycles
GD custom "C" ORB	Local	40	8.3	0	40	332
	Remote	20	60	54	40	4,567
Commercial C++ ORB [†]	Local	256	9	0	266	2,394
	Remote	32	553	471	266	147,087

[†] Source: "CORBA Delays in a Software-Defined Radio" IEEE Communications Magazine, February 2002. Distributed Commercial C++ ORB Remote latency as 46% Transport, 54% ORB per "Real-Time CORBA Trade Study", 1/10/2000 Boeing Corporation Phantom Works, doc. nos. D204-31159-1-5; http://ois.com/technical/rt_dicce/release.html.

GENERAL DYNAMICS
Decision Systems

July 16, 2002 8

CORBA Myths



- **Myth #1: CORBA footprint starves DSPs of critical memory resources**

- Fact: A Minimum CORBA Compliant “C” ORB can be optimized to use only 75KB of external DSP memory
- Fact: Internal DSP memory and remaining external memory is available for user applications – e.g., on a TI C5510 DSP, that leaves all 320KB of internal memory and most of the 8MB of addressable external memory

- **Myth #2: CORBA runtime overhead heavily taxes real-time processing budgets**

- Fact: Taking advantage of alternative transports to TCP/IP and setting up persistent connections for datapath operations removes the bulk of overhead typically attributed to “CORBA”
- Fact: CORBA communications occurring on a 40 MIP DSP processor stack were measured at 8.3 microseconds and over cPCI bus (1.6K Bytes) required 80 microseconds

CORBA Myths (cont'd)



- **Myth #3: CORBA is not appropriate for a non-Object Oriented languages like “C”**

- Fact: It is possible to introduce inheritance mechanisms for “C” via CORBA and provide the user with a level of control over realization of inherited operations (e.g., copies or shared implementations)

- **Myth #4: Flexibility offered by CORBA is unnecessary for an embedded SDR environment**

- Fact: CORBA provides fault tolerant mechanisms which facilitate failover to secondary objects
- Fact: CORBA provides a means of dynamically switching an SDR datapath to bridge communications

Conclusion



- **CORBA provides SDRs with the means for adapting to a wide range of processing assets**
- **Key to the effective use of CORBA in an SDR is the blending of minimum CORBA with optimized Transport layers, Pre-connects and Real-Time processing mechanisms**
- **The Digital Modular Radio (DMR) demonstrates that CORBA can be effectively applied to an SDR**
 - The DMR is currently in limited production,
 - The DMR is successfully executing during independent Navy shipboard Technical Evaluation
 - The DMR SATCOM waveform is nearing successful completion of US Government Joint Interoperability Test Command (JTIC) certification

References

- [1] Irfan Pyarali, Carlos O’Ryan, Douglas Schmidt, Aniruddha Gokhale, Nanbor Wang, and Vishal Kachroo, “Applying Optimization Principle Patterns to Real-time ORBs”, 5th USENIX Conference on OO Technologies and Systems (COOTS ’99), San Diego, CA, May 1999.
- [2] Object Management Group, *The Common Object Request Broker: Architecture and Specification*, Revision 2.4.2, February 2001
- [3] John Bertrand, John W. Cruz, Bryan Majkrzak, Thomas Rossano - ITT Aerospace/Communications, "CORBA Delays in a Software-Defined Radio" IEEE Communications Magazine, February 2002.
- [4] Jeffrey H. Reed, *Software Radio: A Modern Approach to Radio Engineering*, Prentice Hall PTR, 2002.