



Interaction Flow Modeling Language

Version 1.0

OMG Document Number: formal/2015-02-05

Standard Document URL: <http://www.omg.org/spec/IFML/1.0/>

Normative Machine Consumable Files:

<http://www.omg.org/spec/IFML/20140301/IFML-Metamodel.xmi>

<http://www.omg.org/spec/IFML/20140301/IFML-Profile.xmi>

<http://www.omg.org/spec/IFML/20140301/IFML-DI.xmi>

Copyright © 2014 88Solutions
Copyright © 2014 Data Access Technologies, Inc. (Model Driven Solutions)
Copyright © 2014 Fujitsu Limited
Copyright © 2014 Ivar Jacobson International
Copyright © 2015 Object Management Group
Copyright © 2014 Softeam
Copyright © 2014 Thales
Copyright © 2014 WebRatio

USE OF SPECIFICATION - TERMS, CONDITIONS & NOTICES

The material in this document details an Object Management Group specification in accordance with the terms, conditions and notices set forth below. This document does not represent a commitment to implement any portion of this specification in any company's products. The information contained in this document is subject to change without notice.

LICENSES

The companies listed above have granted to the Object Management Group, Inc. (OMG) a nonexclusive, royalty-free, paid up, worldwide license to copy and distribute this document and to modify this document and distribute copies of the modified version. Each of the copyright holders listed above has agreed that no person shall be deemed to have infringed the copyright in the included material of any such copyright holder by reason of having used the specification set forth herein or having conformed any computer software to the specification.

Subject to all of the terms and conditions below, the owners of the copyright in this specification hereby grant you a fully-paid up, non-exclusive, nontransferable, perpetual, worldwide license (without the right to sublicense), to use this specification to create and distribute software and special purpose specifications that are based upon this specification, and to use, copy, and distribute this specification as provided under the Copyright Act; provided that: (1) both the copyright notice identified above and this permission notice appear on any copies of this specification; (2) the use of the specifications is for informational purposes and will not be copied or posted on any network computer or broadcast in any media and will not be otherwise resold or transferred for commercial purposes; and (3) no modifications are made to this specification. This limited permission automatically terminates without notice if you breach any of these terms or conditions. Upon termination, you will destroy immediately any copies of the specifications in your possession or control.

PATENTS

The attention of adopters is directed to the possibility that compliance with or adoption of OMG specifications may require use of an invention covered by patent rights. OMG shall not be responsible for identifying patents for which a license may be required by any OMG specification, or for conducting legal inquiries into the legal validity or scope of those patents that are brought to its attention. OMG specifications are prospective and advisory only. Prospective users are responsible for protecting themselves against liability for infringement of patents.

GENERAL USE RESTRICTIONS

Any unauthorized use of this specification may violate copyright laws, trademark laws, and communications regulations and statutes. This document contains information which is protected by copyright. All Rights Reserved. No part of this work covered by copyright herein may be reproduced or used in any form or by any means--graphic, electronic, or mechanical, including photocopying, recording, taping, or information storage and retrieval systems--without permission of the copyright owner.

DISCLAIMER OF WARRANTY

WHILE THIS PUBLICATION IS BELIEVED TO BE ACCURATE, IT IS PROVIDED "AS IS" AND MAY CONTAIN ERRORS OR MISPRINTS. THE OBJECT MANAGEMENT GROUP AND THE COMPANIES LISTED ABOVE MAKE NO WARRANTY OF ANY KIND, EXPRESS OR IMPLIED, WITH REGARD TO THIS PUBLICATION, INCLUDING BUT NOT LIMITED TO ANY WARRANTY OF TITLE OR OWNERSHIP, IMPLIED WARRANTY OF MERCHANTABILITY OR WARRANTY OF FITNESS FOR A PARTICULAR PURPOSE OR USE. IN NO EVENT SHALL THE OBJECT MANAGEMENT GROUP OR ANY OF THE COMPANIES LISTED ABOVE BE LIABLE FOR ERRORS CONTAINED HEREIN OR FOR DIRECT, INDIRECT, INCIDENTAL, SPECIAL, CONSEQUENTIAL, RELIANCE OR COVER DAMAGES, INCLUDING LOSS OF PROFITS, REVENUE, DATA OR USE, INCURRED BY ANY USER OR ANY THIRD PARTY IN CONNECTION WITH THE FURNISHING, PERFORMANCE, OR USE OF THIS MATERIAL, EVEN IF ADVISED OF THE POSSIBILITY OF SUCH DAMAGES.

The entire risk as to the quality and performance of software developed using this specification is borne by you. This disclaimer of warranty constitutes an essential part of the license granted to you to use this specification.

RESTRICTED RIGHTS LEGEND

Use, duplication or disclosure by the U.S. Government is subject to the restrictions set forth in subparagraph (c) (1) (ii) of The Rights in Technical Data and Computer Software Clause at DFARS 252.227-7013 or in subparagraph (c)(1) and (2) of the Commercial Computer Software - Restricted Rights clauses at 48 C.F.R. 52.227-19 or as specified in 48 C.F.R. 227-7202-2 of the DoD F.A.R. Supplement and its successors, or as specified in 48 C.F.R. 12.212 of the Federal Acquisition Regulations and its successors, as applicable. The specification copyright owners are as indicated above and may be contacted through the Object Management Group, 109 Highland Avenue, Needham, MA 02494, U.S.A.

TRADEMARKS

IMM®, MDA®, Model Driven Architecture®, UML®, UML Cube logo®, OMG Logo®, CORBA® and XMI® are registered trademarks of the Object Management Group, Inc., and Object Management Group™, OMG™, Unified Modeling Language™, Model Driven Architecture Logo™, Model Driven Architecture Diagram™, CORBA logos™, XMI Logo™, CWM™, CWM Logo™, IOP™, MOF™ and OMG Interface Definition Language (IDL)™ are trademarks of the Object Management Group. All other products or company names mentioned are used for identification purposes only, and may be trademarks of their respective owners.

COMPLIANCE

The copyright holders listed above acknowledge that the Object Management Group (acting itself or through its designees) is and shall at all times be the sole entity that may authorize developers, suppliers and sellers of computer software to use certification marks, trademarks or other special designations to indicate compliance with these materials.

Software developed under the terms of this license may claim compliance or conformance with this specification if and only if the software compliance is of a nature fully matching the applicable compliance points as stated in the specification. Software developed only partially matching the applicable compliance points may claim only that the software was based on this specification, but may not claim compliance or conformance with this specification. In the event that testing suites are implemented or approved by Object Management Group, Inc., software developed using this specification may claim compliance or conformance with the specification only if the software satisfactorily completes the testing suites.

OMG'S ISSUE REPORTING PROCEDURE

All OMG specifications are subject to continuous review and improvement. As part of this process we encourage readers to report any ambiguities, inconsistencies, or inaccuracies they may find by completing the Issue Reporting Form listed on the main web page <http://www.omg.org>, under Documents, Report a Bug/Issue (http://www.omg.org/report_issue.htm).

Table of Contents

Preface	v
1 Scope	1
2 Conformance	1
3 Normative References	1
4 Terms and Definitions	2
5 Symbols	2
6 Additional Information	2
6.1 Business Motivation	2
6.2 Design Principles	3
6.3 IFML Artifacts	3
6.4 Acknowledgments	3
7 IFML Specification	5
7.1 Key Concepts of IFML	5
7.2 IFML in a Nutshell	6
7.3 Extensibility	10
7.4 Concept List	11
8 IFML Metamodel	17
8.1 High-Level Description	17
8.1.1 IFML Model	18
8.1.2 Interaction Flow Model	19
8.1.3 Interaction Flow Elements	20
8.1.4 View Elements	21
8.1.5 Parameters	23
8.1.6 Events	24
8.1.7 Expressions	25
8.1.8 Content Binding	26
8.1.9 Context	27
8.1.10 Specific ViewComponents	28
8.1.11 Modularization	29
8.2 Package DataTypes	30

8.2.1 Enumeration Direction	30
8.2.2 Enumeration ContextVariableScope Description.....	30
8.2.3 Enumeration SystemEventType	30
8.3 Package Core	31
8.3.1 Class Action	31
8.3.2 Class ActionEvent	31
8.3.3 Class ActivationExpression	31
8.3.4 Class ActivityConcept	32
8.3.5 Class Annotation	32
8.3.6 Class BehaviorConcept	32
8.3.7 Class BehavioralFeatureConcept	33
8.3.8 Class BooleanExpression	33
8.3.9 Class BPMNActivityConcept	33
8.3.10 Class CatchingEvent	33
8.3.11 Class ConditionalExpression	34
8.3.12 Class Constraint	34
8.3.13 Class ContentBinding	34
8.3.14 Class Context	35
8.3.15 Class ContextDimension	35
8.3.16 Class ContextVariable	35
8.3.17 Class DataBinding	36
8.3.18 Class DataContextVariable	36
8.3.19 Class DataFlow	36
8.3.20 Class DomainConcept	37
8.3.21 Class DomainElement	37
8.3.22 Class DomainModel	37
8.3.23 Class DynamicBehavior	38
8.3.24 Class Element	38
8.3.25 Class Event	38
8.3.26 Class Expression	39
8.3.27 Class FeatureConcept	39
8.3.28 Class IFMLModel	39
8.3.29 Class InteractionFlow	40
8.3.30 Class InteractionFlowElement	40
8.3.31 Class InteractionFlowExpression.....	41
8.3.32 Class InteractionFlowModel	41
8.3.33 Class InteractionFlowModelElement	41
8.3.34 Class ModularizationElement	42
8.3.35 Class Module	42
8.3.36 Class ModuleDefinition	43
8.3.37 Class ModulePackage.....	43
8.3.38 Class NamedElement	44
8.3.39 Class NavigationFlow	44
8.3.40 Class Parameter	44
8.3.41 Class ParameterBinding	45
8.3.42 Class ParameterBindingGroup	45
8.3.43 Class Port	46
8.3.44 Class PortDefinition	46
8.3.45 Class SimpleContextVariable	46
8.3.46 Class SystemEvent	47

8.3.47 Class ThrowingEvent	47
8.3.48 Class UMLBehavior	47
8.3.49 Class UMLBehavioralFeature	48
8.3.50 Class UMLStructuralFeature	48
8.3.51 Class UMLDomainConcept	48
8.3.52 Class ViewComponent	49
8.3.53 Class ViewComponentPart	49
8.3.54 Class ViewContainer	49
8.3.55 Class ViewElement	50
8.3.56 Class ViewElementEvent	51
8.3.57 Class Viewpoint	51
8.3.58 Class VisualizationAttribute	51
8.4 Package Extensions	52
8.4.1 Class Details	52
8.4.2 Class Device	52
8.4.3 Class Field	52
8.4.4 Class Form	53
8.4.5 Class List	53
8.4.6 Class LandingEvent	53
8.4.7 Class JumpEvent	54
8.4.8 Class Menu	54
8.4.9 Class OnLoadEvent	54
8.4.10 Class OnSelectEvent	54
8.4.11 Class OnSubmitEvent	55
8.4.12 Class Position	55
8.4.13 Class SelectionField	55
8.4.14 Class SetContextEvent	55
8.4.15 Class SimpleField	56
8.4.16 Class Slot	56
8.4.17 Class UserRole	56
8.4.18 Class ValidationRule	57
8.4.19 Class Window	57
9 IFML Execution Semantics	59
9.1 Introduction	59
9.2 Relevant Aspects for IFML Execution Semantics	59
9.2.1 Triggering Events	59
9.2.2 Parameter Propagation	59
9.2.3 Navigation History Preservation	60
9.3 ViewComponent Computation Process	60
10 IFML Diagram Definition	63
10.1 Introduction	63
10.2 Conformance Criteria	63
10.3 Architecture	63

10.4 IFML Diagram Interchange (DI) Meta-model	65
10.5 Package IFMLDI	66
10.5.1 Enumeration LabelKind	66
10.5.2 Class IFMLCompartment	67
10.5.3 Class IFMLConnection	67
10.5.4 Class IFMLDiagram	68
10.5.5 Class IFMLDiagramElement	68
10.5.6 Class IFMLLabel	69
10.5.7 Class IFMLNode	69
10.5.8 Class IFMLStyle	69
10.6 IFML DI to DG Mapping Specification	70
11 UML Profile for IFML	75
11.1 Overview	75
11.2 The IFML Profile of UML	75
11.3 Using IFML Stereotypes	86
11.4 Profile Metamodel Mapping	88
Annex A - IFML by Example: Modeling an Email	91
Annex B - IFML by Example: Modeling an Online Bookstore	113
Annex C - Mapping to the Windows Presentation Framework	125
Annex D - Mapping to Java Swing	129
Annex E - Mapping to HTML	131

Preface

About the Object Management Group

OMG

Founded in 1989, the Object Management Group, Inc. (OMG) is an open membership, not-for-profit computer industry standards consortium that produces and maintains computer industry specifications for interoperable, portable and reusable enterprise applications in distributed, heterogeneous environments. Membership includes Information Technology vendors, end users, government agencies and academia.

OMG member companies write, adopt, and maintain its specifications following a mature, open process. OMG's specifications implement the Model Driven Architecture® (MDA®), maximizing ROI through a full-lifecycle approach to enterprise integration that covers multiple operating systems, programming languages, middleware and networking infrastructures, and software development environments. OMG's specifications include: UML® (Unified Modeling Language™); CORBA® (Common Object Request Broker Architecture); CWM™ (Common Warehouse Metamodel); and industry-specific standards for dozens of vertical markets.

More information on the OMG is available at <http://www.omg.org/>.

OMG Specifications

As noted, OMG specifications address middleware, modeling and vertical domain frameworks. All OMG Formal Specifications are available from this URL:

<http://www.omg.org/spec>

Specifications are organized by the following categories:

Business Modeling Specifications

Middleware Specifications

- **CORBA/IIOP**
- **Data Distribution Services**
- **Specialized CORBA**

IDL/Language Mapping Specifications

Modeling and Metadata Specifications

- **UML, MOF, CWM, XMI**
- **UML Profile**

Modernization Specifications

Platform Independent Model (PIM), Platform Specific Model (PSM), Interface Specifications

- **CORBAServices**
- **CORBAFacilities**

CORBA Embedded Intelligence Specifications

CORBA Security Specifications

OMG Domain Specifications

Signal and Image Processing Specifications

All of OMG's formal specifications may be downloaded without charge from our website. (Products implementing OMG specifications are available from individual suppliers.) Copies of specifications, available in PostScript and PDF format, may be obtained from the Specifications Catalog cited above or by contacting the Object Management Group, Inc. at:

OMG Headquarters
109 Highland Avenue
Needham, MA 02494
USA
Tel: +1-781-444-0404
Fax: +1-781-444-0320
Email: pubs@omg.org

Certain OMG specifications are also available as ISO standards. Please consult <http://www.iso.org>

Issues

The reader is encouraged to report any technical or editing issues/problems with this specification to http://www.omg.org/report_issue.htm.

1 Scope

This specification defines the Interaction Flow Modeling Language (IFML). The objective of IFML is to provide system architects, software engineers, and software developers with tools for the definition of Interaction Flow Models that describe the principal dimensions of an application front-end: the view part of the application, made of view containers and view components; the objects that embody the state of the application, and the references to business logic actions that can be executed; the binding of view components to data objects and events; the control logic that determines the actions to be executed after an event occurrence; and the distribution of control, data, and business logic at the different tiers of the architecture.

2 Conformance

There are five ways in which a tool may demonstrate conformance to the IFML metamodel.

1. *Abstract syntax conformance.* A tool demonstrating abstract syntax conformance provides a user interface and/or API that enables instances of concrete IFML metaclasses to be created, read, updated, and deleted. The tool must also provide a way to validate the well-formedness of models that corresponds to the constraints defined in the IFML metamodel.
2. *Concrete syntax conformance.* A tool demonstrating concrete syntax conformance provides a user interface and/or API that enables instances of IFML notation to be created, read, updated, and deleted.
3. *Model interchange conformance.* A tool demonstrating model interchange conformance can import and export conformant XMI for all valid IFML models. Model interchange conformance implies abstract syntax conformance.
4. *Diagram interchange conformance.* A tool demonstrating diagram interchange conformance can import and export conformant DI for all valid IFML models with diagrams. Diagram interchange conformance implies both concrete syntax conformance and abstract syntax conformance.
5. *Semantic conformance.* A tool demonstrating semantic conformance provides a demonstrable way to interpret IFML semantics, e.g., code generation, model execution, or semantic model analysis.

A tool can claim conformance with the IFML metamodel if and only if the software fully implements the IFML metamodel in one or more of the above ways. A tool that only partially implements the metamodel can claim only that it is based on this specification, but cannot claim conformance with the specification.

A tool already conforming to the UML specification may demonstrate conformance with the UML Profile for IFML by providing the means to apply the profile to a UML model, as specified in Clause 11.

3 Normative References

The following normative documents contain provisions which, through reference in this text, constitute provisions of this specification. For dated references, subsequent amendments to, or revisions of, any of these publications do not apply.

- S. Bradner, *Key words for use in RFCs to Indicate Requirement Levels*, RFC2119, <http://ietf.org/rfc/rfc2119>, March 1997

- *OMG Unified Modeling Language (OMG UML), Infrastructure, Version 2.4.1, formal/2011-08-05, August 2011.*
- *OMG Unified Modeling Language (OMG UML), Infrastructure, Version 2.4.1, formal/2011-08-06, August 2011.*
- *OMG Meta Object Facility (MOF) Core Specification, Version 2.4.1, formal/2011-08-07, August 2011*
- *OMG MOF 2 XMI Mapping Specification, Version 2.4.1, formal/2011-08-09, August 2011*
- *Diagram Definition (DD), Version 1.0, formal/2012-07-01, July 2012*

4 Terms and Definitions

There are no formal definitions of terms in this specification.

5 Symbols

There are no symbols defined in this specification.

6 Additional Information

6.1 Business Motivation

In the last twenty years, capabilities such as form-based interaction, information browsing, link navigation, multimedia content fruition, and interface personalization have become mainstream in many business-to-consumer (B2C), business-to-business (B2B), and business-to-employee (B2E) applications. These are implemented on top of a variety of technologies and platforms: desktop applications, client-server applications, web applications, rich internet applications, mobile applications, and even human machine interfaces for industrial control, where more and more embedded systems are equipped with browser-based GUIs. This convergence in technologies is reflected in the HTML 5 initiative, which aims at establishing a unified set of concepts and a common technological platform for the development of a broad spectrum of interaction front-ends.

However, the emergence of such an unprecedented range of devices, technological platforms, and communication channels is not accompanied by the advent of an adequate approach for creating a Platform Independent Model (PIM) that can be used to express the interaction design decisions independently of the implementation platform. This causes front-end development to be a costly and inefficient process, where manual coding is the predominant development approach, reuse of design artifacts is low, and portability of applications across platforms remains difficult.

Using IFML for PIM-level interaction flow modeling, brings several benefits to the development process of application front-ends:

- It permits the formal specification of the different perspectives of the front-end: content, interface composition, interaction and navigation options, and connection with the business logic and the presentation.
- It separates the stakeholder concerns by isolating the specification of the front-end from its implementation-specific issues.

- It improves the development process, by fostering the separation of concerns in the user interaction design, thus granting the maximum efficiency to all the different developer roles.
- It enables the communication of interface and interaction design to non-technical stakeholders, permitting validation of requirements from subject matter experts (SMEs) and clients sooner in the development process.

6.2 Design Principles

Front-end design is a complex and multidisciplinary task, where many perspectives intersect. Therefore, IFML is particularly attentive to model usability and understandability, by explicitly addressing all the factors that contribute to making a PIM quickly learned, easy to use, and open to extensibility:

- It is concise, avoiding redundancy and reducing the number of diagram types and concepts needed to express the salient interface and interaction design decisions.
- It includes extensibility in the definition of new concepts (e.g., novel interface components or event types).
- It ensures implementability, that is, it supports the construction of model transformation frameworks and code generators that can map the PIM into a suitable PSM and ultimately into executable applications for a wide range of technological platforms and access devices.
- It ensures model-level reuse, that is, it supports the definition of reusable design patterns that can be stored, documented, searched and retrieved, and re-used in other applications.
- It allows the application of inference rules at the modeling level that automatically apply default modeling patterns and details whenever they can be determined from the context, giving the possibility to avoid the need for modelers to specify inferable information (e.g., automatic inference of the parameters that need to be passed from a component to another at the modeling level).

6.3 IFML Artifacts

The IFML specification consists of four main technical artifacts:

1. *The IFML metamodel* specifies the structure and semantics of the IFML constructs using MOF.
2. *The IFML UML profile* defines a UML-based syntax for expressing IFML models. In particular, the UML profile extends concepts of the following UML diagrams: class diagrams, state machine, and composite structure diagrams.
3. *The IFML visual syntax* offers a dedicated visual syntax for expressing IFML models in a particularly concise way. Specifically, it provides a unique diagram capable of compacting the aspects of the user interface that are otherwise expressed separately with UML class diagrams, state machine, and composite structure diagrams.
4. *The IFML XMI* provides the IFML model exchange format, for tool portability.

6.4 Acknowledgments

The standardization initiative and the FTF of IFML have been lead by Marco Brambilla.

This specification was originally authored by:

- Marco Brambilla (WebRatio and Politecnico di Milano)
- Piero Fraternali (WebRatio and Politecnico di Milano)

Other authors that contributed to the current version include:

- Aldo Bongio (WebRatio)
- Stefano Butti (WebRatio)
- Adriano Comai (Soluta.net and WebRatio)
- Wolfgang Kling (Ecole des Mines de Nantes and WebRatio)
- Manfred R. Koethe (88Solutions)
- Andrea Mauri (WebRatio and Politecnico di Milano)
- Emanuele Molteni (WebRatio)
- Ed Seidewitz (Model Driven Solutions and Ivar Jacobson International)

We wish to thank all the other contributors that provided useful input, feedback, and discussions on the IFML specification.

7 IFML Specification

7.1 Key Concepts of IFML

The Interaction Flow Modeling Language (IFML) supports the platform independent description of graphical user interfaces for applications accessed or deployed on such systems as desktop computers, laptop computers, PDAs, mobile phones, and tablets. The focus of the description is on the structure and behavior of the application as perceived by the end user. The description of the structure and behavior of the business and data components of the application is limited to those aspects that have a direct influence on the user's experience.

With respect to the popular Model-View-Controller (MVC) model of an interactive application,¹ the focus of IFML is on the view part. Furthermore, IFML describes how the view references or is depended on by the model and control parts of the application. In particular:

- With respect to the view, IFML deals with the view composition and the description of the elements that it exposes to the user for interaction.
- With respect to the controller, IFML lets the designer specify the effects of user interactions and system events on the application by defining the relevant events that the controller must take care of.
- With respect to the model, IFML allows for specification of the references to the data objects that embody the state of the application and are published in the user interface, as well as of the reference to the actions that are triggered by the interaction of the user.

IFML can be complemented with external models for the complete specification of applications with aspects that are not directly connected with the user interface and interaction:

- The internal functioning of the actions triggered by the user's interaction can be described using any action model. For example, if the action refers to the invocation of an object's method, this can be described using UML class and collaboration diagrams; if the action refers to the invocation of a web service, this can be described using a SoaML diagram.²
- The object model underlying the application can be described with any structural diagram, for example with a UML class diagram or a Common Warehouse Metamodel (CWM) diagram³.

Modeling the user interface and interaction with IFML amounts to addressing the following aspects:

- The composition of the view, in terms of its partition into independent⁴ visualization units, which can be displayed simultaneously or in mutual exclusion, and can be nested hierarchically.
- The content of the view, in terms of both the data elements published from the application to the user and of the data elements input from the user to the application.
- The commands enabling the user's interaction and the corresponding events.
- The reference to actions triggered by the user's commands.

1. See, for example, <http://en.wikipedia.org/wiki/Mode-view-controller>.

2. See <http://www.omg.org/spec/SoaML>.

3. See <http://www.omg.org/spec/SoaML>.

4. See <http://www.omg.org/cwm/>

- The effects of the user's interaction and of the action execution on the state of the user interface.
- The parameter binding between the elements of the user interface and the triggered actions.

Consequently, an IFML model supports the following design perspectives:

- The *view structure specification*, which consists of the definition of view containers, their nesting relationships, their visibility, and their reachability.
- The *view content specification*, which consists of the definition of view components, i.e., content and data entry elements contained within view containers.
- The *events specification*, which consists of the definition of events that may affect the state of the user interface. Events can be produced by the user's interaction, by the application, or by an external system.
- The *event transition specification*, which consists of the definition of the effect of an event on the user interface. The effect can be the change of the view container or of the content displayed, the triggering of an action, or both.
- The *parameter binding specification*, which consists of the definition of the input-output dependencies between view components and between view components and actions.

7.2 IFML in a Nutshell

Internet application (RIA) can be modeled as having one top-level container, the main window; instead, a Web application can be modeled as having multiple top-containers, one for every dynamic page template.

Each view container can be internally structured in a *hierarchy of sub-containers*. For example, in a desktop or RIA application, the main window can contain multiple tabbed frames, which in turn may contain several nested panes. The child view containers nested within a parent view container can be displayed simultaneously (e.g., an object pane and a property pane) or in *mutual exclusion* (e.g., two alternative tabs). In case of mutually exclusive (XOR) containers one could be the *default container*, displayed by default when the parent container is accessed.

A view container can contain *view components*, which denote the publication of content or interface elements for data entry (e.g., input forms). A view component can have *input and output parameters*. For example, a view component for showing the properties of an object can have as an input parameter the identifier of the object to display; a data entry form or a list of items can have as output parameters the values input or the item selected by the user.

A view container and a view component can be associated with *events*, to denote that they support the user's interaction. For example, a view component can represent: a list associated with an event for selecting one or more items, a form associated with an event for input submission, or an image gallery associated with an event for scrolling through the gallery. Events in concrete are rendered as interactors, which depend on the specific platform and therefore are not modeled in IFML but produced by the PIM to Platform-Specific Model (PSM) transformation rules. For example, the scrolling of an image gallery may be implemented as a link in an HTML application and as a flip gesture in a mobile phone application.

The effect of an event is represented by an *interaction flow* connection, which connects the event to the view container or component affected by the event. For example, in an HTML web application the event caused by the selection of one item from a list may cause the display of a new page with the details of the selected object. This may be represented by an interaction flow connecting the event associated with the list component in a top-level view container (the web page) with the view component representing the object detail, positioned in a different view container (the target web page). The interaction flow expresses a change of state of the user interface: the occurrence of the event causes a transition of state that produces a change in the user interface.

An event can also cause the *triggering of an action*, which is executed prior to updating the state of the user interface; for example, in a web content management application the user can select from a list the elements to delete; the selection event triggers a delete action, after which the page with the list is redisplayed. The effect of an event triggering an action is represented by an interaction flow that connects the action to the view container or component affected by the event.

An *input-output dependency* between view elements (view containers and view components) or between view elements and actions is denoted by *parameter bindings* associated with navigation flows (interaction flows for navigating between view elements). For example, in Figure 7.1, the navigation flow that goes from the event denoting the selection of an item of the Artist Index view component to the Artist view component (showing the selection details), has a parameter binding that associates an output parameter of the Artists Index view component with an input parameter of the Artist view component. See also further examples in Figure 7.2, Figure 7.3, and Figure 7.4.

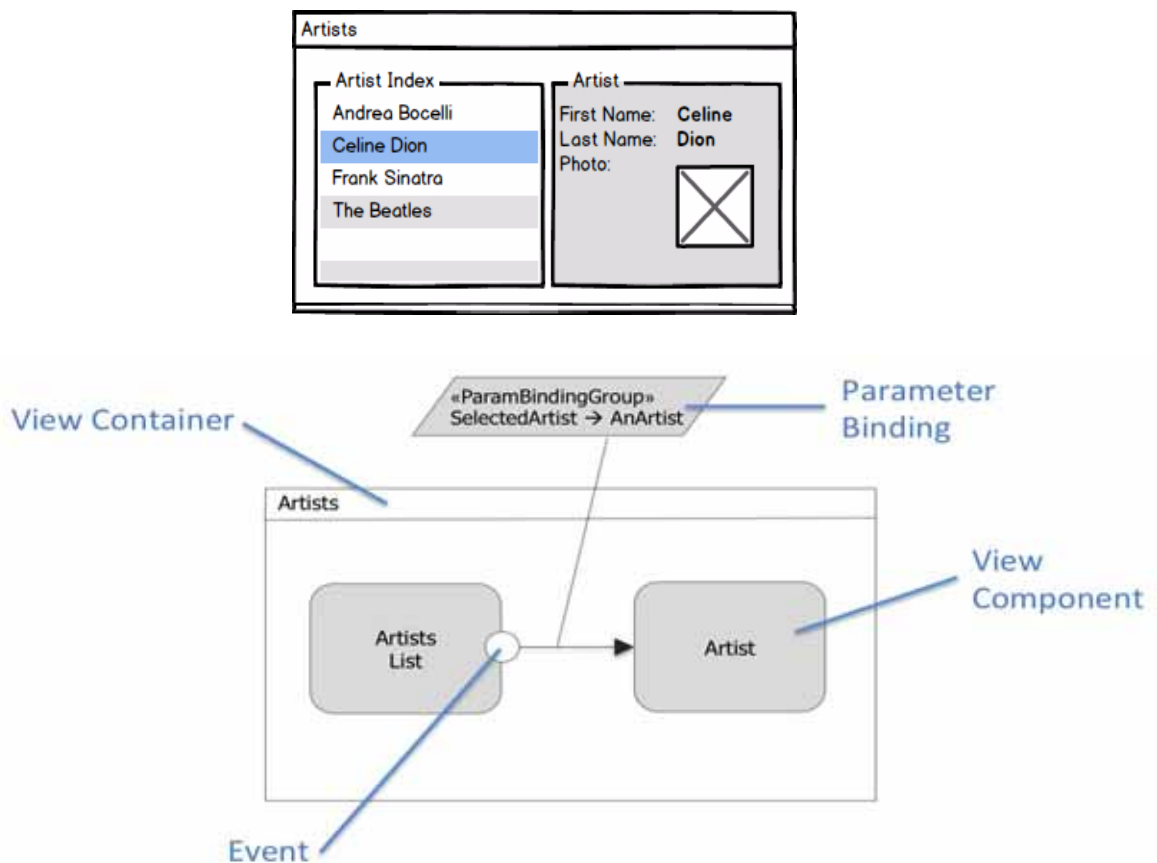

Figure 7.1 - Example of user interface (top) and corresponding IFML model (bottom). The user selects an item in the list and displays its details in the same view container.

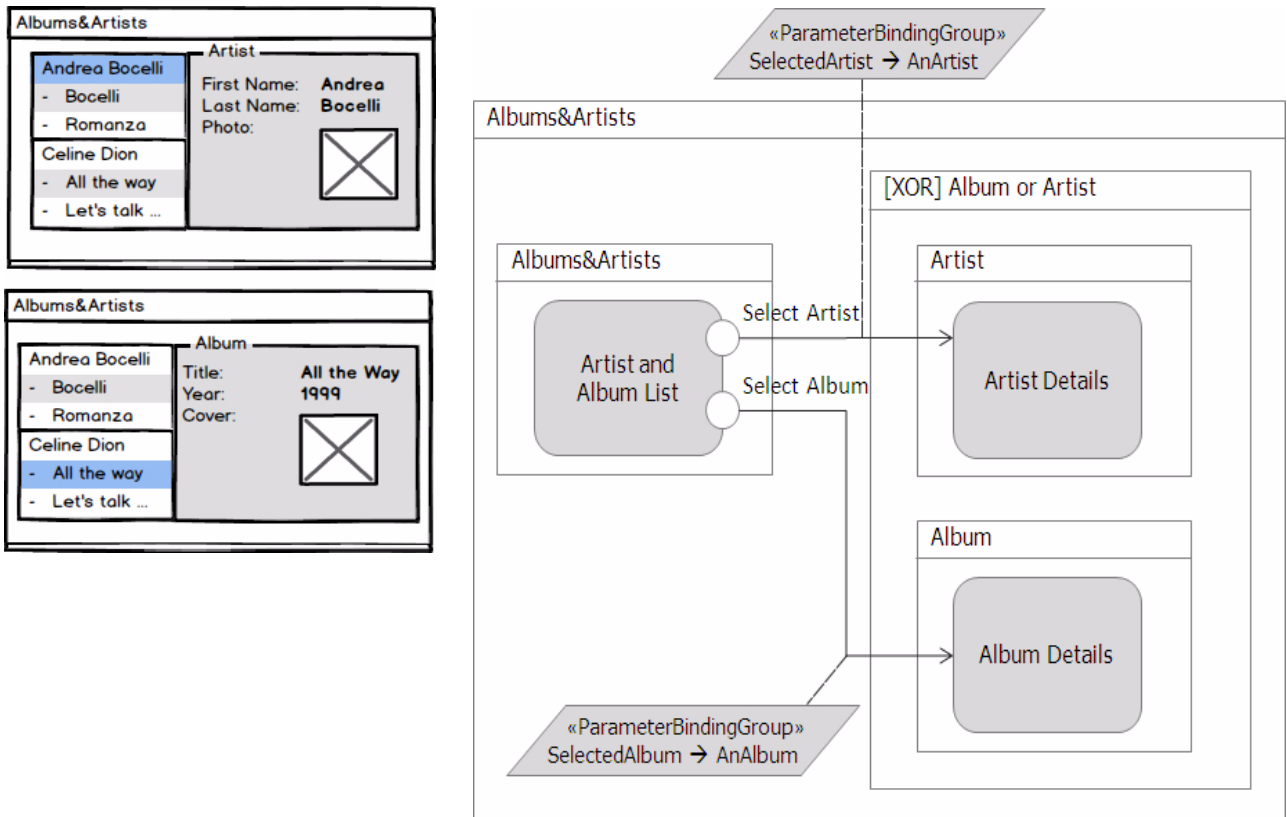

Figure 7.2 - Example of user interface (left) and corresponding IFML model (right). One top-level container comprises three view containers: one with a list of artists and of their albums, one with the details of an artist, and one with the details of an album. The latter two view containers are mutually exclusive: only one at a time is displayed.

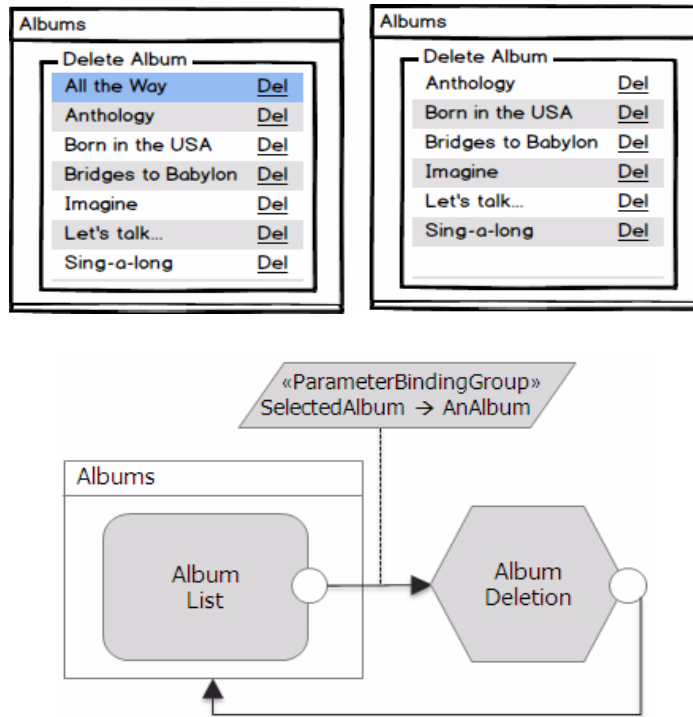

Figure 7.3 - Example of user interface supporting action invocation (top) and corresponding IFML model (bottom). The user can select an item from a list of objects; the selection causes a delete action to be triggered after which the updated list of objects is redisplayed.

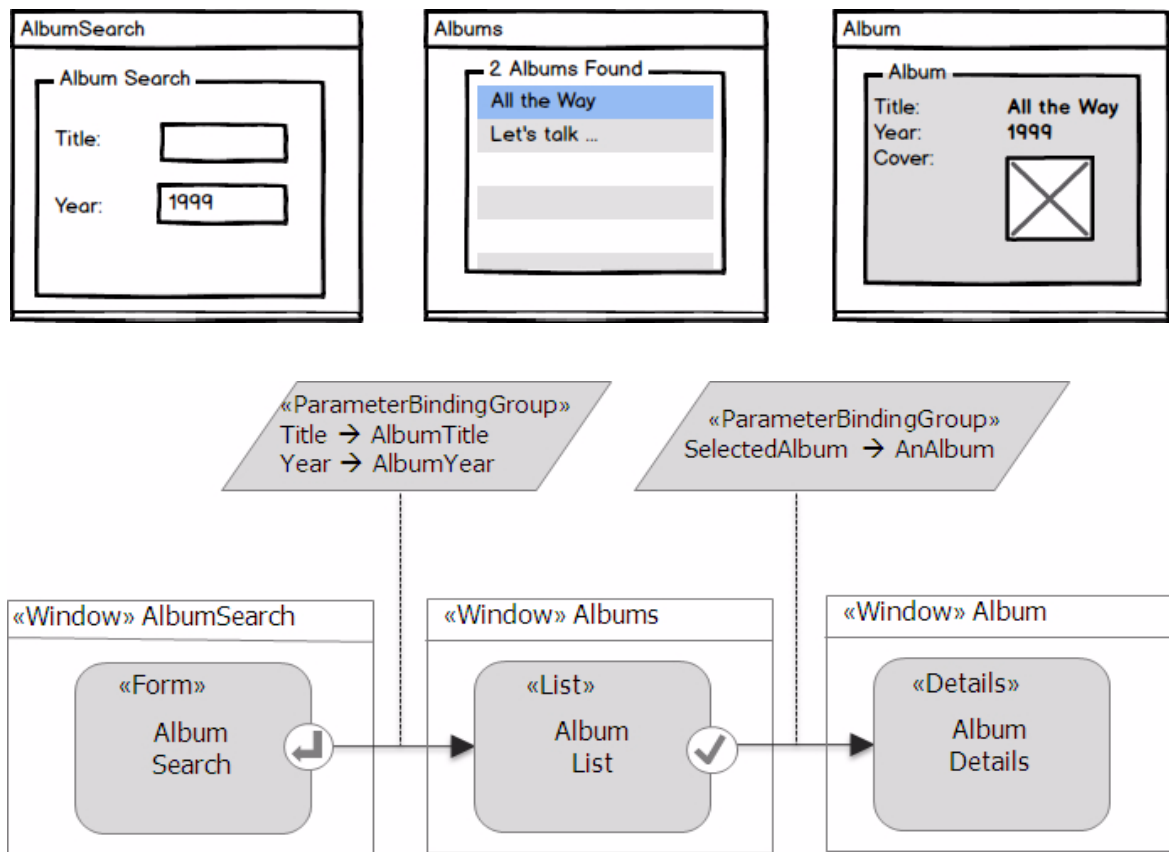

Figure 7.4 - Example of user interface (top) and corresponding IFML model (bottom). The user enters data into an input form and submits them; this event causes a distinct view container to appear with a list of matching objects; finally, the selection of an item in the list causes the display of the corresponding details in a third view container.

7.3 Extensibility

IFML uses the extensibility mechanisms of UML to allow the definition of stereotypes, tagged values, and constraints. The Extensions package exemplifies how the extension mechanism works: it contains concepts that extend concepts from the Core package. In the same way, new packages may be introduced containing new constructs, to model platform-independent or platform-specific concepts.

Extensions are meant to refine the semantics of the core concepts or to provide specific cases of core concepts. As such, they must therefore refine the semantics of the IFML concepts, and not modify it. The following concepts (and their extensions) can be extended in IFML while still achieving compliance to the standard:

- ViewContainer
- ViewComponent
- ViewComponentPart
- Event

- DomainConcept and FeatureConcept
- BehaviorConcept and BehavioralFeatureConcept

Extensions of other elements are not allowed.

7.4 Concept List

Table 7.1 lists the core concepts of IFML and Table 7.2 lists a set of extension concepts provided as an example for the IFML extension mechanism.

Table 7.1 - Essential IFML Concepts

Concept	Meaning	IFML Notation	Example at Implementation level
View Container	An element of the interface that comprises elements displaying content and supporting interaction and/or other ViewContainers.		Web page Window Pane
XOR View Container	A ViewContainer comprising child ViewContainers that are displayed alternatively.		Tabbed panes in Java Frames in HTML
Landmark View Container	A ViewContainer that is reachable from any other element of the user interface without having explicit incoming InteractionFlows.		A logout link in HTML sites that is visible in every page.
Default View Container	A ViewContainer that will be presented by default to the user, when its enclosing container is accessed.		A welcome page

Table 7.1 - Essential IFML Concepts



Concept	Meaning	IFML Notation	Example at Implementation level
View Component	An element of the interface that displays content or accepts input.		An HTML list. A JavaScript image gallery. An input form.
Event	An occurrence that affects the state of the application.		
Action	A piece of business logic triggered by an event; it can be server side (the default) or client-side, denoted as [Client].		A database update. The sending of an email. The spell checking of a text.
Navigation Flow	Update of the interface elements in view or triggering of an action caused by the occurrence of an event. Data may be associated with the flow through parameter bindings.		Sending and receiving of parameters in the HTTP request.
Data Flow	Data passing between ViewComponents or Action as consequence of a previous user interaction.		
Parameter	A typed and named value	Optionally shown. If necessary can be denoted as follows: 	HTTP query string parameters HTTP post parameters JavaScript variables and function parameters
Parameter Binding	Specification that an input parameter of a source is associated with an output parameter of a target.		

Table 7.1 - Essential IFML Concepts

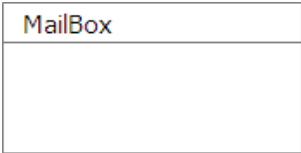
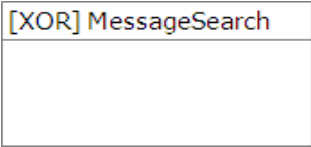
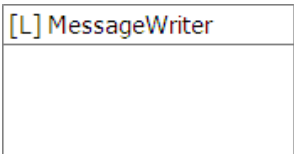
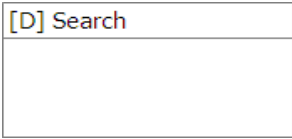

Concept	Meaning	IFML Notation	Example at Implementation level
Parameter Binding Group	Set of ParameterBindings associated to an InteractionFlow (being it navigation or data flow).		
Activation Expression	Boolean expression associated with a ViewElement, ViewComponentPart or Event: if true the element is enabled		
Interaction Flow Expression	Determine which of the InteractionFlows are going to be followed as consequence of the occurrence of an Event.		Event triggered after selecting a given value in a ComboBox.
Module	Piece of user interface and its corresponding actions, which may be reused for improving IFML models maintainability.		
Input Port	An interaction point between a Module and its environment that collects InteractionFlows and parameters arriving at the module.		

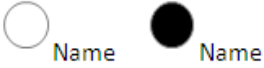
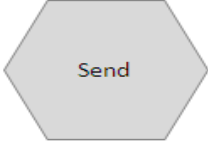
Table 7.1 - Essential IFML Concepts

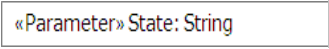
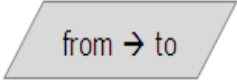
Concept	Meaning	IFML Notation	Example at Implementation level
Output Port	An interaction point between the Module and its environment that collects the InteractionFlows and parameters going out from the module.	 <p>outside the module definition inside the module definition</p>	
View Component Part	A part of a ViewComponent that may not live by its own. It can trigger Events and have outgoing and incoming InteractionFlows. A ViewComponentPart may contain other ViewComponentParts.	<p>«<i>TypeName</i>» [Name][...]</p> <p>«<i>SubTypeName</i>» [Name] [...]</p> <p>«<i>SubTypeName</i>» [Name][...]</p> <p>Examples</p> <p>«DataBinding» MailMessage</p> <p>«ConditionalExpression» MailMessage in MailMessageGroup2MailMessage(MBox)</p> <p>«SimpleField» to: String</p>	Fields in a form

Table 7.2 - Extension IFML Concepts

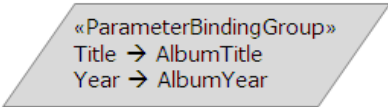
Concept Extension Examples	Meaning	IFML Notation	Example at implementation level
Select Event	Event denoting the selection of a single item of the user interface.		A selection of a row in a table.

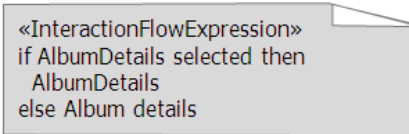
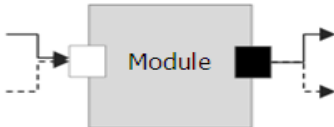
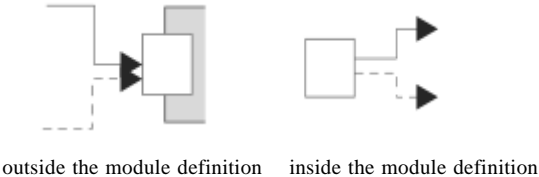
Table 7.2 - Extension IFML Concepts





Submit Event	Event that triggers a parameter passing between interaction flow elements.		A form submission button in HTML.
List	ViewComponent used to display a list of DataBinding instances.		Table with rows of elements of the same kind.
Form	ViewComponent used to display a form that is composed of Fields.		HTML form
Details	ViewComponent used to display details of a specific DataBinding instance.		
Window	A ViewContainer rendered as a window.		An HTML page or a desktop window.

Table 7.2 - Extension IFML Concepts

<p>Modal Window</p>	<p>A ViewContainer rendered in a new window that, when displayed, blocks interaction in all other previously active containers.</p>	 <p>The diagram shows a rectangular window with a title bar containing the text «Modal» Alert. Below the title bar is a large empty rectangular area representing the content of the alert.</p>	<p>A modal pop-up in HTML.</p>
<p>Modeless Window</p>	<p>A ViewContainer rendered in a new window, that when displayed, is superimposed over all other previously active containers, which remain active.</p>	 <p>The diagram shows a rectangular window with a title bar containing the text «Modeless» Tag Chooser. Below the title bar is a large empty rectangular area representing the content of the tag chooser.</p>	<p>A modeless pop-up in HTML.</p>

8 IFML Metamodel

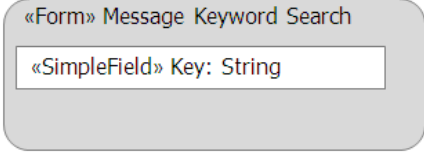
8.1 High-Level Description

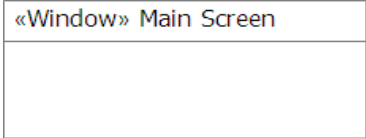
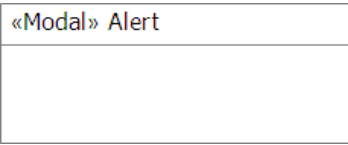
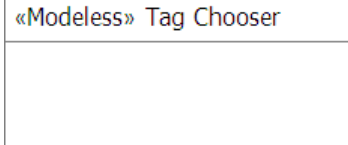
The IFML metamodel is divided in three packages: the Core package, the Extension package, and the DataTypes package. The Core package contains the concepts that build up the interaction infrastructure of the language in terms of InteractionFlowElements, InteractionFlows, and Parameters. Core package concepts are extended by concrete concepts in the Extension package with more complex behaviors. The DataTypes package contains the custom data types defined by IFML.

The IFML metamodel uses the basic data types from the UML metamodel, specializes a number of UML metaclasses as the basis for IFML metaclasses, and presumes that the IFML DomainModel is represented in UML.

The high level description of the IFML metamodel given in the remainder of this sub clause is structured into the following areas of concern:

- IFML Model
- Interaction Flow Model
- Interaction Flow Elements
- View Elements
- Events
- Specific Events and View Components
- Parameters
- Expressions
- ContentBinding

Subsequent sub clauses provide detailed descriptions of the content of each of the three packages.

8.1.1 IFML Model

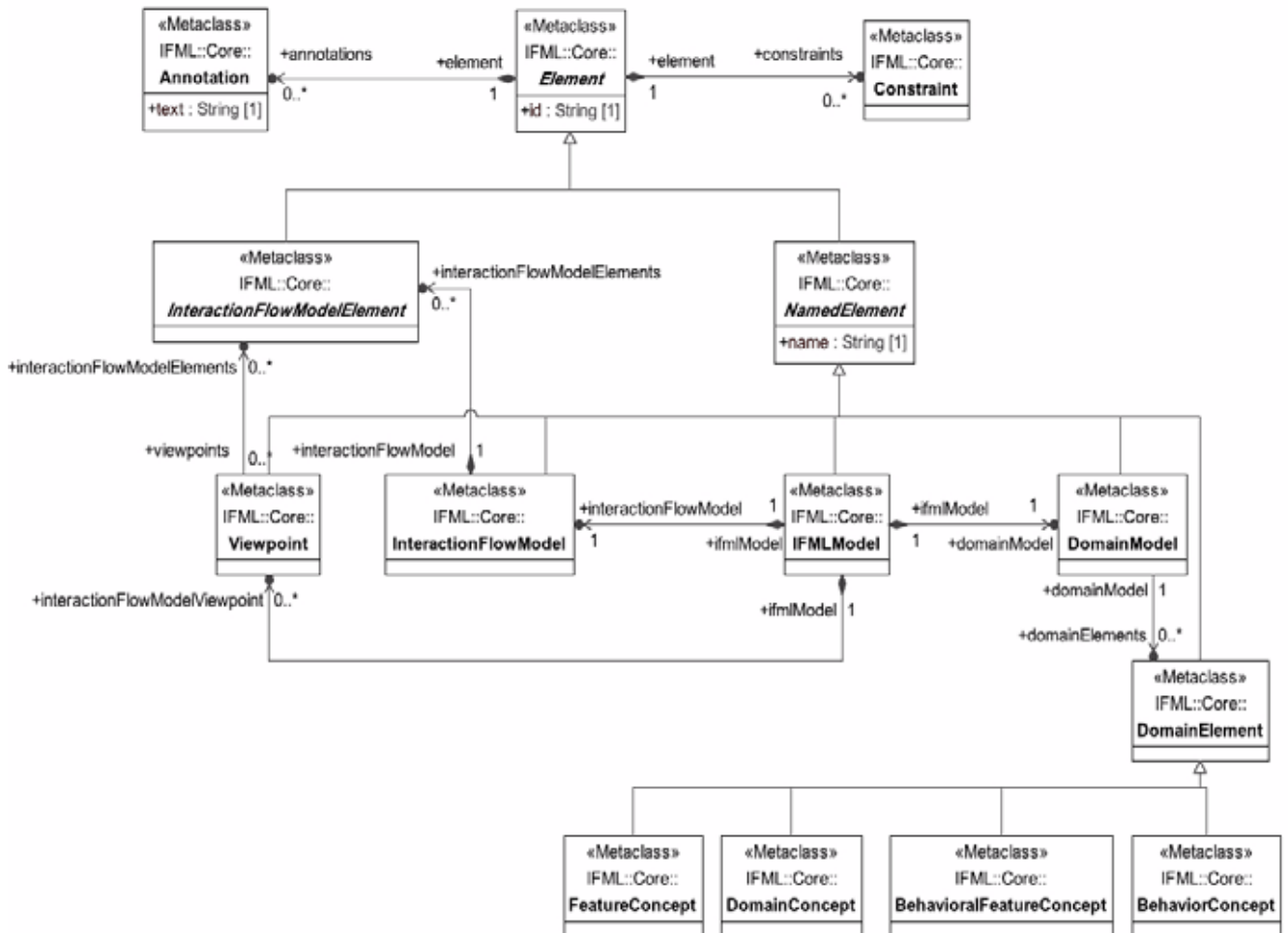

Figure 8.1 - IFML Model

IFMLModel, as its name suggests, represents an IFML model and is the top-level container of all the rest of the model elements. It contains an InteractionFlowModel, a DomainModel, and may optionally contain ViewPoints.

InteractionFlowModel is the user view of the whole application while ViewPoints present only specific aspects of the system by means of references to sets of InteractionFlowModelElements, which as a whole define a fully functional portion of the system. The purpose of a ViewPoint is to facilitate the comprehension of a complex system, to allow or disallow access to the system by a specific UserRole, or to show an adapted piece of the system to a specific context change.

InteractionFlowModelElement is an abstract class, which is the generalization of every element of an InteractionFlowModel.

DomainModel represents the business domain view of the application, i.e., the description of the content and behavior that is dealt with (and referenced) within the InteractionFlowModel. The DomainModel comprises DomainElements, which are specialized as concepts, properties, behaviors, and methods (DomainConcept, FeatureConcept, BehaviorConcept, and BehavioralFeatureConcept respectively).

NamedElement is an abstract class that specializes the Element class (the most general class in the model) denoting the elements that have a name. Besides IFMLModel, InteractionFlowModel, DomainModel, DomainElement, and ViewPoint, NamedElement has other subclasses, which will be described in the contexts where they play a major role.

For any Element, Constraints and Annotations can be specified. Constraints are an extension mechanism to the IFML, in the sense that they may constrain further, for a specific model, the existing IFML syntactical rules.

8.1.2 Interaction Flow Model

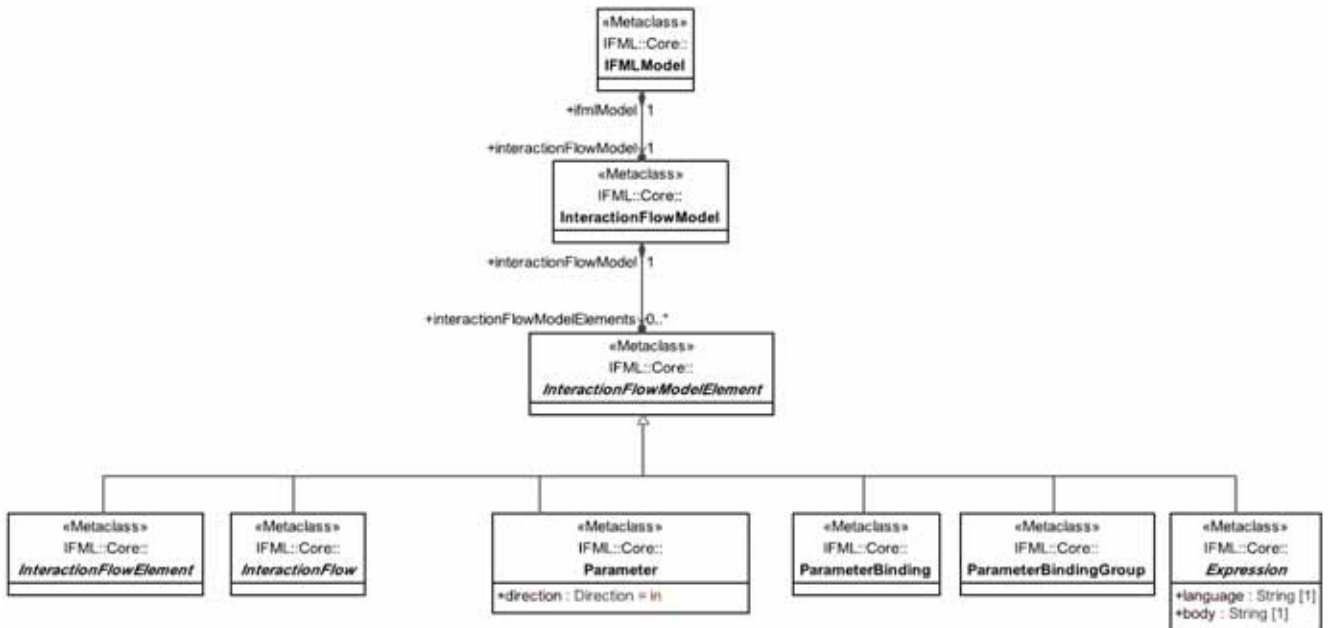

Figure 8.2 - Interaction Flow Model

An InteractionFlowModel contains all the elements of the user view of the application represented by the InteractionFlowModelElement. InteractionFlowModelElement has seven direct subtypes: InteractionFlowElement, InteractionFlow, ParameterBindingGroup, ParameterBinding, Parameter, Expression, and Module.

InteractionFlowElements are the building blocks of interactions. They represent the pieces of the system, which participate in interaction flows through InteractionFlow connections.

An InteractionFlow is a directed connection between two InteractionFlowElements. InteractionFlows may imply navigation along the user interface or only a transfer of information by carrying parameter values from one InteractionFlowElement to another.

A Parameter is a typed name, whose instances hold values. Parameters are held by InteractionFlowElements i.e., ViewElements, ViewComponentParts, Ports, and Actions. Parameters flow between InteractionFlowElements when Events are triggered. Considering the flow of a Parameter P from an InteractionFlowElement A to an InteractionFlowElement B, the Parameter P is considered as an output parameter of InteractionFlowElement A and as an input Parameter of InteractionFlowElement B.

ParameterBindings determine to which input Parameter of a target InteractionFlowElement an output Parameter of a source InteractionFlowElement is bound. ParameterBindings are in turn grouped into ParameterBindingGroups.

A Module is a fully functional collection of InteractionFlowModelElements, which may be reused for improving IFML maintainability. Modules may be replaced by other Modules or InteractionFlowElements with the same input and output parameters.

An Expression defines a statement that will evaluate in a given context to a single instance, a set of instances, or an empty result. An Expression is side effect free. Specific kinds of expression, such as boolean expressions, etc., are represented as specializations of Expression.

The interactions between all these elements will be described in the following sub clauses.

8.1.3 Interaction Flow Elements

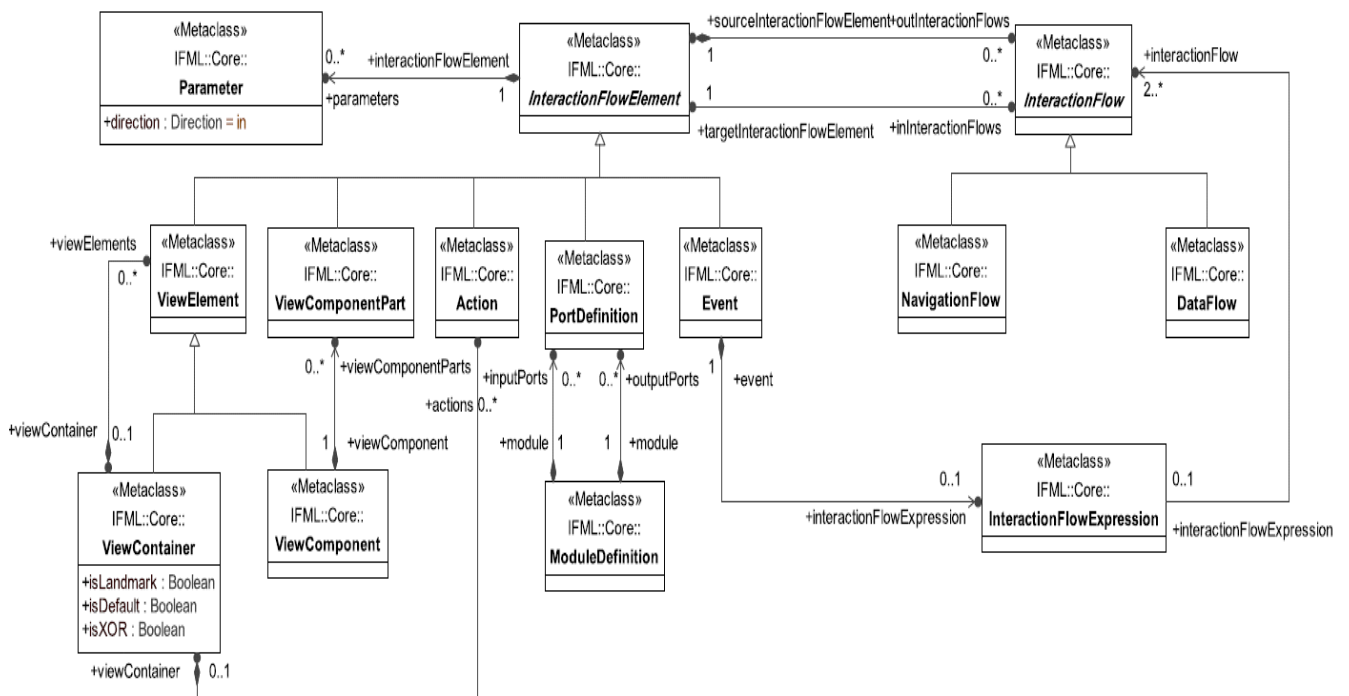

Figure 8.3 - Interaction Flow Elements

The InteractionFlowElement is one of the key concepts of IFML. InteractionFlowElements represent pieces of the system, such as ViewElements, ViewComponentParts, Ports, Actions and Events, which participate in InteractionFlow connections. InteractionFlowElements contain Parameters, which usually flow between InteractionFlowElements as a consequence of ViewElementEvents (user events), ActionEvents, or SystemEvents. InteractionFlowElements may have both incoming and outgoing interaction flows.

InteractionFlows are specialized into NavigationFlows and DataFlows. A NavigationFlow represents navigation or change of ViewElement focus, the triggering of an Action processing, or a SystemEvent. NavigationFlows are followed when Events are triggered. NavigationFlows connect Events of ViewContainers, ViewComponents, ViewComponentParts, or Actions with other InteractionFlowElements. When a NavigationFlow is followed Parameters may be passed from the

source InteractionFlowElement to the target InteractionFlowElement through ParameterBindings. A DataFlow is a kind of InteractionFlow used for passing context information between InteractionFlowElements. DataFlows are triggered by NavigationFlows, causing Parameter passing but no navigation.

Events may be associated with an InteractionFlowExpression when they have more than one outgoing NavigationFlow. An InteractionFlowExpression is used to determine which of the InteractionFlows will be followed as a consequence of the occurrence of an Event. When an Event occurs and it has no InteractionFlowExpression, all the InteractionFlows associated with the event are followed.

ViewContainers can contain ViewElements (namely other ViewContainers or ViewComponents) or Actions.

8.1.4 View Elements

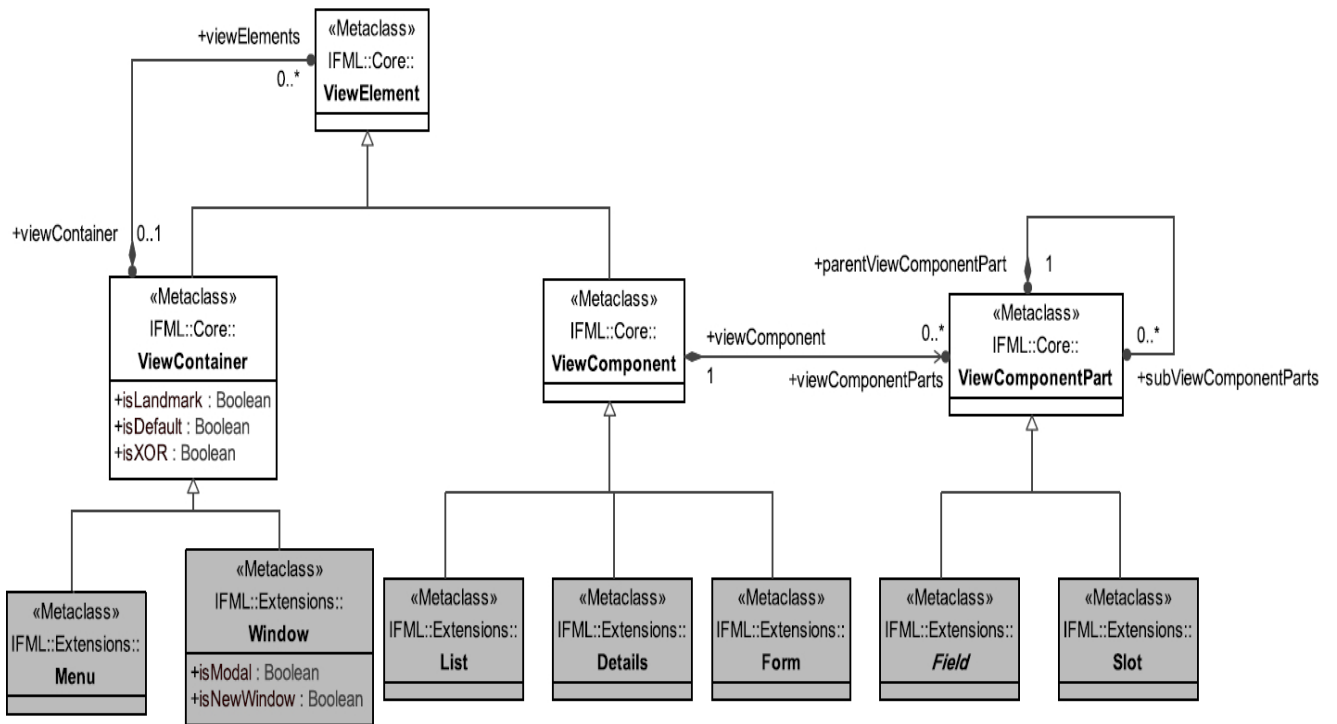

Figure 8.4 - View Elements

The elements of an IFML model that are visible at the user interface level are called ViewElements, which are specialized in ViewContainers and ViewComponents. ViewContainers, like HTML pages or windows, are containers of other ViewContainers or ViewComponents, while ViewComponents are elements of the interface that display content or accept input from the user.

A ViewContainer may be landmark, XOR, and/or default. A landmark ViewContainer may be reached from any other ViewElement without the need of explicit InteractionFlows. ViewContainers that are not landmark may be reached only with an InteractionFlow.

In case a `ViewContainer` (the *enclosed* `ViewContainer`) is contained in another `ViewContainer` (the *enclosing* `ViewContainer`), like a frame in an HTML page, if it is marked as default, it will be presented to the user when its enclosing `ViewContainer` is accessed. Enclosing `ViewContainers` may be marked as XOR. In this case, the contained `ViewElements` of the current `ViewContainer` will be presented to the user only one at a time, as the user interacts with the system. A `ViewContainer` may be also opened as a new window. This new window may be “modal.” Modal windows are meant to block any user interaction in all other previously active containers, until the new window is closed. Another special kind of `ViewContainer` is the `Menu`. `Menus` represent sets of interactive buttons or links that lead to some target container. `Menus` cannot contain subcontainers or `ViewComponents`.

`ViewComponents` exist only inside `ViewContainers`. A `ViewComponent` is an element of the interface that may have dynamic behavior, display content, or accept input. It may correspond e.g., to a form, a data grid, or an image gallery.

A `ViewComponent` may be built up from `ViewComponentParts`. A `ViewComponentPart` is a part of the `ViewComponent` that cannot live outside the context of a `ViewComponent` but may have `Events` and incoming and outgoing `InteractionFlows`. `ViewComponentParts` may hierarchically contain other `ViewComponentParts`. A `ViewComponentPart` may be visible or not at the level of the user interface depending on the kind of `ViewComponentPart`. For instance, a `RichTextField` is a `ViewComponentPart` that is visible to the user, may trigger events, and may receive values through parameter passing, while a `Slot` is a value placeholder that is not visible to the user.

The extension package includes concrete examples of `ViewComponents` such as `List`, `Details` and `Form`, and `ViewComponentParts` such as `Fields` and `Slots`. A `List` is for displaying, selecting, and capturing lists of items of the same kind. `Details` is a component for displaying detailed information on a content element. A `Form` is for capturing user input through forms. All these elements will be described in detail in the following sub clauses.

8.1.5 Parameters

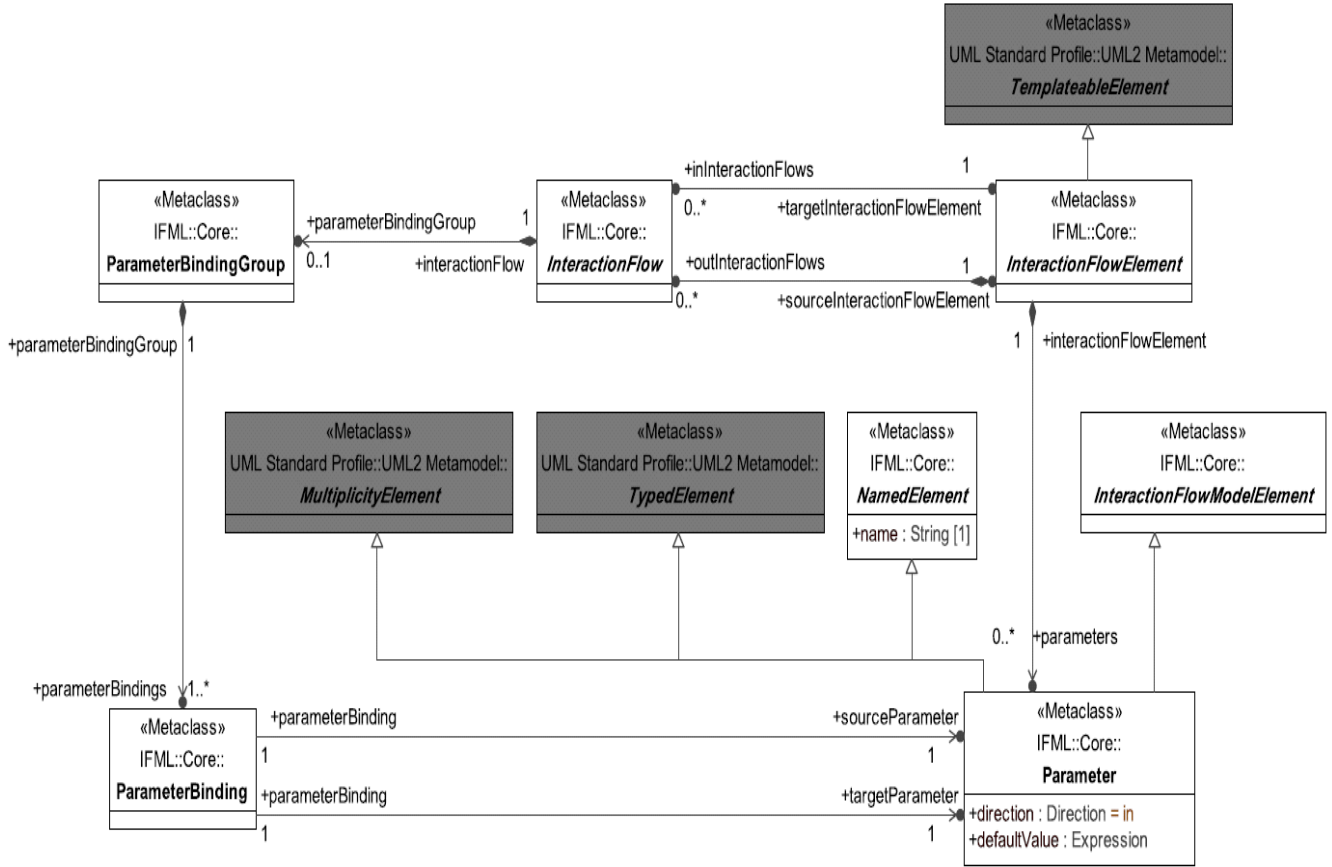

Figure 8.5 - Parameters

A Parameter is a typed element with multiplicity, whose instances hold values. A Parameter may be of a primitive type or a complex type such as object or collection of objects. Parameters are held by InteractionFlowElements and flow between them when Events are triggered. Parameters may be mapped to a single element of the user interface i.e., ViewComponentPart or to a complex hierarchical set of ViewComponentParts.

Parameters have a direction property, which can be input (in), output (out), or input-output (inout). Default direction is input. An input Parameter allows an InteractionFlowElement to receive one or more values through an incoming NavigationFlow or DataFlow. An output Parameter allows an InteractionFlowElement to expose one or more values through an outgoing NavigationFlow or DataFlow. A input-output Parameter allows for both behaviors.

A ParameterBinding determines to which input Parameter of a target InteractionFlowElement an output Parameter of a source InteractionFlowElement is connected and thus how the parameter value will flow when an Event is triggered and the InteractionFlow is followed. ParameterBindings that flow together with an InteractionFlow are grouped by a ParameterBindingGroup, which in turn is related to the InteractionFlow.

8.1.6 Events

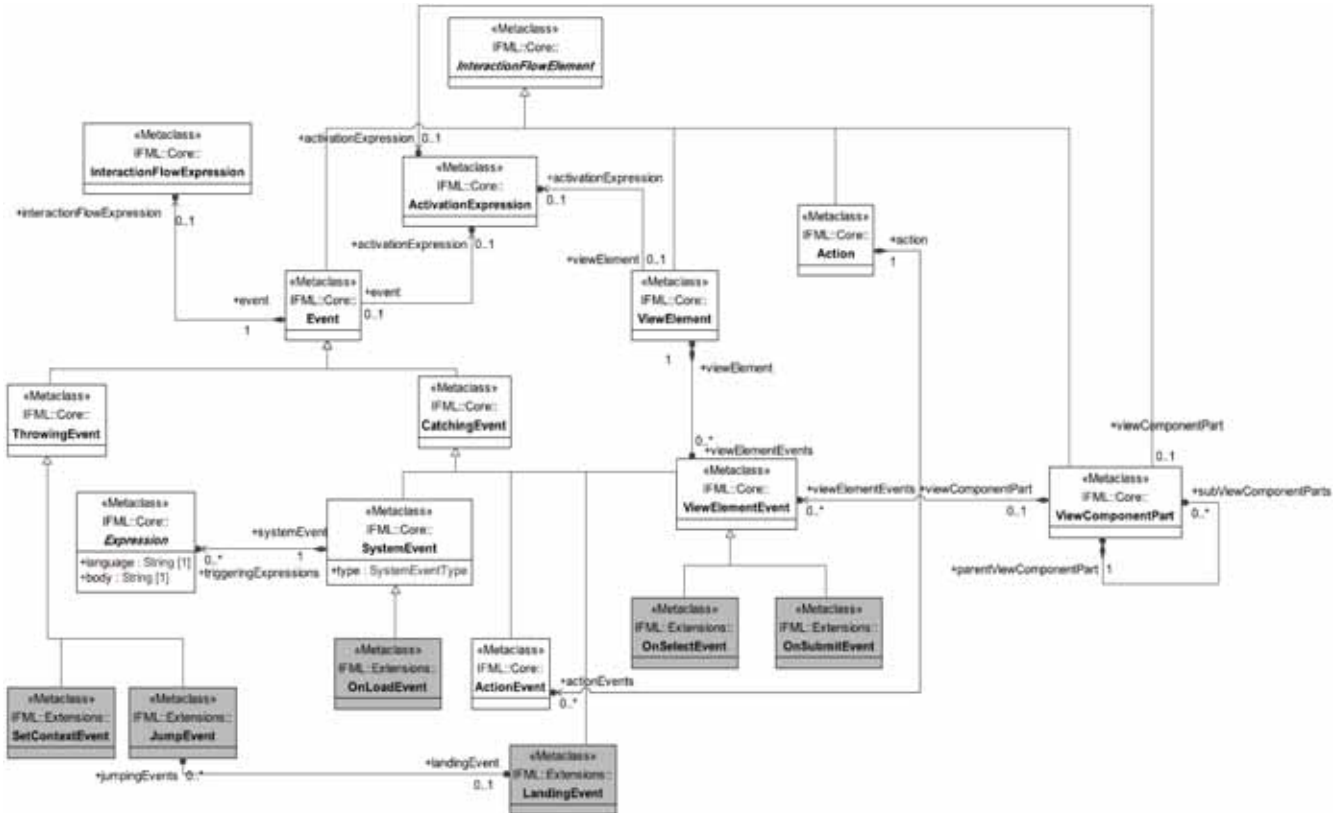

Figure 8.6 - Events

Events are occurrences that can affect the state of the application, and they are a subtype of `InteractionFlowElement`. Events are classified in two main categories: `CatchingEvents` (events that are captured in the UI and that trigger a subsequent interface change) and `ThrowingEvents` (events that are generated by the UI). There are three types of `CatchingEvents`: `ViewElementEvents`, resulting from a user interaction (with specific subtypes `OnSelectEvent` and `OnSubmitEvent`), `ActionEvents`, and `SystemEvents` (such as `OnLoadEvent`).

`ViewElementEvents` are owned by their related `ViewElements`. This means that `ViewElements` contain `Events` that allow a user to activate an interaction in the application, e.g., with the click on a hyperlink or on a button. `ActionEvents` are owned by their related `Actions`. An `Action` may trigger `ActionEvents` during its execution or when it terminates, normally or with an exception.

`SystemEvents` are stand-alone events, which are at the level of the `InteractionFlowModel`. `SystemEvents` result from an `Action` execution termination event or a `triggeringExpression` such as a specific moment in time, or special condition events such as a problem in the network connection.

`CatchingEvents` own a set of `NavigationFlows`. An `InteractionFlowExpression` is used to determine which of the `NavigationFlows` are followed as a consequence of the occurrence of an `Event`. When an `Event` occurs and it has no `InteractionFlowExpression`, all the `NavigationFlows` associated with the event are followed.

An Event may have an ActivationExpression that determines whether the Event is enabled or disabled. In practical terms, disabling a ViewElementEvent means, for example, that the UI element (e.g., a button) that triggers an InteractionFlow is disabled.

8.1.7 Expressions

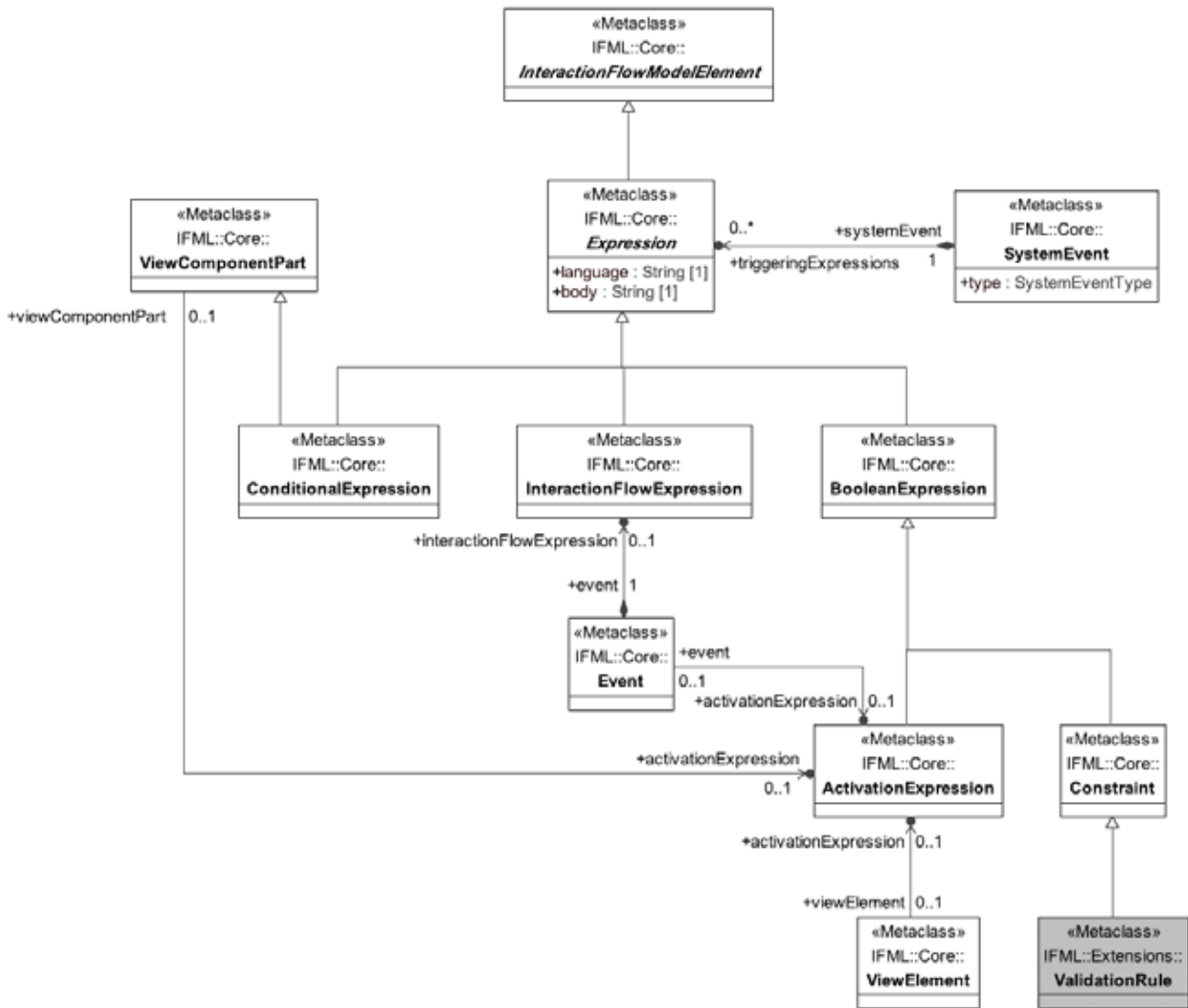

Figure 8.7 - Expressions

An Expression defines a side-effect free statement that will evaluate in a given context to a single instance, a set of instances, or an empty result.

The subtypes of Expression are InteractionFlowExpression, BooleanExpression, and ConditionalExpression.

An InteractionFlowExpression, as discussed in 8.1.3, determines which NavigationFlow should be followed, when more than one NavigationFlow comes out from an Event.

A ConditionalExpression is a ViewComponentPart representing predefined queries contained by DataBindings (see 8.1.8) that may be executed on them to obtain specific content information from the DomainModel. ConditionalExpressions can be defined only inside a DataBinding ViewComponentPart.

A BooleanExpression is an expression that evaluates to true or false. BooleanExpression has the specializations ActivationExpression and Constraint. An ActivationExpression determines if a ViewElement, ViewComponentPart or Event is enabled, and thus available to the user for interaction, while a Constraint restricts the behavior of any element.

The values used to evaluate the expressions are defined depending on the specific Expression type. For instance SystemEvent expressions may have as scope specific system condition values, the current date and time, etc., not modeled in IFML.

8.1.8 Content Binding

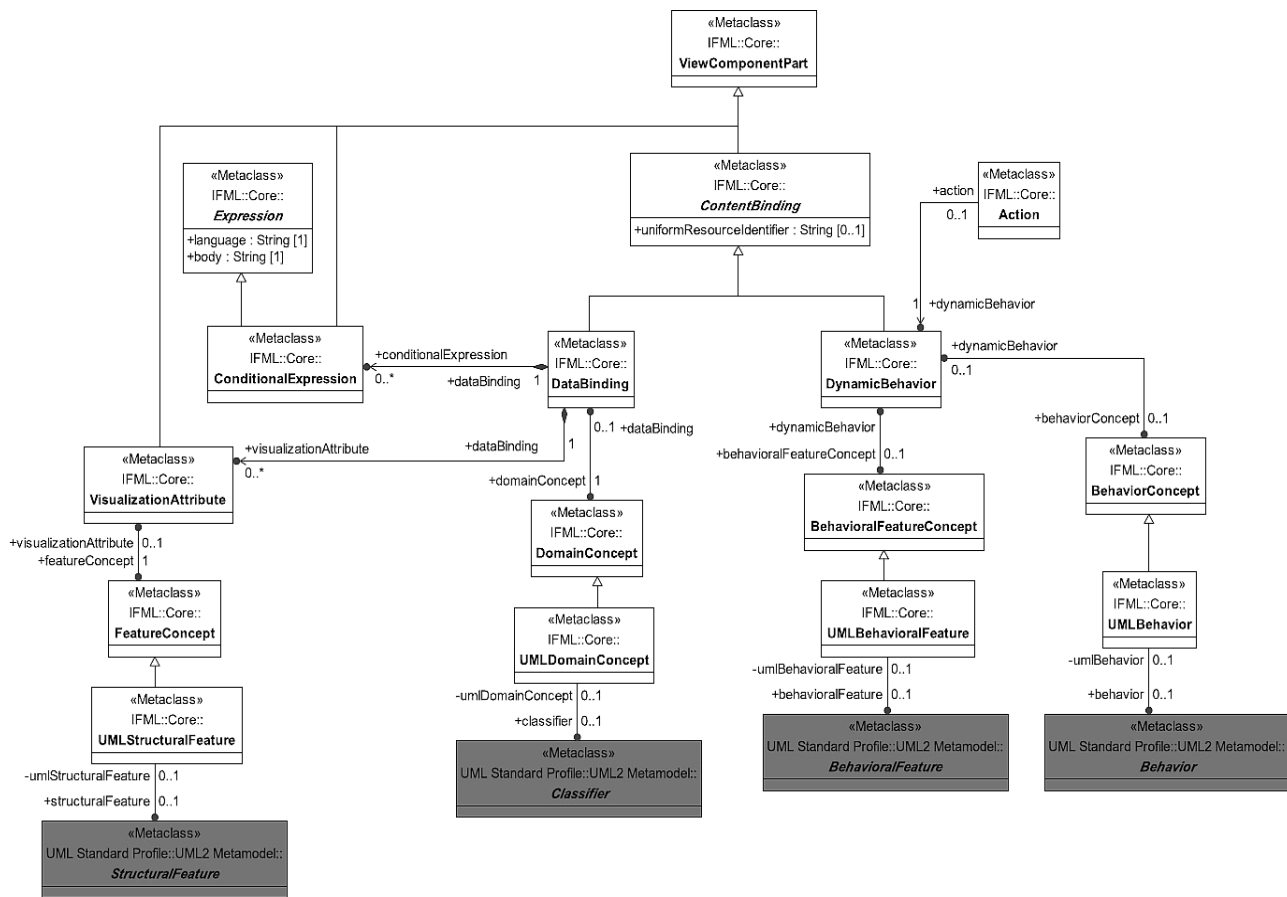

Figure 8.8 - Content Binding

ViewComponents may retrieve content by means of the ContentBinding. ContentBinding represents any source of content. ContentBinding has as an optional attribute the URI of the resource from which the content may be obtained.

ContentBinding is specialized in two concepts, DataBinding and DynamicBehavior. A DataBinding references a DomainConcept (for instance, a Classifier in UML) that may represent an object, an XML file, a table in a database, etc. A DataBinding is associated with a ConditionalExpression, which determines the specific content to be obtained from the content source. A DynamicBehavior represents a content access or business logic such as a service or method that returns a result after an invocation, as represented by a BehavioralFeature or Behavior in UML.

A DataBinding contains VisualizationAttributes used by ViewComponents to determine the features accessed from the DataBinding that may be shown to the user, such as a data base column or an XML element or attribute, as represented using UML StructuralFeatures.

8.1.9 Context

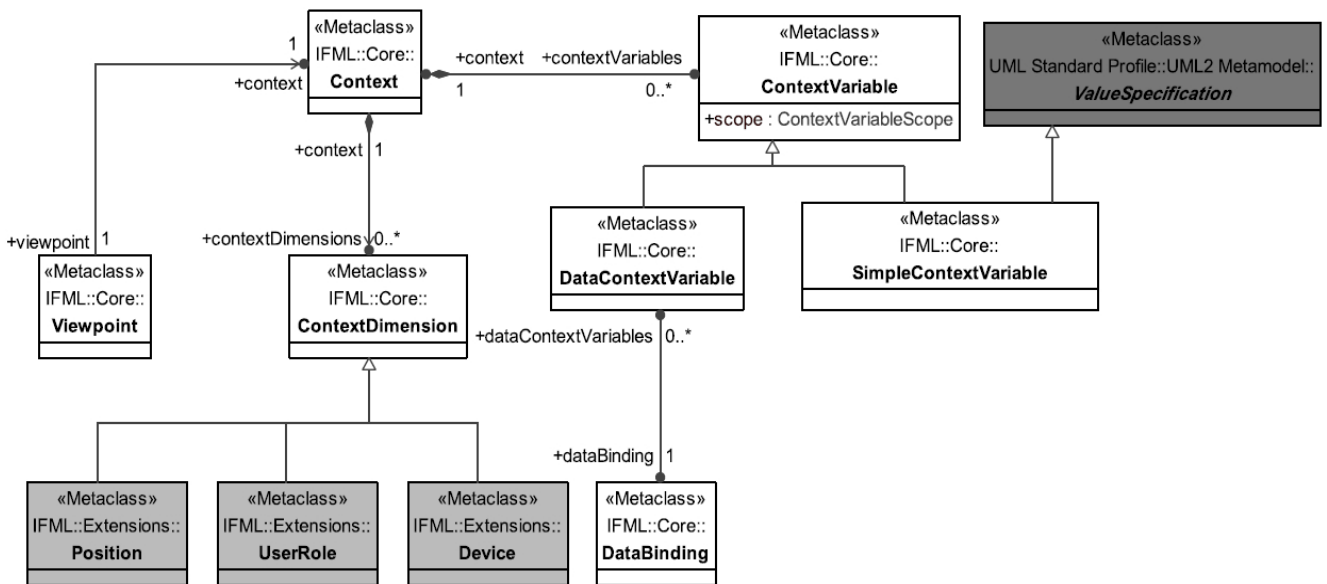

Figure 8.9 - Context

The Context is a runtime aspect of the system that determines how the user interface should be configured and the content that it may display. The configuration and content of the user interface is determined by the ViewPoint, and thus Context is related to ViewPoint.

A Context has several dimensions called ContextDimensions, which represent not only the user’s id and preferences but also the interaction environment of the system. ContextDimension has the specializations UserRole, Device, and Position. When the user context satisfies all the ContextDimensions, access is granted to the ViewElements of the ViewPoint and to the Events that may be triggered on them.

UserRole represents the profile that a user should have for satisfying the UserRole dimension.

A Device represents a specific kind of device for which the ViewPoint is configured. When a user accesses the application through such a device, the Device dimension is satisfied.

Position represents the location and orientation of the device for which a ViewPoint is configured. When the device the user uses for accessing the application reaches the given position or orientation, the Position dimension is satisfied.

ContextDimension may be specialized to represent other dimensions, such as user preferences, etc.

ContextVariables can be associated to the Context to store primitive values (SimpleContextVariable) or objects (DataContextVariable) that store the state of the system in the current context.

8.1.10 Specific ViewComponents

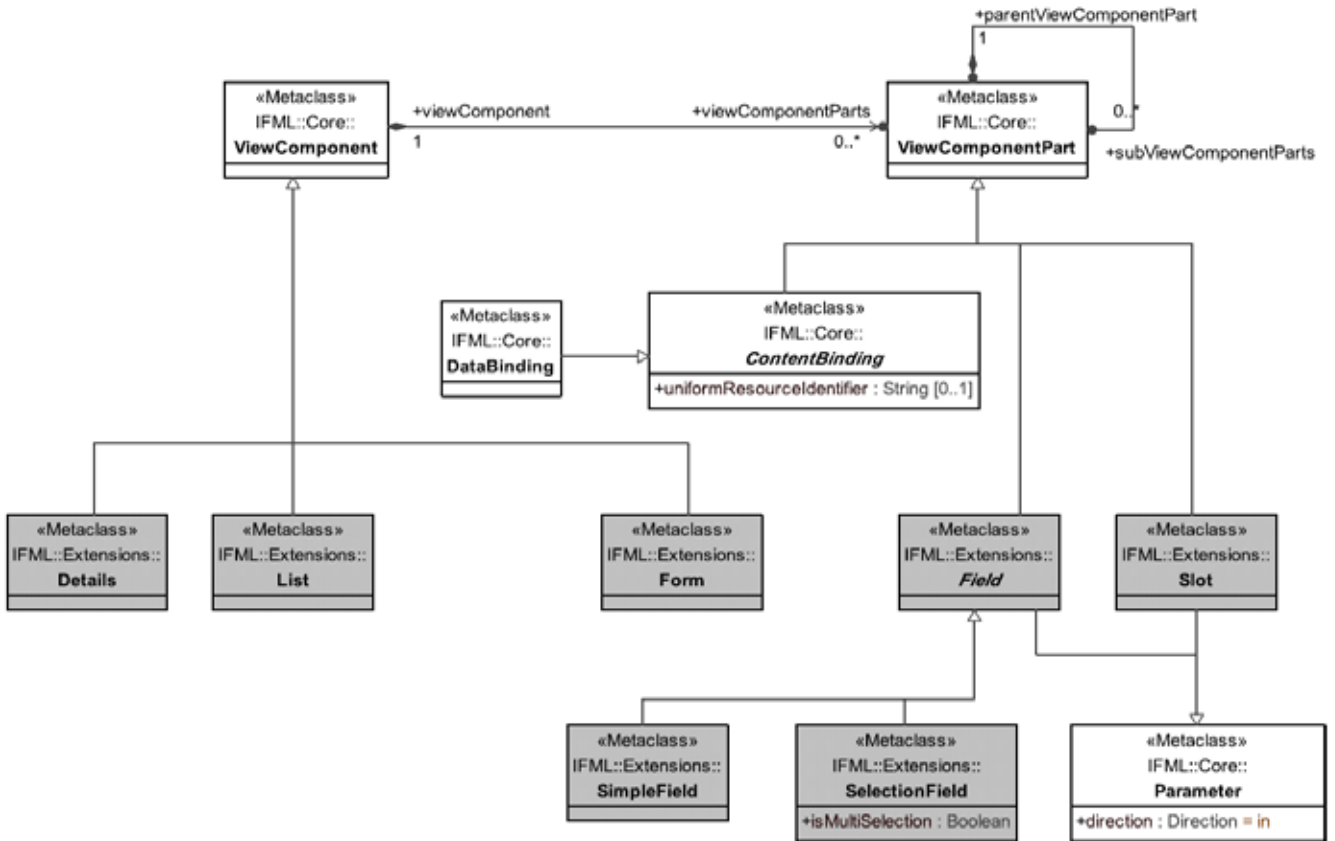

Figure 8.10 - Specific ViewComponents

IFML includes a basic set of extensions to the core elements that exemplify how IFML may be extended.

List, Details, and Form are specializations of ViewComponent (see 8.1.4). The List ViewComponent is used to display a list of DataBinding instances. When a List ViewComponent is associated with an Event, it means that each DataBinding instance displayed by the component may trigger that Event. The Event will in turn cause the passing of the parameter values mapped to the DataBinding instance to a target InteractionFlowElement. The Details ViewComponent is used to display detailed information of a DataBinding instance. When the Details ViewComponent is associated with an Event, the triggering of the Event will cause the passing of the Parameter values mapped to the DataBinding instance to a target InteractionFlowElement. The Form ViewComponent is used to display a form, which is composed of Fields that may display or capture content from the user. Fields have Slots that hold their value. When the Field is a SelectionField, its associated Slots contain the available selection options and the selected one. When the Field is a SimpleField, the Slot

Module is the concept that enables reuse of ModuleDefinitions. Module has a reference to the relevant ModuleDefinition and is associated with a set of Ports, which in turn reference the corresponding PortDefinitions. An input Port (i.e., a Port referencing an input PortDefinition) has incoming InteractionFlows from the outside of the Module, for receiving input Parameters. An output Port has outgoing InteractionFlows to the outside of the Module, for shipping output Parameters.

8.2 Package DataTypes

8.2.1 Enumeration Direction

Description

Enumeration specifying the different possible directions of parameters.

Literals

- in (input): An input Parameter allows an InteractionFlowElement to receive one or more values through an incoming NavigationFlow or DataFlow.
- out (output): An output Parameter allows an InteractionFlowElement to expose one or more values through an outgoing NavigationFlow or DataFlow.
- inout (input-output): A Parameter of kind input-output allows for both behaviors.

8.2.2 Enumeration ContextVariableScope Description

Description

Enumeration specifying the different scope levels for ContextVariables.

Literals

- ApplicationScope: Scope of the ContextVariable is the application
- SessionScope: Scope of the ContextVariable is the user session
- ViewContainerScope: Scope of the ContextVariable is the ViewContainer (for instance, the Web page or the window)

8.2.3 Enumeration SystemEventType

Description

Enumeration specifying the different system event types.

Literals

- actionCompletion: Kind of Event triggered by a business operation completion.
- specialCondition: System special condition event such as data base connection loss, network loss, etc.
- time: System event of time kind, such as absolute time event, periodic time event, and time out event.

8.3 Package Core

8.3.1 Class Action

Abstract: No

Generalization:

- [InteractionFlowElement](#)
- NamedElement

Description

An Action is an InteractionFlowElement that represents a piece of business logic triggered by an Event. Actions may reference behavior models describing the actual business logic to be performed. Actions may trigger different Events called ActionEvents as the result of business logic computation termination or the occurrence of exceptions. Actions may reside on the server or on the client side. If no ActionEvent (and corresponding outgoing flow) is specified, IFML assumes as default an ActionEvent and NavigationFlow that lead back to the ViewComponent or ViewContainer from which the navigation to the Action was launched.

Constraints

- actionsCannotCallActions
self.actionEvent->forAll(e | e.navigationFlow->forAll(nf | not nf.targetInteractionFlowElement.oclIsTypeOf(IFML::Core::Action)))

Association Ends

- actionEvents[0..*]: [ActionEvent](#) - Events triggered by the Action.
- dynamicBehavior [1]: [DynamicBehavior](#) - The business logic to be carried out by the Action.
- viewContainer [0..1]: ViewContainer - The ViewContainer that contains the current Action.

8.3.2 Class ActionEvent

Abstract: No

Generalization:

- CatchingEvent

Description

An ActionEvent is an Event that may be triggered by an Action such as a normal termination event or exception event.

8.3.3 Class ActivationExpression

Abstract: No

Generalization:

- [BooleanExpression](#)

Description

ActivationExpressions are used by ViewElements, Events, or ViewComponentParts to determine if they are enabled or not. An ActivationExpression is a BooleanExpression such that, if it evaluates to true, the element is active, otherwise the element is inactive. ActivationExpressions use Parameter values for the expression evaluation.

8.3.4 Class ActivityConcept

Abstract: No

Generalization:

- NamedElement

Description

ActivityConcepts are an abstract concept describing the idea of business action that can be implemented through an IFML ModuleDefinition. Typical examples could be BPMN Activities or Activities in UML Activity Diagrams.

Association Ends

- moduleDefinition [1]: ModuleDefinition - The ModuleDefinition that implements the business process ActivityConcept.

8.3.5 Class Annotation

Abstract: No

Description

An Annotation represents a comment, note, explanation, or other type of documentation that can be attached to any Element.

Attributes

- text: String - Annotation text.

8.3.6 Class BehaviorConcept

Abstract: No

Generalization:

- DomainElement

Description

BehaviorConcept represents the generic Behavior (for instance, a UML dynamic diagram) that can be referenced as DynamicBehavior in a ContentBinding.

Association Ends

- dynamicBehavior [0..1]: DynamicBehavior - Placeholder in a ContentBinding of the Behavior to be executed by the Action or ViewComponent.

8.3.7 Class BehavioralFeatureConcept

Abstract: No

Generalization:

- DomainElement

Description

BehavioralFeatureConcept represents the generic BehavioralFeature of a DomainModel element (for instance, a Class method) that can be referenced as DynamicBehavior in a ContentBinding.

Association Ends

- dynamicBehavior: DynamicBehavior - Placeholder in a ContentBinding of the BehavioralFeature to be executed by the Action or ViewComponent.

8.3.8 Class BooleanExpression

Abstract: No

Generalization:

- [Expression](#)

Description:

A BooleanExpression is a kind of Expression that evaluates to true or false.

8.3.9 Class BPMNActivityConcept

Abstract: No

Generalization:

- ActivityConcept

Description

BPMNActivityConcepts are a specialization of ActivityConcept for representing the particular case of BPMN Activities.

Association Ends:

- Activity [0..1] : Activity - Reference to a BPMN Activity

8.3.10 Class CatchingEvent

Abstract: No

Generalization:

- Event

Description

A CatchingEvent is an occurrence that can affect the state of the application, by causing navigation and/or Parameter value passing between InteractionFlowElements. CatchingEvents may be produced by a user interaction (ViewElementEvent), by an action when it finishes its execution (ActionEvent), or by the system in the form of notifications (SystemEvent), or by a navigational jump (JumpEvent) in the model that reaches a LandingEvent.

8.3.11 Class ConditionalExpression

Abstract: No

Generalization:

- [Expression](#)
- [ViewComponentPart](#)

Description

A ConditionalExpression is a predefined query expression associated with a DataBinding. When a ConditionalExpression is present, the DataBinding is queried by applying the query in the ConditionalExpression for retrieving content.

8.3.12 Class Constraint

Abstract: No

Generalization:

- [BooleanExpression](#)

Description

A Constraint is a BooleanExpression that may be defined for any model Element in order to restrict its behavior.

8.3.13 Class ContentBinding

Abstract: Yes

Generalization:

- [ViewComponentPart](#)

Description

A ContentBinding allows the system to access a given source of content. A content source access may be done through a DataBinding or a DynamicBehavior of a DomainModel element.

Attributes

- uniformResourceIdentifier[0..1] : String - URI used to identify or locate the resource from which the content may be obtained.

Constraints

- noViewElementEvent
self.viewElementEvent -> isEmpty()

8.3.14 Class Context

Abstract: No

Generalization:

- [Element](#)

Description

The Context is a runtime aspect of the system that determines how the user interface should be configured. A Context has several dimensions that represent not only the user's identity and preferences, but also the interaction environment of the system. Context is composed of one or more ContextDimensions and may comprise ContextVariables.

Association Ends

- contextDimensions [0..*]: [ContextDimension](#) - ContextDimensions the user context must satisfy to have access to one or more Viewpoints.
- contextVariables [0..*]: ContextVariable - set of ContextVariables whose values are relevant for the current Context.

8.3.15 Class ContextDimension

Abstract: No

Generalization:

- [NamedElement](#)

Description

ContextDimensions are dimensions of the Context that represent not only the user's identity and preferences, but also the interaction environment of the system. ContextDimension has the specializations UserRole, Device, and Position. When the user context satisfies all required ContextDimensions, access is granted to the ViewElements of the Viewpoint and to the Events that may be triggered on them.

8.3.16 Class ContextVariable

Abstract: No

Generalization:

- [NamedElement](#)

Description

ContextVariable is a name-value pair that allows to store information associated to the current Context. It can be a SimpleContextVariable, storing a primitive type value, or a DataContextVariable, referencing a DataBinding.

Attributes

- scope : ContextVariableScope - scope of the ContextVariable.

Association Ends

- context [1] : Context - Context within which the ContextVariable is relevant.

8.3.17 Class DataBinding

Abstract: No

Generalization:

- [ContentBinding](#)

Description

DataBinding represents the binding of the system with an instance of an element of the DomainModel such as a table, an object, an XML file, etc.

Association Ends

- domainConcept [1]: domainConcept - A concept specifying the data structure to which the ViewComponent is bound, such as a UML class, a table in a relational data base, or an XML file.
- conditionalExpressions [0..*]: [ConditionalExpression](#) - ConditionalExpressions that determine how to access the content.
- visualizationAttributes[0..*]: [VisualizationAttribute](#) - VisualizationAttributes that determine the StructuralFeatures that should be shown to the user, such as a data base column or an XML element or attribute.
- dataContextVariables [0..*]: DataContextVariable - reference to the ContextVariable that makes use of the DataBinding.

8.3.18 Class DataContextVariable

Abstract: No

Generalization:

- ContextVariable

Description

DataContextVariable allows to associate a DataBinding to the current Context.

Association Ends

- dataBinding [1]: DataBinding - Reference to the DomainModel concept used as ContextVariable.

8.3.19 Class DataFlow

Abstract: No

Generalization:

- [InteractionFlow](#)

Description

A DataFlow is a kind of InteractionFlow used for passing context information between InteractionFlowElements. DataFlows are triggered by NavigationFlows causing Parameter passing but no navigation. DataFlows are triggered any time a parameter is available in output from the source InteractionFlowElement and transfer the Parameter values to the target InteractionFlowElement. The target of a DataFlow cannot be an Event.

Constraints

- targetNotInstanceOfEvent
not self.targetInteractionFlowElement.ocIsTypeOf(IFML::Core::Event)

8.3.20 Class DomainConcept

Abstract: No

Generalization:

- DomainElement

Description

The DomainConcept represents a generic concept, class, entity of the DomainModel, which can be referenced in a DataBinding. Its purpose is to allow extensibility in terms of concepts from different modeling languages representing the DomainModel.

Association Ends

- dataBinding [0..1]: DataBinding - Reference to the DataBinding in a ViewComponent that uses the current DomainConcept.

8.3.21 Class DomainElement

Abstract: No

Generalization:

- NamedElement

Description

The DomainElement represents a generic element of the DomainModel, which can describe a concept, a property, a behavior, or a behavioral feature. It is a generic representative for classes DomainConcept, FeatureConcept, BehavioralFeatureConcept, BehaviorConcept.

Association Ends

- domainModel [1]: DomainModel - Reference to the DomainModel comprising the DomainElement.

8.3.22 Class DomainModel

Abstract: No

Generalization:

- [NamedElement](#)

Description

The DomainModel is a model that contains content elements that ViewComponents may access to retrieve information, process it, and show it to the user. The DomainModel also stores information captured from the user. The DomainModel is presumed to be represented in UML and therefore consists of a set of UML model elements.

Association Ends

- elements[0..*]: DomainElement - References to the elements of the DomainModel.

8.3.23 Class DynamicBehavior

Abstract: No

Generalization:

- [ContentBinding](#)

Description

DynamicBehavior represents the binding of the system with a service or operation, which may be invoked in order to carry out business logic or return content.

Constraints

- eitherBehavioralFeatureOrBehavior
self.behavioralFeature -> notEmpty() xor self.behavior -> notEmpty()

Association Ends

- behavioralFeatureConcept [0..1]: BehavioralFeatureConcept - Representing a procedure, method, function, etc., that may be invoked by a ViewComponent to carry out business logic or obtain content.
- behaviorConcept [0..1]: BehaviorConcept - Representing a complex behavior specified for instance as a process, activity, or sequence model.

8.3.24 Class Element

Abstract: Yes

Description

Element is the base class for the representation of all model elements in an IFML model.

Attributes

- id: String [1] - String for unequivocally identifying a model element.

Association Ends

- annotations [0..*]: [Annotation](#) - Annotations, comments, tags, etc., owned by the Element.
- constraints [0..*]: [Constraint](#) - Constraints applied to the Element.

8.3.25 Class Event

Abstract: No

Generalization:

- [InteractionFlowElement](#)

Description

An Event is an occurrence that can affect the state of the application. Events can be ThrowingEvent (events that are thrown by the modeled interaction) or CatchingEvent (events that are captured by the modeled interaction and used as triggers causing navigation and/or Parameter value passing between InteractionFlowElements).

Association Ends

- activationExpression [0..1]: [ActivationExpression](#) - Reference to an ActivationExpression whose evaluation result determines if the Event is active or inactive. If no ActivationExpression is given, the default is that the Event is active.
- interactionFlowExpression [0..1]: [InteractionFlowExpression](#) - InteractionFlowExpression determining the InteractionFlows to be followed after the occurrence of the Event.

8.3.26 Class Expression

Abstract: Yes

Generalization:

- [InteractionFlowModelElement](#)

Description

An Expression is an element that, evaluates to a single instance, a set of instances, or an empty result. An Expression must be side effect free. Specific expression types, such as BooleanExpression, etc., specialize this concept.

Attributes

- body[1]: String - Code of the Expression.
- language[1]: String - Language in which the Expression is written, e.g., OCL, Java, etc.

8.3.27 Class FeatureConcept

Abstract: No

Generalization:

- [DomainElement](#)

Description

FeatureConcept represents the generic attribute or property of a DomainModel element, which can be referenced as VisualizationAttribute.

Association Ends

- visualizationAttribute [0..1]: VisualizationAttribute - Placeholder in a DataBinding of the FeatureConcept to be visualized.

8.3.28 Class IFMLModel

Abstract: No

Generalization:

- [NamedElement](#)

Description

An IFMLModel is the top-level container of all other elements in an IFML model. All model elements are grouped into two submodels, the InteractionFlowModel and the DomainModel. An IFMLModel may also contain a number of Viewpoints of the InteractionFlowModel.

Association Ends

- domainModel [1]: [DomainModel](#) - Model describing the domain concepts and behaviors used in the user interaction modeled by the IFML model.
- interactionFlowModel [1]: [InteractionFlowModel](#) - The complete model that describes the interaction of the user with the system.
- viewpoints [0..*]: [Viewpoint](#) - Viewpoints of the InteractionFlowModel.

8.3.29 Class InteractionFlow

Abstract: Yes

Generalization:

- [InteractionFlowModelElement](#)

Description

An InteractionFlow is a directed connection between ViewElements or ViewElements and Actions, which enables communication between them by means of Parameter passing. InteractionFlows are divided into NavigationFlows and DataFlows. NavigationFlows cause navigation or change of focus to the target element and Parameter passing, while DataFlows cause only Parameter passing to the target element.

Association Ends

- parameterBindingGroup [0..1]: [ParameterBindingGroup](#) - Group of parameters that are passed to the target interaction flow element by following the InteractionFlow.
- targetInteractionFlowElement [1]: [InteractionFlowElement](#) - Target InteractionFlowElement of the InteractionFlow.
- sourceInteractionFlowElement [1]: [InteractionFlowElement](#) - Source InteractionFlowElement of the InteractionFlow.

8.3.30 Class InteractionFlowElement

Abstract: Yes

Generalization:

- [InteractionFlowModelElement](#)
- [NamedElement](#)
- TemplateableElement

Description

InteractionFlowElements represent pieces of the system such as Actions, Events, ViewElements, and ViewComponentParts, which participate in user interaction flows through InteractionFlow connections. Usually there is a flow of Parameter values between InteractionFlowElements as a consequence of user, action, or system events.

Association Ends

- inInteractionFlows [0..*]: [InteractionFlow](#) - Incoming InteractionFlows.
- outInteractionFlows [0..*]: [InteractionFlow](#) - Outgoing InteractionFlows.
- parameters [0..*]: [Parameter](#) - Parameters contained by the InteractionFlowElement.

8.3.31 Class InteractionFlowExpression

Abstract: No

Generalization:

- [Expression](#)

Description

An InteractionFlowExpression is used to determine which of the InteractionFlows will be followed as a consequence of the occurrence of an Event. When an Event occurs and it has no InteractionFlowExpression, all the InteractionFlows associated with the event are followed. At least two InteractionFlows must be associated with an InteractionFlowExpression. An InteractionFlowExpression uses the ViewElement Parameter values and the InteractionFlows for the evaluation of the expression.

Association Ends

- interactionFlows [2..*]: [InteractionFlow](#) - InteractionsFlows for which the expression is evaluated.

8.3.32 Class InteractionFlowModel

Abstract: No

Generalization:

- [NamedElement](#)

Description

An InteractionFlowModel aggregates all the elements modeling interaction with the user.

Association Ends

- interactionFlowModelElements [0..*]: [InteractionFlowModelElement](#) - Elements of the InteractionFlowModel.

8.3.33 Class InteractionFlowModelElement

Abstract: Yes

Generalization:

- [Element](#)

Description

An InteractionFlowModelElement is the top-level class that generalizes all the elements that are part of an InteractionFlowModel.

8.3.34 Class ModularizationElement

Abstract: No

Generalization:

- [InteractionFlowModelElement](#)
- NamedElement

Description

A ModularizationElement is an abstract concept that represents both ModulePackages and ModuleDefinitions.

Association Ends

- modulePackage [0..1]: ModulePackage - The ModulePackage containing the ModularizationElement.

8.3.35 Class Module

Abstract: No

Generalization:

- [InteractionFlowModelElement](#)
- NamedElement

Description

A Module is a named reference to a ModuleDefinition, which allows reuse of the model part specified in the ModuleDefinition. Module has a reference to the relevant ModuleDefinition and may be associated with a set of Ports, which in turn reference the corresponding PortDefinitions. For every PortDefinition in the ModuleDefinition there shall be 0 or 1 Ports in each corresponding Module. An input Port (i.e., a Port referencing an input PortDefinition) has incoming InteractionFlows from the outside of the Module, for receiving input Parameters. An output Port has outgoing InteractionFlows to the outside of the Module, for shipping output Parameters.

Constraints

- onlyOnePortPerPortDefinition
self.moduleDefinition.portDefinitions -> forAll(pd | pd.ports -> select(p|p.module = self) -> size() = 1)

Association Ends

- ports[0..*]: [Port](#) - Ports that collect InteractionFlows and Parameters incoming or outgoing from the Module.
- ModuleDefinition [1]: ModuleDefinition - The ModuleDefinition that is instantiated by the current Module.

8.3.36 Class ModuleDefinition

Abstract: No

Generalization:

- [ModularizationElement](#)

Description

A ModuleDefinition is a fully functional collection of user InteractionFlowModelElements and their corresponding Actions, which may be reused for improving IFML model maintainability. ModuleDefinitions can be aggregated in a hierarchical structure of ModulePackages. ModuleDefinitions may comprise PortDefinitions. A ModuleDefinition receives Parameter values from outside and provides Parameter values to the outside. ModuleDefinitions exchange Parameters by means of input and output PortDefinitions. InteractionFlowModelElements contained in a Module may not be shared or referenced by other Modules or by the main InteractionFlowModel. A ModuleDefinition may comprise a reference to a BPMN Activity (meaning that the Module implements that Activity). Reuse of ModuleDefinition is obtained by adding Modules referencing that ModuleDefinition in IFML models.

Association Ends

- inputPorts [0..*]: [PortDefinition](#) - Ports that distributes InteractionFlows and Parameters coming into the Module.
- interactionFlowModelElements [1..*]: [InteractionFlowModelElement](#) - InteractionFlowModelElements contained by the Module.
- outputPorts [0..*]: [PortDefinition](#) - Ports that collect the InteractionFlows and Parameters going out from the Module.
- modules [0..*]: Module - The set of Modules that are defined in the IFML model and reference the current ModuleDefinition.
- activityConcept [0..1]: ActivityConcept - Reference to a process activity (e.g., a BPMN Activity). If present, the current module describes the technical implementation of the process activity.

8.3.37 Class ModulePackage

Abstract: No

Generalization:

- [ModularizationElement](#)

Description

A ModulePackage is a container of ModuleDefinitions. ModulePackages can be nested in arbitrarily deep hierarchical structure.

Association Ends

- inputPorts [1..*]: [Port](#) - Ports that distribute InteractionFlows and Parameters coming into the Module.
- modularizationElements [0..*]: [ModularizationElement](#) - Set of [ModularizationElement](#)s contained in the current ModulePackage.

8.3.38 Class NamedElement

Abstract: Yes

Generalization:

- [Element](#)

Description

A NamedElement is an Element that requires a name for easy visual identification in diagrams or for being handled as a named variable in a concrete textual syntax.

Attributes

- name[1]: String - Element name.

8.3.39 Class NavigationFlow

Abstract: No

Generalization:

- [InteractionFlow](#)

Description

A NavigationFlow represents navigation or change of ViewElement focus, the triggering of Action processing, or a SystemEvent. NavigationFlows are followed when Events are triggered. NavigationFlows connect Events of ViewContainers, ViewComponents, ViewComponentParts, or Actions with other InteractionFlowElements. When a NavigationFlow is followed, Parameters may be passed from the container of the source Event to the target InteractionFlowElement through ParameterBindings. When a NavigationFlow is triggered, a corresponding set of DataFlows may be triggered, at the purpose of carrying further parameters to the target InteractionFlowElement. The DataFlows that are triggered are all the ones having some parameter values available as an effect of the last interface status change.

8.3.40 Class Parameter

Abstract: No

Generalization:

- [InteractionFlowModelElement](#)
- MultiplicityElement
- TypedElement
- NamedElement

Description

A Parameter is a typed name, whose instances hold values. Parameters are held by InteractionFlowElements, i.e., ViewElements, ViewComponentParts, Ports, and Actions. Parameters flow between InteractionFlowElements when Events are triggered. Parameters may correspond to elements of the user interface (for instance, fields in a form), determining whether the element of the user interface is read-only or modifiable. Parameters have a direction property, which can be input (in), output (out), or input-output (inout). Default direction is input.

The scope of a Parameter (i.e., the model space where it can be used or referenced) is the InteractionFlowElement that holds the Parameter, plus the incoming and outgoing InteractionFlows. This means that:

- if the parameter is held by a ViewComponent, it can be referenced only within the ViewComponent itself and the contained ViewComponentParts (plus the incoming and outgoing InteractionFlows);
- if the parameter is held by a ViewContainer, it can be referenced within the ViewContainer itself, and within the contained ViewContainers, ViewComponents, and ViewComponentParts (plus the incoming and outgoing InteractionFlows).

A Parameter can have a default value.

Attributes

- direction: Direction - Determines if the parameter direction is input, output, or input-output.
- defaultValue: Expression - default value of the parameter, calculated through the specified expression.

8.3.41 Class ParameterBinding

Abstract: No

Generalization:

- [InteractionFlowModelElement](#)

Description

A ParameterBinding determines how data flow between components. A ParameterBinding connects an output Parameter of a source InteractionFlowElement with an input Parameter of a target InteractionFlowElement. When an Event is triggered, InteractionFlows are followed and Parameter values flow from source InteractionFlowElements to target InteractionFlowElements, according to how they have been bound.

Association Ends

- sourceParameter [1]: [Parameter](#) - Output Parameter of the source InteractionFlowElement that participates in the ParameterBinding.
- targetParameter [1]: [Parameter](#) - Input Parameter of the target InteractionFlowElement that participates in the ParameterBinding.

8.3.42 Class ParameterBindingGroup

Abstract: No

Generalization:

- [InteractionFlowModelElement](#)

Description

A ParameterBindingGroup aggregates all the ParameterBindings of an InteractionFlow.

Association Ends

- parameterBindings [1..*]: [ParameterBinding](#) - The ParameterBindings composing the ParameterBindingGroup.

8.3.43 Class Port

Abstract: No

Generalization:

- [InteractionFlowElement](#)

Description

A Port is an interaction point between a Module and the surrounding model within which it is defined.

Module is associated with a set of Ports, which in turn reference the corresponding PortDefinitions. An input Port (i.e., a Port referencing an input PortDefinition) has incoming InteractionFlows from the outside of the Module, for receiving input Parameters. An output Port has outgoing InteractionFlows to the outside of the Module, for shipping output Parameters.

Association Ends

- PortDefinition [1]: PortDefinition - Reference to the PortDefinition that defines the interface of the current Port.
- module [1]: Module - Module that contains the current Port.

8.3.44 Class PortDefinition

Abstract: No

Generalization:

- [InteractionFlowElement](#)

Description

PortDefinitions represent interaction points with a ModuleDefinition. They are defined within a ModuleDefinition. They hold Parameters, for transferring values to and from the ModuleDefinition. An input PortDefinition has outgoing InteractionFlows to the inside of the Module. An output PortDefinition has incoming InteractionFlows from the inside of the Module. Modules that reference a ModuleDefinition may comprise Ports, which in turn reference the corresponding PortDefinitions.

Association Ends

- ports [0..*]: Port - Set of Ports referencing the current PortDefinition in some Modules implementing the ModuleDefinition within which the current PortDefinition is defined.

8.3.45 Class SimpleContextVariable

Abstract: No

Generalization:

- ValueSpecification

Description

SimpleContextVariable is a typed name-value pair that can be associated to the current Context. Allowed types are the primitive ones.

8.3.46 Class SystemEvent

Abstract: No

Generalization:

- Catching[Event](#)

Description

A SystemEvent is an Event produced by the system, which triggers a computation reflected in the user interface. Examples of SystemEvents are time events, which are triggered after an elapsed frame of time, or system special conditions events, such as a database connection loss event.

Attributes

- type: SystemEventType - Determines the kind of SystemEvent.

Association Ends

- triggeringExpressions [0..*]: [Expression](#) - Expressions that determine when or under what conditions the SystemEvent should be triggered.

8.3.47 Class ThrowingEvent

Abstract: No

Generalization:

- Event

Description

A ThrowingEvent is an occurrence of event that is generated by the modeled application. Event occurrences generated by ThrowingEvent can be captured by CatchingEvents.

8.3.48 Class UMLBehavior

Abstract: No

Generalization:

- BehaviorConcept

Description

UMLBehavior represents a Behavior specified in UML (that is, a UML dynamic diagram) which can be referenced as DynamicBehavior in a ContentBinding.

Association Ends

- behavior [0..1]: UML::Behavior - UML Behavior to be executed by the Action or ViewComponent.

8.3.49 Class UMLBehavioralFeature

Abstract: No

Generalization:

- BehavioralFeatureConcept

Description

UMLBehavioralFeature represents a BehavioralFeature specified in UML (typically, a UML method in a Class) which can be referenced as DynamicBehavior in a ContentBinding.

Association Ends

- behavioralFeature [0..1]: UML::BehavioralFeature - UML BehavioralFeature to be executed by the Action or ViewComponent.

8.3.50 Class UMLStructuralFeature

Abstract: No

Generalization:

- FeatureConcept

Description

The UMLStructuralFeature is a specific FeatureConcept referring to a UML StructuralFeature.

Association Ends

- structuralFeature [0..1]: UML::StructuralFeature - Reference to the UML element of the DomainModel.

8.3.51 Class UMLDomainConcept

Abstract: No

Generalization:

- DomainConcept

Description

The UMLDomainConcept is a specific DomainConcept referring to a UML Classifier.

Association Ends

- classifier [0..1]: [UML::Classifier](#) - Reference to the UML Classifier of the DomainModel that will be connected to a ViewElement through a DataBinding.

8.3.52 Class ViewComponent

Abstract: No

Generalization:

- [ViewElement](#)

Description

A ViewComponent is an element of the user interface that displays content or accepts input. A ViewComponent may be bound to a ContentBinding through its association with ViewComponentPart.

Association Ends

- viewComponentParts [0..*]: [ViewComponentPart](#) - Parts of the ViewComponent.

8.3.53 Class ViewComponentPart

Abstract: No

Generalization:

- [InteractionFlowElement](#)

Description

A ViewComponentPart is an InteractionFlowElement that may not live outside the context of a ViewComponent. A ViewComponentPart may trigger Events and have incoming and outgoing InteractionFlows.

Association Ends

- activationExpression [0..1]: [ActivationExpression](#) - Reference to an ActivationExpression whose evaluation result determines whether the ViewComponentPart is active or inactive. If no ActivationExpression is given, by default the ViewComponent is active.
- subViewComponentParts [0..*]: [ViewComponentPart](#) - Nested ViewComponentParts.
- viewElementEvents [0..*]: [ViewElementEvent](#) - Events that this ViewComponentPart may trigger.
- parentViewComponentPart [1]: [ViewComponentPart](#) - Parent ViewComponentPart.

8.3.54 Class ViewContainer

Abstract: No

Generalization:

- [ViewElement](#)

Description

A ViewContainer is an element of the interface that aggregates other ViewContainers and/or ViewElements displaying content.

Constraints:

- defaultMustHaveXorParent
self.viewContainer and self.viewContainer.isXor
- xorMustHaveADefaultParent
self.isXor implies self.viewElements -> select(c|c.oclTypeOf(ViewContainer) and c.asOclTypeOf(ViewContainer).isDefault) -> size()=1

Attributes

- isDefault: Boolean - If true, the ViewContainer will be presented to the user when its enclosing ViewContainer is accessed. This attribute is relevant when this ViewContainer shares the same parent ViewContainer with other ViewContainers, and the parent ViewContainer has property isXOR = true.
- isLandmark: Boolean - If true, the ViewContainer is directly reachable from any ViewElement from any ViewElement contained, directly or indirectly, in the same ViewContainer. It represents an implicit link between all the other ViewElements and the ViewContainer.
- isXOR: Boolean - If true, the contained ViewElements of thisViewContainer will be presented to the user only one at a time, as the user interacts with the system. One of the contained ViewContainers must have attribute isDefault = true.

Association Ends

- viewElements [0..*]: [ViewElement](#) - The ViewElements owned by the ViewContainer.
- actions [0..*]: Action - The Actions owned by the ViewContainer.

8.3.55 Class ViewElement

Abstract: No

Generalization:

- [InteractionFlowElement](#)

Description

ViewElements are elements of the user interface that display content. ViewElements are divided into ViewContainers and ViewComponents. ViewContainers are aggregations of other ViewContainers and/or ViewComponents.

Association Ends

- activationExpression [0..1]: [ActivationExpression](#) - Reference to an ActivationExpression whose evaluation result determines whether the ViewElement is active or inactive. If no ActivationExpression is given, by default the ViewElement is active.
 - viewElementEvents [0..*]: [ViewElementEvent](#) - ViewElementEvents contained by the ViewElement.
 - viewContainer [0..1]: [ViewContainer](#) - ViewContainer of the current ViewElement.

8.3.56 Class ViewElementEvent

Abstract: No

Generalization:

- Catching [Event](#)

Description

A ViewElementEvent represents a user interaction Event, which may be triggered by ViewElements (ViewContainers and ViewComponents).

Association Ends

- viewElement [1]: ViewElement - ViewElement owning the ViewElementEvent.

8.3.57 Class Viewpoint

Abstract: No

Generalization:

- [NamedElement](#)

Description

A Viewpoint is a reference to an interrelated set of InteractionFlowModelElements, which as a whole define a functional portion of the system. The purpose of a Viewpoint is to facilitate the comprehension of a complex system, to allow or disallow access to the system by a specific UserRole, or to adapt the system to a specific context change.

Association Ends

- interactionFlowModelElements [0..*]: [InteractionFlowModelElement](#) - InteractionFlowModelElements that build up this Viewpoint.
- context [1]: [Context](#) - Application context that determines the Viewpoint to be used.

8.3.58 Class VisualizationAttribute

Abstract: No

Generalization:

- [ViewComponentPart](#)

Description

The VisualizationAttributes used by a ViewComponent determine the features obtained from a DataBinding that may be shown to the user, such as a data base column or an XML element or attribute. A feature is represented using a UML::StructuralFeature.

Association Ends

- featureConcept [1]: FeatureConcept - A FeatureConcept of the DomainConcept bound to a DataBinding to be shown to the user, such as a data base column, an XML element or attribute, or a UML class attribute.

8.4 Package Extensions

8.4.1 Class Details

Abstract: No

Generalization:

- [ViewComponent](#)

Description

A Details ViewComponent is used to display the details of a DataBinding instance. When the Details ViewComponent is associated with an Event, it means that the DataBinding instance displayed by the component may trigger the Event. The Event will in turn cause the passing of the Parameter values mapped to the DataBinding instance to a target InteractionFlowElement.

Constraints

- mustHaveOneDataBinding
self.viewComponentPart -> select(v | voclIsTypeOf(DataBinding)) -> size() = 1

8.4.2 Class Device

Abstract: No

Generalization:

- [ContextDimension](#)

Description

A Device is a ContextDimension that represents any device such as desktop, laptop, smart phone, tablet, or any other device from which the application may be accessed. A Device is associated with one or more Viewpoints (through the association from Viewpoint to Context). When the user context specifies the same device as the one specified by Device, the ContextDimension is satisfied and access is granted to the Viewpoint elements.

8.4.3 Class Field

Abstract: Yes

Generalization:

- [ViewComponentPart](#)
- Parameter

Description

A Field is a value-type pair whose value may be displayed to the user or serves as a means for capturing input from the user. Fields also behave as Parameters for passing their values to and from other InteractionFlowElements. There are two kinds of fields, SimpleFields and SelectionFields.

8.4.4 Class Form

Abstract: No

Generalization:

- [ViewComponent](#)

Description

The Form ViewComponent represents input forms where user can submit information through Fields (SimpleFields or SelectionFields). It comprises at least one Field and typically at least one OnSubmitEvent.

Constraints

- mustHaveAtLeastOneField
self.viewComponentPart -> select(v | v.oclIsTypeOf(Field)) -> notEmpty()

8.4.5 Class List

Abstract: No

Generalization:

- [ViewComponent](#)

Description

The List ViewComponent is used to display a list of DataBinding instances. When the List ViewComponent is associated with an Event, it means that each DataBinding instance displayed by the component may trigger the Event. The Event will in turn cause the passing of the Parameter values mapped to the DataBinding instance to a target InteractionFlowElement.

Constraints

- mustHaveOneDataBinding
self.viewComponentPart -> select(v | v.oclIsTypeOf(DataBinding)) -> size() = 1

Association Ends

- selectEvent [0..*]: OnSelectEvent - Events that represent the selection of a DataBinding instance of the List ViewComponent and the passing of the value as a Parameter.

8.4.6 Class LandingEvent

Abstract: No

Generalization:

- Catching[Event](#)

Description

A LandingEvent is the destination of a JumpEvent.

Association Ends

- jumpingEvents [0..*]: [JumpEvent](#) - Reference to the JumpEvents targeting the current LandingEvent.

8.4.7 Class JumpEvent

Abstract: No

Generalization:

- [ThrowingEvent](#)

Description

- A JumpEvent is a ThrowingEvent that, when launched, redirects the NavigationFlow entering the event to a referenced LandingEvent.

Association Ends

- landingEvent [0..1]: [LandingEvent](#) - Reference to the LandingEvent targeted by the JumpEvent.

8.4.8 Class Menu

Abstract: No

Generalization:

- [ViewContainer](#)

Description

A Menu is a special kind of ViewContainer used to model the concept of a menu of options in IFML. It cannot contain ViewComponents or sub-ViewContainers.

8.4.9 Class OnLoadEvent

Abstract: No

Generalization:

- [SystemEvent](#)

Description

An OnLoadEvent is triggered by the system when a ViewElement is completely computed and rendered.

8.4.10 Class OnSelectEvent

Abstract: No

Generalization:

- [ViewElementEvent](#)

Description

An OnSelectEvent is a kind of Event that, when triggered, results in a selected value being passed as a Parameter to the target InteractionFlowElement of its associated NavigationFlow.

8.4.11 Class OnSubmitEvent

Abstract: No

Generalization:

- [ViewElementEvent](#)

Description

An OnSubmitEvent triggers the Parameter passing of a ViewComponent to the target ViewElement or Action of its corresponding NavigationFlow. An OnSubmitEvent is typically found in Form ViewComponents.

8.4.12 Class Position

Abstract: No

Generalization:

- [ContextDimension](#)

Description

A Position is a ContextDimension representing the location and orientation of a device from which the application is accessed. A Position is associated with one or more ViewPoints (through the association between ViewPoint and Context). When the user context indicates having reached the location or orientation described by a Position, the ContextDimension is satisfied and access is granted to the ViewPoint elements and presented to the user.

8.4.13 Class SelectionField

Abstract: No

Generalization:

- [Field](#)

Description

A SelectionField is a kind of Field that enables the selection of one or more values from the predefined set of values given in its Slots.

Attributes

- isMultiSelection: Boolean - If true, the SelectionField allows the selection of multiple values.

8.4.14 Class SetContextEvent

Abstract: No

Generalization:

- [ThrowingEvent](#)

Description

A SetContextEvent is launched every time a ContextVariable is set or assigned a new value.

8.4.15 Class SimpleField

Abstract: No

Generalization:

- [Field](#)

Description

A SimpleField is a kind of Field that displays a value or captures a textual input from the user. A SimpleField also behaves as a Parameter, so that its value may be passed to other ViewElements or Actions.

8.4.16 Class Slot

Abstract: No

Generalization:

- [ViewComponentPart](#)
- [Parameter](#)

Description

A Slot is a value placeholder for a Field. When the Field is a SelectionField, its associated Slots contain the available selection options and the selected one. When the Field is a SimpleField, the Slot contains the Field value. A Slot value of a SimpleField and the Slots corresponding to the selected options of SelectionFields also act as Parameters in order to be passed to other ViewElements or Actions when an Event is triggered.

8.4.17 Class UserRole

Abstract: No

Generalization:

- [ContextDimension](#)

Description

A UserRole is a ContextDimension that represents a role played by a human user or external system that accesses the application through its user interface. A UserRole is associated with one or more ViewPoints (through the association between ViewPoint and Context). When the user context has the same user role as the one specified by the UserRole, the ContextDimension is satisfied and access is granted to the ViewPoint elements.

8.4.18 Class ValidationRule

Abstract: No

Generalization:

- [Constraint](#)

Description

A ValidationRule is a Constraint, which, when evaluated, determines if the content of a Field or group of Fields is valid or not.

8.4.19 Class Window

Abstract: No

Generalization:

- [ViewContainer](#)

Description

A Window is a special kind of ViewContainer used to model the concept of a window in IFML.

Attributes

- isNewWindow: Boolean - If true, the container will be opened as a new window.
- isModal: Boolean - If true, the window will be rendered as a modal window.

9 IFML Execution Semantics

9.1 Introduction

This clause specifies the execution semantics of IFML. The purpose is to define when and how to compute the values to be shown to the user, based on an IFMLModel. A few aspects affect the execution semantics:

1. Computation of triggering events
2. Parameter propagation
3. Navigation history preservation

9.2 Relevant Aspects for IFML Execution Semantics

9.2.1 Triggering Events

The content of a ViewContainer must be (partially or completely) computed when the following *events* arise:

1. *Inter-container navigation flow traversal*: The container is entered through a NavigationFlow originated by an Event in another container.
2. *Intra-container navigation flow traversal*: The user produces an Event inside a container that triggers the navigation of a flow targeting an Element in the same top-level ViewContainer (e.g., Window). Firing the navigation may have side effects on the content of the currently visualized Elements (e.g., it may modify content currently shown to the user) and may invalidate (partially or totally) the information used to compute the container.

9.2.2 Parameter Propagation

A ViewContainer typically contains several pieces of related information. This corresponds to having several ViewComponents linked in a network topology through NavigationFlows and DataFlows. Information may be propagated from one ViewComponent to other ViewComponents through ParameterBindings. Actual propagation depends on the Events that trigger the flows.

Conflicts may arise in the propagation of Parameters. A *conflict* arises when a ViewComponent receives more than one input value for the same Parameter. This could happen due to multiple incoming flows in a ViewComponent or ViewContainer. A *conflict resolution strategy* (CRS) specifies which Parameter value is selected to compute the data content of the ViewComponent. A conforming tool shall use one of the following possible strategies:

1. *Non-deterministic choice*: One input parameter is chosen non-deterministically at run-time among the set of available inputs.
2. *With priorities*: Priorities are assigned at design-time to the incoming flows (for the ViewComponent or ViewContainer), and, in case of run-time conflict, the Parameter value transported by the flow with highest priority is chosen. Priorities define a total ordering on the incoming flows for the ViewComponent or ViewContainer.
3. *Mixed*: A partial order of prioritization is defined at design-time over the input flows, and, in case of run-time conflict, the Parameter values transported by the flow with highest priority is chosen. If the ViewContainer is accessed at run-time in such a way that multiple flows with highest priority are in conflict, a non-deterministic choice is taken.

9.2.3 Navigation History Preservation

When the user triggers an Event, the content of the destination ViewContainer is refreshed, in a way that may depend on the past history of the user interaction. The alternatives for re-computing a ViewContainer (or a part thereof) depends on the “degree of memory” used for computation. A conforming tool may use one of the following possible interaction history policies:

1. *Without history*: The contents of the ViewComponents are computed as if the ViewContainer was accessed for the first time. The computation without history policy may be used to “reset” and forget the choices done by the user in a container.
2. *With history*: The contents of the ViewComponents are computed based on the input history of the ViewComponents existing prior to the last navigation event.

9.3 ViewComponent Computation Process

In this sub clause we provide a brief description of an algorithm for computing the content of a generic ViewContainer, with particular attention to containers of type Window.

The computation process is performed every time an Event arises. The process tries to determine the data content of all the ViewComponents of the ViewContainer, taking into account the semantic aspects discussed in 9.2. Intuitively, the process determines at each step the set of *computable* ViewComponents, i.e., the subset of ViewComponents that receive their input Parameters and therefore can be calculated.

A ViewComponent is computable if it has no incoming InteractionFlows or if it has incoming InteractionFlows and the following conditions are satisfied:

1. The ViewComponent has not been already computed (a ViewComponent cannot be computed more than once upon the same Event).
2. All the ViewComponents from which the ViewComponent may receive Parameters have been computed already.
3. All the input Parameters needed to compute the ViewComponent have a value.

If the computation semantics of the ViewContainer is without history, only current input parameters are considered in point 3. If the computation semantics is with history, components may draw their input values either from default input Parameter values or from the past Parameter values, existing prior to the last flow navigation.

The algorithm computes the contents of the ViewComponents starting from the following input parameters: it must receive the ViewContainer to compute, the set of ViewComponents to be considered in the computation (initially all the ViewComponents of the ViewContainer), the conflict resolution strategy, the interaction history policy, the past Parameter values of all the ViewComponents prior to the last flow navigation, the destination ViewComponent of the InteractionFlow whose navigation has produced the computation event together with the past Parameters transported by the flow. The following steps of the algorithm are then carried out:

1. *Component invalidation*: If the destination of the navigated flow is a ViewComponent, all its dependent ViewComponents are invalidated. (We say that ViewComponent u1 *depends* on ViewComponent u2 if u1 can be reached through NavigationFlows from u2.)
2. *Non-invalidated component computation*: One ViewComponent at a time is computed, until all possible components are considered. At each step, if there is at least one computable ViewComponent, one of them is selected and its content is computed, based on the conflict resolution strategy, the interaction history policy, and the past Parameter values. In particular:

- If a `ViewComponent` does not depend on any other `ViewComponent`, i.e., it does not expect any input `Parameter`, it can always be computed.
- If a `ViewComponent` is the destination `ViewComponent` of the `InteractionFlow` whose navigation has produced the computation event, then the past and new values of the flow `Parameters` are used for computing the component.
- In all the other cases, the interaction history policy determines which input `Parameters` must be used. If the interaction history policy is “without history,” one of the possible current input `Parameters` is chosen, according to the conflict resolution strategy. If the interaction history policy is “with history,” the past values of the input `Parameters` are considered. If the past values are available and no newer value is available for that `Parameter`, the old value is used to instantiate the `ViewComponent`; if no past values of input `Parameter` for the component are available, one of the possible input `Parameter` values is chosen according to the conflict resolution strategy.

10 IFML Diagram Definition

10.1 Introduction

This clause specifies the metamodel for IFML Diagram Interchange (IFML DI). The IFML DI is meant to facilitate interchange of IFML diagrams between tools rather than being used for internal diagram representation by the tools.

The IFML DI metamodel, similarly to the IFML abstract syntax metamodel, is defined as a MOF-based metamodel. As such, its instances can be serialized and interchanged using XMI.

The IFML DI classes only define the visual properties used for depiction. All other properties that are required for the unambiguous depiction of IFML diagram elements are derived from the referenced IFML model elements.

Multiple depictions of a specific IFML Element in a single diagram are not allowed.

10.2 Conformance Criteria

As stated in the Diagram Definition (DD) specification, Modeling language DD enables a) **Diagram Information Interchange Conformance** and b) **Diagram Graphics Conformance**. Modeling language specifications can conform to DD in two levels by supporting either (a) only, or (a) and (b). The IFML Diagram Definition provides (a) and (b).

10.3 Architecture

The IFML language specification provides three normative artifacts at M2 (shown with shaded boxes in Figure 10.1): the abstract syntax model (IFML), the IFML diagram interchange model (IFML DI), and the mapping specification between the IFML DI and the graphics model (IFML Mapping Specification).

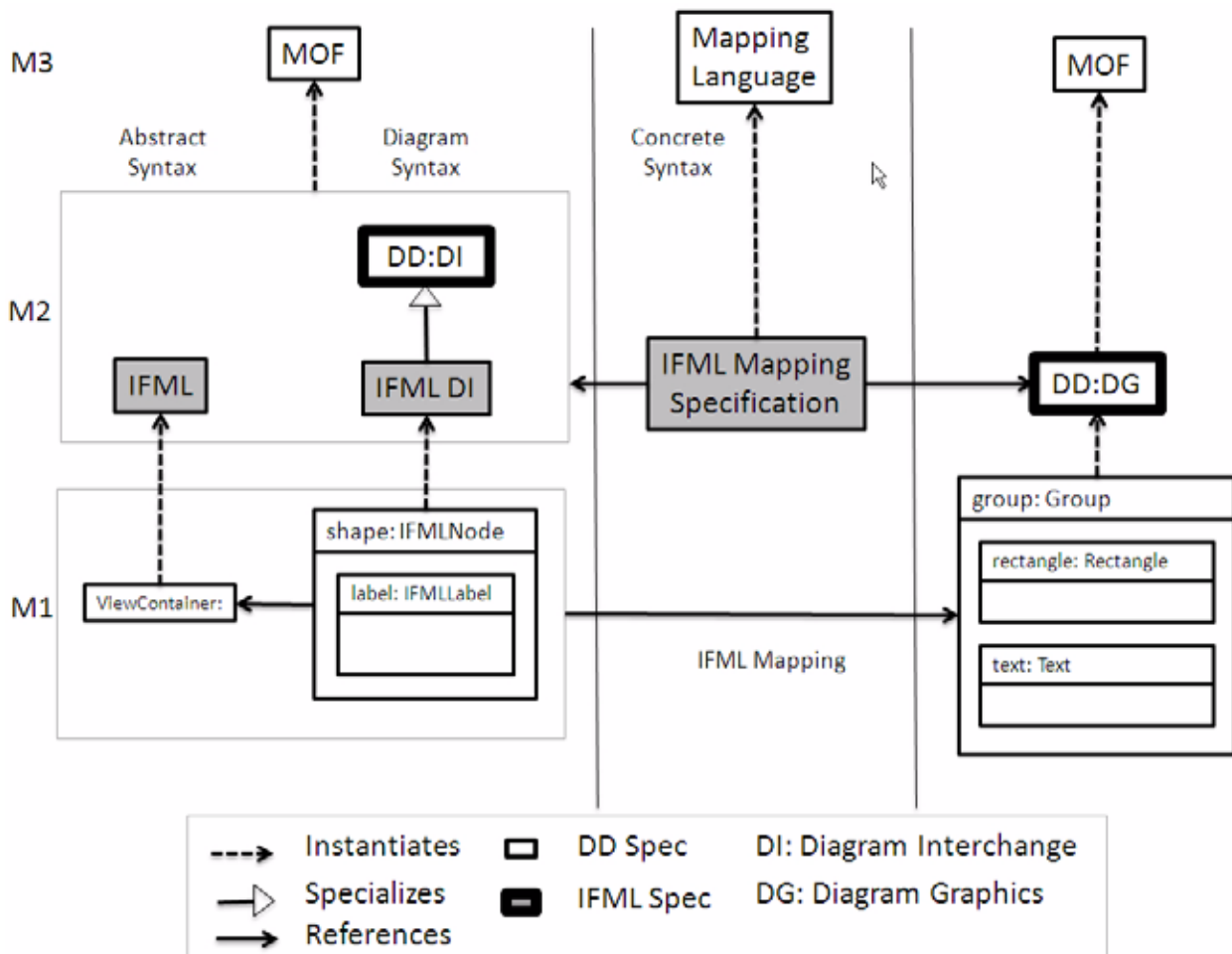

Figure 10.1 - Diagram Definition Architecture for IFML

At M1 (left), Figure 10.1 shows an instance of `IFML::Core::ViewContainer` as a model element. Next to it, on the right, the figure shows an instance of `IFMLDI::IFMLNode` referencing the `ViewContainer` element, indicating that the `ViewContainer` is depicted as a node on the diagram. The node also contains an instance of `IFMLDI::IFMLLabel` representing the textual label of the `ViewContainer` on the diagram. On the right of M1, the figure shows an instance of `DD:DG::Group` containing instances of `DD:DG::Rectangle` and `DD:DG::Text`.

`IFMLDI` specializes `DD:DI`, which specifies the graphics the user has control over, such as the position of nodes and line routing points. This information is what is captured for interchange between tools.

`DD:DG` represents the graphics that the user has no control over, such as shape and line styles, because they are the same in all languages conforming to the `DD` specification. `DD:DG` is derived by executing the mapping specification, in the middle, between `IFMLDI` and `DG`.

10.4 IFML Diagram Interchange (DI) Meta-model

The IFML DI metamodel extends the DI metamodel, where appropriate. The class IFMLDiagram represents the diagram, which composes IFMLDiagramElements. An IFMLDiagram is an IFMLNode because it may be rendered as a figure and be connected to other figures. IFMLDiagramElements optionally reference elements of an IFML model, the latter denoted by the IFML:Core:Element class. IFMLDiagramElements that do not reference elements of an IFML model are purely notational diagram elements such as notes and the link that connects the note with the model element. IFMLDiagramElements may also be styled with instances of class IFMLStyle (e.g., font type and size).

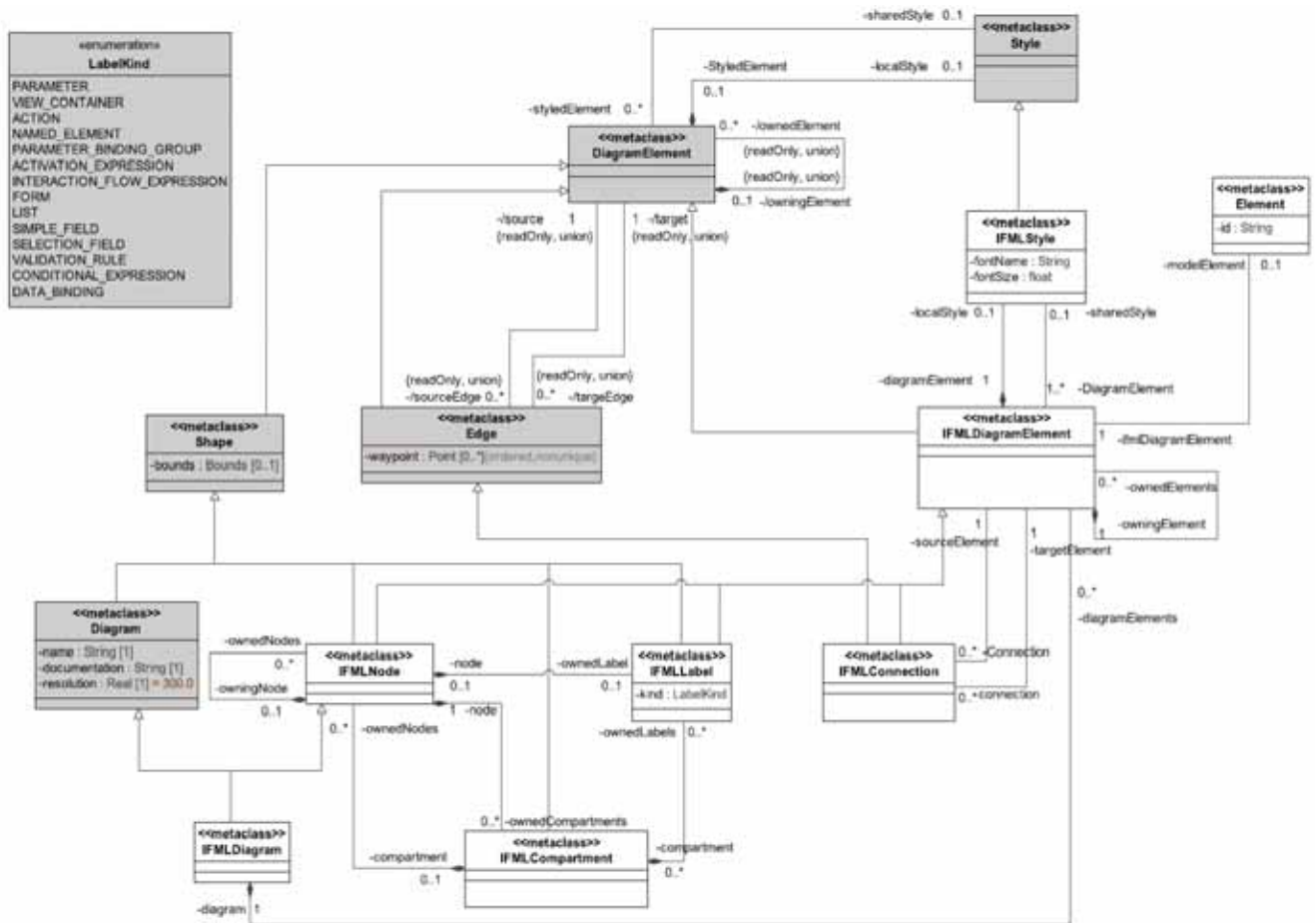

Figure 10.2 - Diagram Interchange (DI) Meta-model

Classes are defined for interchanging shapes and edges of the interaction flow diagram and the content diagram, based on the following notational patterns (see Figure 10.3):

- Pattern (a): A shape that has a label and an optional list of compartments, each of which having an optional list of labels or other shapes (e.g., the ViewContainer box, ViewComponentPart box, Form ViewComponent rounded box or the classes of the DomainModel).

- Pattern (b): A shape that has a label only (e.g., the Event ball or Action hexagon notation).
- Pattern (c): An edge that may be dashed or solid (e.g., NavigationFlows and DataFlows).

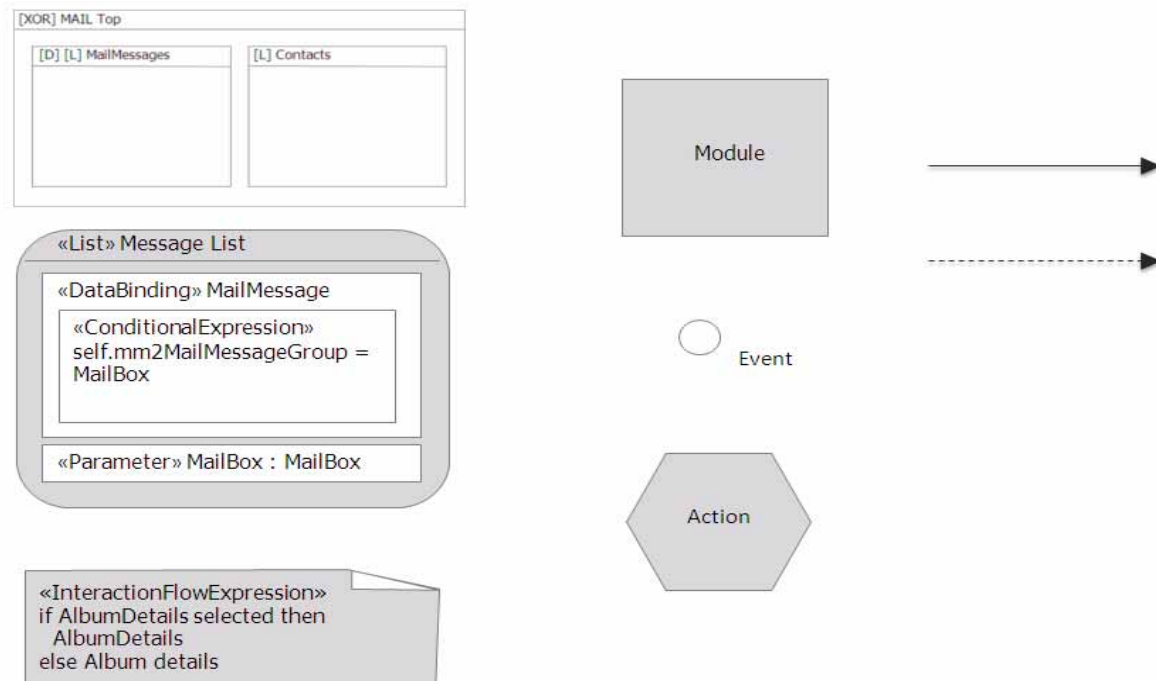

Figure 10.3 - Notational patterns

Based on these patterns, three shape classes (IFMLNode, IFMLLabel, and IFMLCompartment) and one edge class (IFMLConnection) are defined and related to realize the patterns. These classes (except IFMLCompartment) are subclasses of IFMLDiagramElement to allow them to be styled independently and to reference their own IFML Element.

Some classes have properties to disambiguate the notation and a corresponding enumeration. For instance labels may be of different kinds such as Parameter, ViewContainer, etc., which will determine how the text decoration will be rendered.

The following sub clause provides the detailed specification of the DI metamodel.

10.5 Package IFMLDI

10.5.1 Enumeration LabelKind

Description

Enumeration defining the kinds of labels, which will determine how to render the label decoration.

Literals

- action: Label of an Action.
- activationExpression: Label of an ActivationExpression.

- conditionalExpression: Label of a ConditionalExpression.
- dataBinding: Label of a DataBinding.
- form: Label of a Form.
- interactionFlowExpression: Label of an InteractionFlowExpression.
- list: Label of a List.
- namedElement: Label of any NamedElement without additional decoration.
- parameter: Label of a Parameter.
- parameterBindingGroup: Label of a ParameterBindingGroup.
- selectionField: Label of a SelectionField.
- simpleField: Label of a SimpleField.
- validationRule: Label of a ValidationRule.
- viewContainer: Label of a ViewContainer.

10.5.2 Class IFMLCompartment

Abstract: No

Generalization:

- DD::DI::Shape

Description

An IFMLCompartment is a section within an IFMLDiagramElement. An IFMLCompartment organizes the items in an IFMLDiagramElement so that it is easy to differentiate between them. IFMLCompartments may contain IFMLNodes or IFMLLabels.

Association Ends

- ownedLabels [0..*]: [IFMLLabel](#) - Composite association to the IFMLLabels owned by the compartment.
- ownedNodes [0..*]: [IFMLNode](#) - Composite association to the IFMLNodes owned by the compartment.

10.5.3 Class IFMLConnection

Abstract: No

Generalization:

- DD::DI::Edge
- [IFMLDiagramElement](#)

Description

An IFMLConnection represents a depiction of a connection between two (source and target) IFMLDiagramElements. It specializes DI::DD::Edge. IFMLConnections do not contain labels. All IFMLConnections are owned directly by an IFMLDiagram. The way-points of IFMLConnections are always relative to that diagrams's origin point and must be positive coordinates.

Association Ends

- sourceElement [1]: [IFMLDiagramElement](#) - Source IFMLDiagramElement of the connection.
- targetElement [1]: [IFMLDiagramElement](#) - Target IFMLDiagramElement of the connection.

10.5.4 Class IFMLDiagram

Abstract: No

Generalization:

- DD::DI::Diagram
- [IFMLNode](#)

Description

IFMLDiagram represents a depiction of all or part of an IFMLModel. It specializes DD::DI::Diagram and IFMLNode, since a diagram may be seen as a node as in the case of ViewPoint and Module.

Association Ends

- diagramElements [0..*]: [IFMLDiagramElement](#) – The diagram elements contained in this diagram.

10.5.5 Class IFMLDiagramElement

Abstract: No

Generalization:

- DD::DI::DiagramElement

Description

IFMLDiagramElement extends DD::DI::DiagramElement and is the supertype of all elements in diagrams, including diagrams themselves. When contained in a diagram, diagram elements are laid out relative to the diagram's origin.

An IFMLDiagramElement can be useful on its own (i.e., purely notational), or, more commonly, it is used as a depiction of another IFML Element from an IFMLModel. An IFMLDiagramElement can own other diagram elements in a graph-like hierarchy. IFMLDiagramElements can own and/or share IFMLStyle elements. Shared IFMLStyle elements are owned by other IFMLDiagramElements.

Association Ends

- localStyle [0..1]: [IFMLStyle](#) - Composite associations to IFMLStyles owned by the diagram element.
- sharedStyle [0..1]: [IFMLStyle](#) - Reference to IFMLStyles shared with other diagram elements.
- modelElement [0..1]: [ifml::core::Element](#) - Referenced Element from an IFML model.

- ownedElements [0..*]: [IFMLDiagramElement](#) - Composite association to the IFMLDiagramElements owned by the current IFMLDiagramElement.

10.5.6 Class IFMLLabel

Abstract: No

Generalization:

- DD::DI::Shape
- [IFMLDiagramElement](#)

Description

An IFMLLabel is a label that depicts textual information about an IFML Element. An IFMLLabel is always contained (but not always rendered) in an IFMLNode directly or through an IFMLCompartment. In IFML, labels are not found in IFMLConnections. IFMLLabels may derive the textual information to be depicted from a referenced IFML model Element that contains the property with the label text.

Attributes

- kind: LabelKind - Determines to what kind of Element the IFMLLabel corresponds, e.g., label of a Parameter, a ViewContainer, an Action, etc.

10.5.7 Class IFMLNode

Abstract: No

Generalization:

- DD::DI::Shape
- [IFMLDiagramElement](#)

Description

An IFMLNode represents a figure with bounds that is laid out relative to the origin of the diagram. Note that the bounds' x and y coordinates are the position of the upper left corner of the node (relative to the upper left corner of the diagram). IFMLNodes may contain IFMLCompartments and other IFMLNodes and may be connected by IFMLConnections.

Association Ends

- ownedCompartment [0..*]: [IFMLCompartment](#) - Composite associations to the IFMLCompartments owned by the node.
- ownedLabel [0..1]: [IFMLLabel](#) - Composite association to the label owned by the node.
- ownedNodes [0..*]: [IFMLNode](#) - Nested nodes of the current node. This relation is only valid if the nested node is fixed to the parent node side.

10.5.8 Class IFMLStyle

Abstract: No

Generalization:

- DD::DI::Style

Description

An IFMLStyle represents appearance options for IFMLDiagramElements. One or more elements may reference the same IFMLStyle element, which must be owned by an IFMLDiagramElement.

Attributes

- fillColor: Color - Background color of the figure.
- fontName: String - Name of the font used by the styled IFMLDiagramElement
- fontSize: Real - Size of the font used by the styled IFMLDiagramElement

10.6 IFML DI to DG Mapping Specification

The DD architecture expects language specifications to define mappings between interchanged and non-interchanged graphical information, but does not restrict how it is done. The IFML DI to DG mapping is shown in Figure 10.1 by a shaded box labeled “IFML Mapping Specification” in the middle section and is accomplished in this specification by means of the following QVT mapping.

```

1 transformation IFMLDitoDG(in ifmldi: IFMLDI, in ifml: IFML, out DG)
2
3 main() {
4   ifmldi.objectsOfType(IFMLDiagram)->map toGraphics();
5 }
6
7 mapping IFMLDiagram::toGraphics(): Canvas {
8   member += self.diagramElements->map toGraphics();
9 }
10
11 mapping IFMLDiagramElement::toGraphics(): Group {
12   localStyle := copyStyle(self.localStyle);
13   sharedStyle := copyStyle(self.sharedStyle);
14 }
15
16 mapping IFMLNode::toGraphics(): Group inherits IFMLDiagramElement::toGraphics() {
17   member += self.modelElement.map toGraphics(self);
18   member += self.ownedCompartments->map toGraphics();
19   member += self.ownedLabel.map toGraphics();
20 }
21
22 mapping IFMLLabel::toGraphics(): Text inherits IFMLDiagramElement::toGraphics() {
23   var e := self.modelElement;
24   bounds := self.bounds;
25   data := switch {
26     case (self.kind = LabelKind::NAMED_ELEMENT)
27       e.name;
28     case (self.kind = LabelKind::VIEW_CONTAINER)
29       e.oclcAsType(ViewContainer).getLabelText();
30     case (self.kind = LabelKind::ACTION)
31       e.oclcAsType(Action).getLabelText();
32     case (self.kind = LabelKind::PARAMETER)
33       «Parameter» " + e.name + ": " + e.type.name;
34     case (self.kind = LabelKind::FORM)
35       «Form» " + e.name;
36     case (self.kind = LabelKind::LIST)
37       «List» " + e.name;
38     case (self.kind = LabelKind::SIMPLE_FIELD)
39       «SimpleField» " + e.name;
40     case (self.kind = LabelKind::SELECTION_FIELD)
41       «SelectionField» " + e.name;
42     case (self.kind = LabelKind::PARAMETER_BINDING_GROUP)
43       «ParameterBindingGroup»;
44     case (self.kind = LabelKind::ACTIVATION_EXPRESSION)
45       «ActivationExpression»;
46     case (self.kind = LabelKind::INTERACTION_FLOW_EXPRESSION)
47       «InteractionFlowExpression»;
48     case (self.kind = LabelKind::VALIDATION_RULE)
49       «ValidationRule»;
50     case (self.kind = LabelKind::CONDITIONAL_EXPRESSION)
51       «ConditionalExpression»;
52     case (self.kind = LabelKind::DATA_BINDING)
53       «DataBinding»;
54     default
55       "";
56   };
57 }
58
59
60 query ViewContainer::getLabelText(): String {
61   var text := if self.oclcTypeOf(Window) and self.isModal then «Modal» endif;
62   var text := if self.oclcTypeOf(Window) and not self.isModal then «Window» endif;
63
64   text += if self.isXOR then "[XOR] " endif;
65   text += if self.isLandmark then "[L] " endif;
66   text += if self.isDefault then "[D] " endif;
67
68 }
69

```

```

70     return text + self.name;
71 }
72
73
74 mapping Element::toGraphics(n: IFMLNode): GraphicalElement
75 disjuncts ViewContainer::toRectangle, ViewComponent::toRectangle,
76           Module::toRectangle, ViewComponentPart::toRectangle, Event::toCircle,
77           Action::toPolygon, ViewPoint::toPolygon, ModuleDefinition::toRectangle,
78           Port::toRectangle, PortDefinition::toRectangle, ModulePackage::toRectangle {
79 }
80
81 mapping ViewContainer::toRectangle(n: IFMLNode): Rectangle {
82     bounds := n.bounds;
83 }
84
85 mapping ViewComponent::toRectangle(n: IFMLNode): Rectangle {
86     bounds := n.bounds;
87     cornerRadius := 15;
88 }
89
90 mapping Module::toRectangle(n: IFMLNode): Rectangle {
91     bounds := n.bounds;
92 }
93
94 mapping ModuleDefinition::toRectangle(n: IFMLNode): Rectangle {
95     bounds := n.bounds;
96 }
97
98 mapping PortDefinition::toRectangle(n: IFMLNode): Rectangle {
99     bounds := n.bounds;
100 }
101
102 mapping Port::toRectangle(n: IFMLNode): Rectangle {
103     bounds := n.bounds;
104 }
105
106 mapping ModulePackage::toRectangle(n: IFMLNode): Rectangle {
107     bounds := n.bounds;
108 }
109
110 mapping ViewComponentPart::toRectangle(n: IFMLNode): Rectangle {
111     bounds := n.bounds;
112 }
113
114 mapping Event::toCircle(n: IFMLNode): Circle {
115     var b := n.bounds;
116     center := object Point {b.x + b.width / 2; b.y + b.height / 2};
117     radius := if b.width < b.height then
118         b.width / 2
119     else
120         b.height / 2
121     endif;
122 }
123
124 mapping Action::toPolygon(n: IFMLNode): Polygon {
125     var b := n.bounds;
126     point += object Point {b.width * (1/4); y := 0};
127     point += object Point {b.width * (3/4); y := 0};
128     point += object Point {b.width; b.height * (1/4)};
129     point += object Point {b.width; b.height * (3/4)};
130     point += object Point {b.width * (3/4); b.height};
131     point += object Point {b.width * (1/4); b.height};
132     point += object Point {0; b.height * (3/4)};
133     point += object Point {0; b.height * (1/4)};
134 }
135
136 mapping ViewPoint::toPolygon(n: IFMLNode): Polygon {
137     var b := n.bounds;

```

```

138     point += object Point {b.width * (1/2); y := 0};
139     point += object Point {b.width; b.height};
140     point += object Point {0; b.height};
141   }
142
143   mapping ParameterBindingGroup::toPolygon(n: IFMLNode): Polygon {
144     var b := n.bounds;
145     point += object Point {x:=0,y:=0};
146     point += object Point {b.width*3/4,y:=0};
147     point += object Point {b.width,b.height};
148     point += object Point {b.width*1/4,b.height};
149   }
150
151   mapping IFMLCompartment::toGraphics(): Group {
152     member += object Rectangle {bounds:= self.bounds};
153     member += self.ownedNodes.map toGraphics();
154     member += self.ownedLabels.map toGraphics();
155   }
156
157   mapping IFMLConnection::toGraphics(): Group inherits
158     IFMLDiagramElement::toGraphics() {
159     member += self.modelElement.map toGraphics(self);
160   }
161
162   mapping Element::toGraphics(c: IFMLConnection): GraphicalElement
163     disjuncts NavigationFlow::toPolyline, DataFlow::toPolyline {
164   }
165
166
167   mapping NavigationFlow::toPolyline(c: IFMLConnection): Polyline {
168     point := c.waypoint;
169     sharedStyle := solidStyleProp;
170     endMarker := arrowMarkerProp;
171   }
172
173   property solidStyleProp = object DG::Style {
174     strokeDashLength := Sequence{};
175   }
176
177   property arrowMarkerProp = object Marker {
178     size := object Dimension {width := 2; height := 2};
179     reference := object Point {x := 2; y := 1};
180     member += object Polygon {
181       point += object Point {x := 0; y := 0};
182       point += object Point {x := 2; y := 1};
183       point += object Point {x := 0; y := 2};
184     }
185   }
186
187   mapping DataFlow::toPolyline(c: IFMLConnection): Polyline {
188     point := c.waypoint;
189     sharedStyle := dashedStyleProp;
190     endMarker := arrowMarkerProp;
191   }
192
193   property dashedStyleProp = object DG::Style {
194     strokeDashLength := Sequence{2, 2};
195   }
196
197   helper copyStyle(s: IFMLStyle): DG::Style {
198     fontName := s.fontName;
199     fontSize := s.fontSize;
200     fillColor := s.fillColor;
201   }
202
203
204
205

```

11 UML Profile for IFML

11.1 Overview

The UML Profile for IFML enables the use of UML for representing IFML models. The purpose of the profile is to extend the UML metamodel by customizing it with specific IFML constructs.

The UML Profile for IFML is based on the use of UML components (both basic components and packaging components), classes and other concepts.

Components may form hierarchical structures (a packaging component that owns other components) and they may be connected with dependencies, either through explicit interfaces or directly.

Components may be shown in a structural UML diagram, such as a component diagram.

Their dynamic behavior may be shown in interaction diagrams, such as a communication diagram. The behavior of components may also be described in a statechart diagram or in an activity diagram. Examples of these diagrams are not shown here.

11.2 The IFML Profile of UML

The UML Profile for IFML consists of the stereotypes defined in this sub clause. These stereotypes are shown in a set of UML diagrams below, along with a table for each diagram giving the specification of the depicted stereotypes.

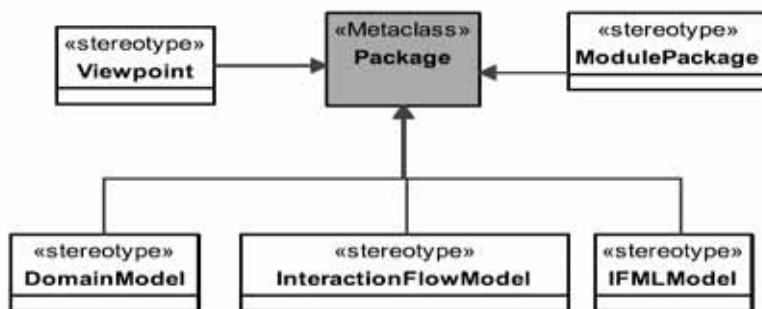

Figure 11.1 - Package stereotypes

Table 11.1 - Package stereotypes

Stereotype	UML Metaclass	Tagged Values	Constraints	Icon
«DomainModel»	UML::Kernel::Package			
«IFMLModel»	UML::Kernel::Package			
«InteractionFlowModel»	UML::Kernel::Package			
«ModulePackage»	UML::Kernel::Package			
«Viewpoint»	UML::Kernel::Package			



Figure 11.2 - Annotation stereotype

Table 11.2 - Annotation stereotype

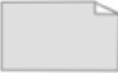
Stereotype	UML Metaclass	Tagged Values	Constraints	Icon
«Annotation»	UML::Kernel::Comment			

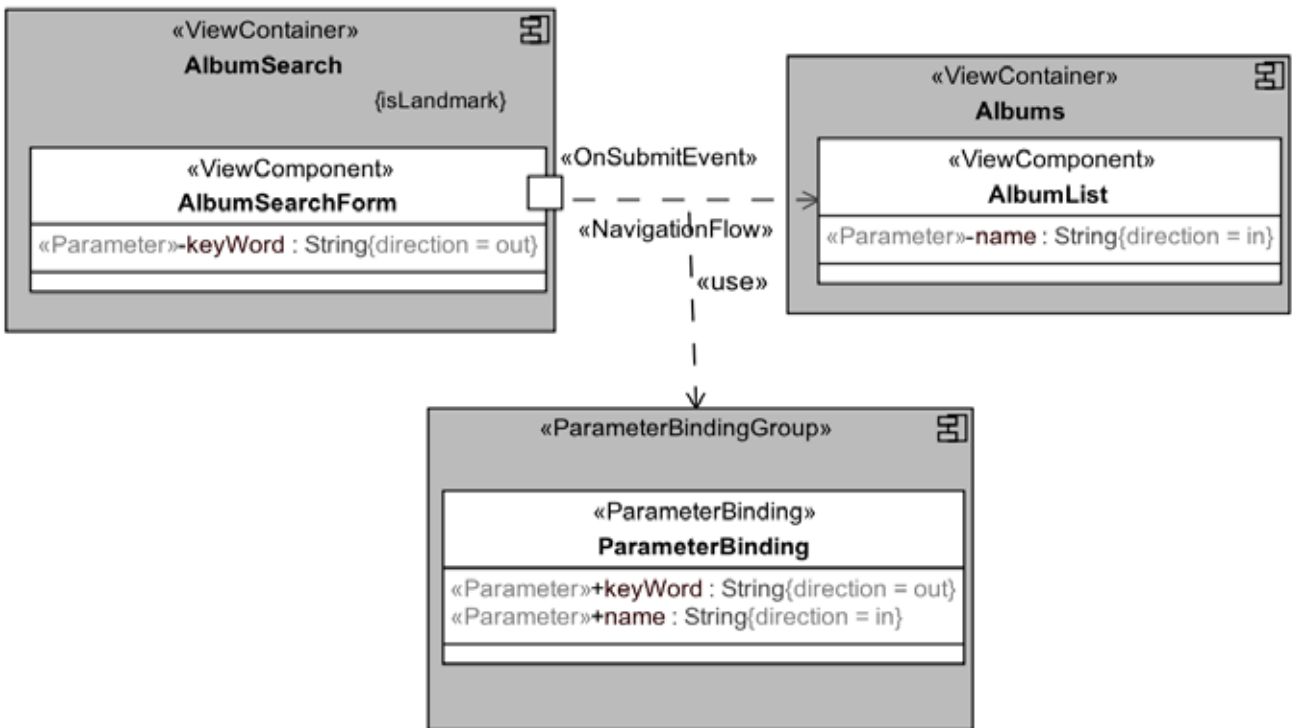

Figure 11.3 - ViewContainer, ParameterBindingGroup, and Module Definition stereotypes

Table 11.3 - ViewContainer, ParameterBindingGroup, and ModuleDefinition stereotypes



Stereotype	UML Metaclass	Tagged Values	Constraints	Icon
«ModuleDefinition»	UML::Components:: BasicComponents:: Component		It must contain at least 1 InteractionFlow- ModelElement	
«ParameterBindingGroup»	UML::Components:: BasicComponents:: Component			
«ViewContainer»	UML::Components:: BasicComponents:: Component	isLandMark: Boolean isDefault: Boolean isXor: Boolean		

Table 11.4 - ViewContainer and ModuleDefinition stereotypes (extension)

Stereotype	UML Metaclass	Tagged Values	Constraints	Icon
«Menu»	UML::Components:: BasicComponents:: Component			
«Window»	UML::Components:: BasicComponents:: Component	isNewWindow: Boolean isModal: Boolean		

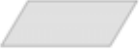
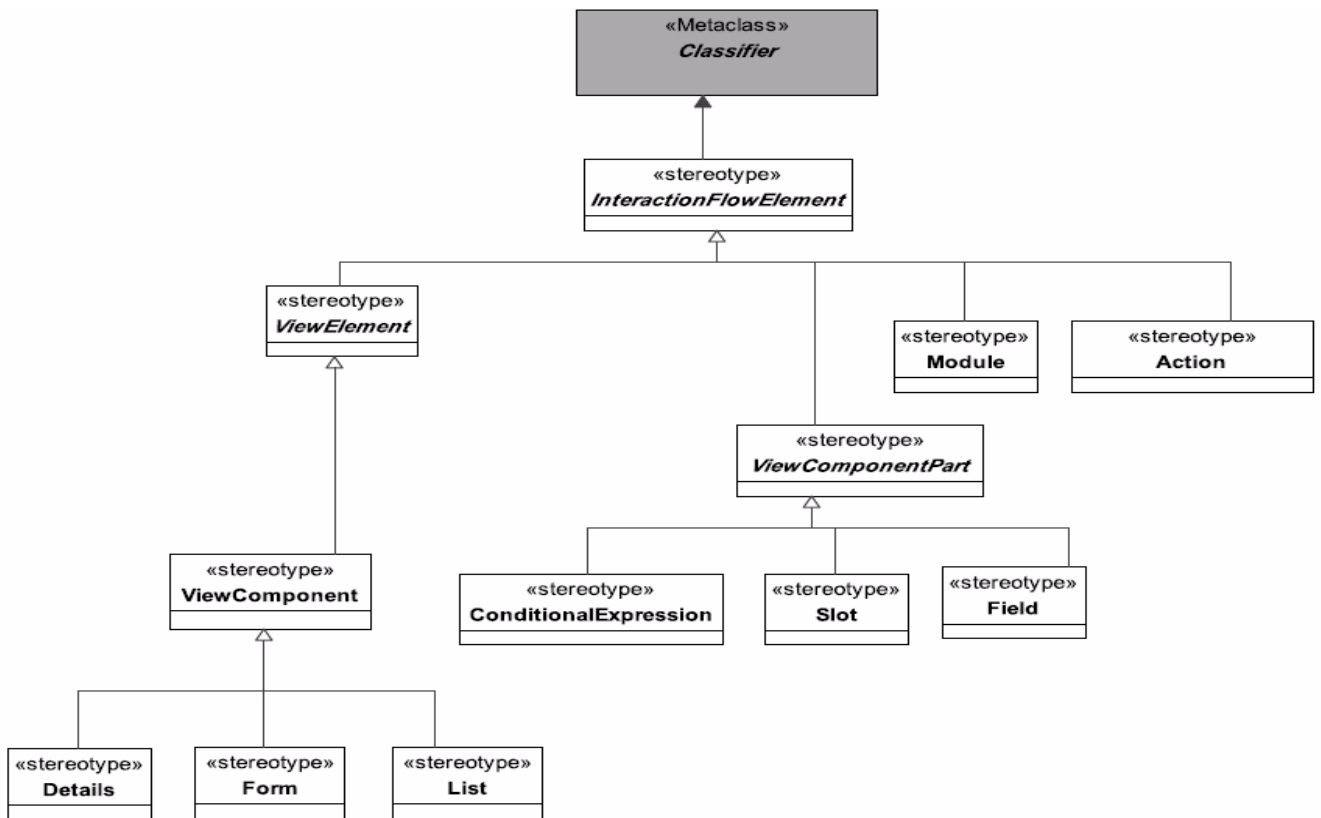

Figure 11.4 - InteractionFlowElements stereotypes (except events)

Table 11.5 - InteractionFlowElements stereotypes (except events)





Stereotype	UML Metaclass	Tagged Values	Constraints	Icon
«ViewElement»	UML::Kernel:: Classifier			
«InteractionFlowElement»	UML::Kernel:: Classifier			
«Module»	UML::Kernel:: Classifier			
«ViewComponent»	UML::Kernel:: Classifier			
«ViewComponentPart»	UML::Kernel::Classifier			

Table 11.6 - InteractionFlowElements stereotypes (except events) (extensions)

Stereotype	UML Metaclass	Tagged Values	Constraints	Icon
«List»	UML::Kernel::Classifier			
«Form»	UML::Kernel::Classifier			
«Details»	UML::Kernel::Classifier			
«Field»	UML::Kernel::Classifier			

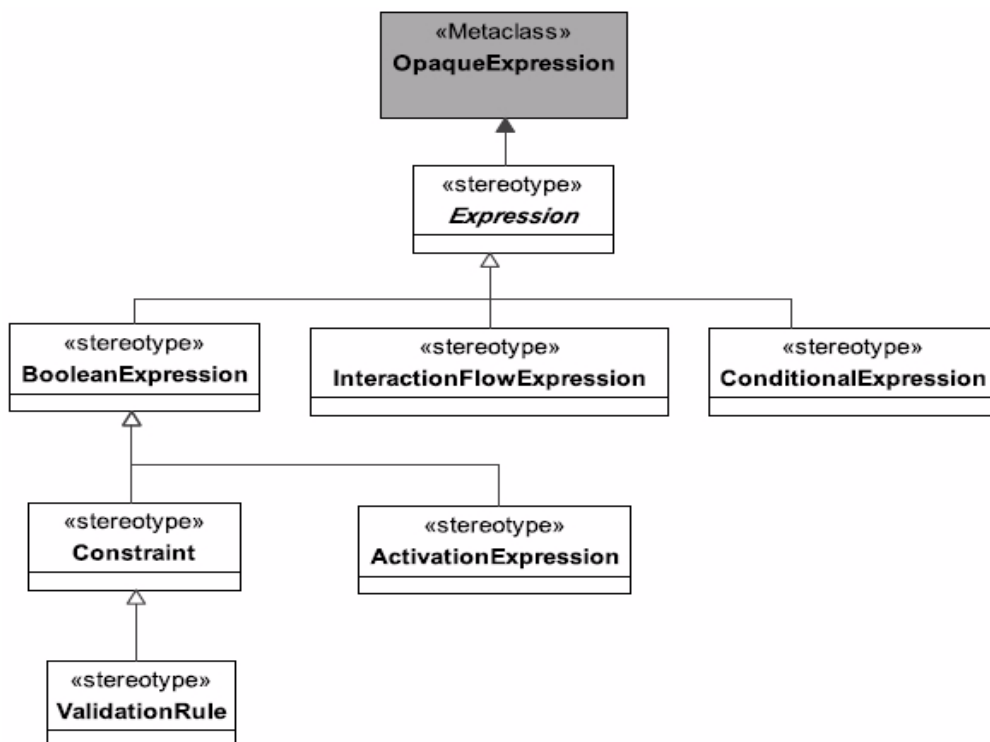



Figure 11.5 - Expressions stereotypes

Table 11.7 - Expressions stereotypes

Stereotype	UML Metaclass	Tagged Values	Constraints	Icon
«ActivationExpression»	UML::Kernel:: OpaqueExpression			
«BooleanExpression»	UML::Kernel:: OpaqueExpression			
«ConditionalExpression»	UML::Kernel:: OpaqueExpression UML::Kernel:: Classifier			
«Constraint»	UML::Kernel:: OpaqueExpression			
«Expression»	UML::Kernel:: OpaqueExpression			
«InteractionFlowExpression»	UML::Kernel:: OpaqueExpression			
«ValidationRule»	UML::Kernel:: OpaqueExpression			

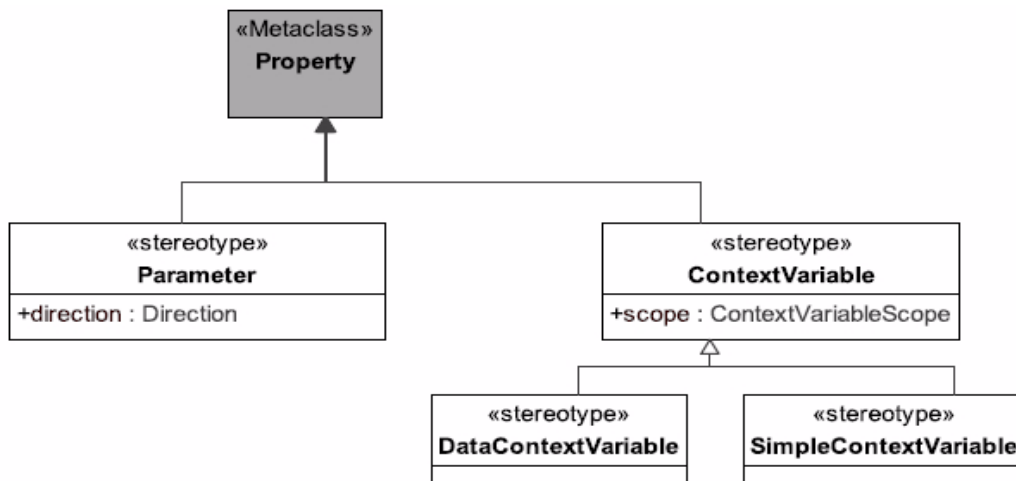

Figure 11.6 - Parameter and context variable stereotypes

Table 11.8 - Parameter and context variable stereotypes

Stereotype	UML Metaclass	Tagged Values	Constraints	Icon
«Parameter»	UML::Kernel::Property	direction: Direction		
«ContextVariable»	UML::Kernel::Property	scope: ContextVariableScope		
«SimpleContextVariable»	UML::Kernel::Property			
«DataContextVariable»	UML::Kernel::Property			

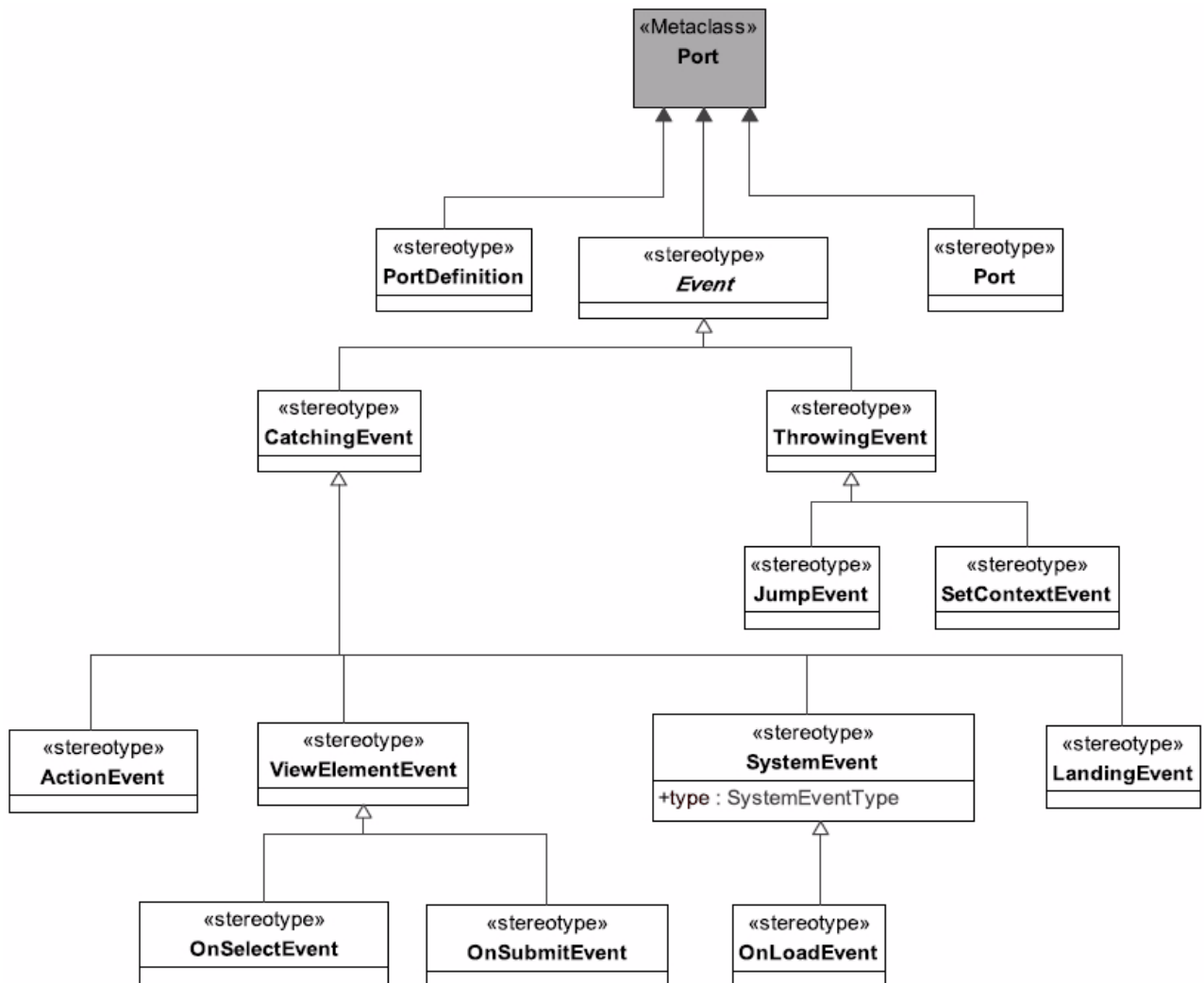

Figure 11.7 - Port and Events stereotypes

Table 11.9 - Ports and Events stereotypes















Stereotype	UML Metaclass	Tagged Values	Constraints	Icon
«ActionEvent»	UML::CompositeStructures:: Ports::Port			
«Event»	UML::CompositeStructures:: Ports::Port			
«SystemEvent»	UML::CompositeStructures:: Ports::Port	type: SystemEventType		
«CatchingEvent»	UML::CompositeStructures:: Ports::Port			
«ThrowingEvent»	UML::CompositeStructures:: Ports::Port			
«JumpEvent»	UML::CompositeStructures:: Ports::Port			
«LandingEvent»	UML::CompositeStructures:: Ports::Port			
«ViewElement Event»	UML::CompositeStructures:: Ports::Port			
«Port»	UML::CompositeStructures:: Ports::Port			
«PortDefinition»	UML::CompositeStructures:: Ports::Port			

Table 11.10 - Ports and Events stereotypes (extensions)

Stereotype	UML Metaclass	Tagged Values	Constraints	Icon
«OnSelectEvent»	UML::CompositeStructures:: Ports::Port			
«OnSubmitEvent»	UML::CompositeStructures:: Ports::Port			
«SetContextEvent»	UML::CompositeStructures:: Ports::Port			
«OnLoadEvent»	UML::CompositeStructures:: Ports::Port			

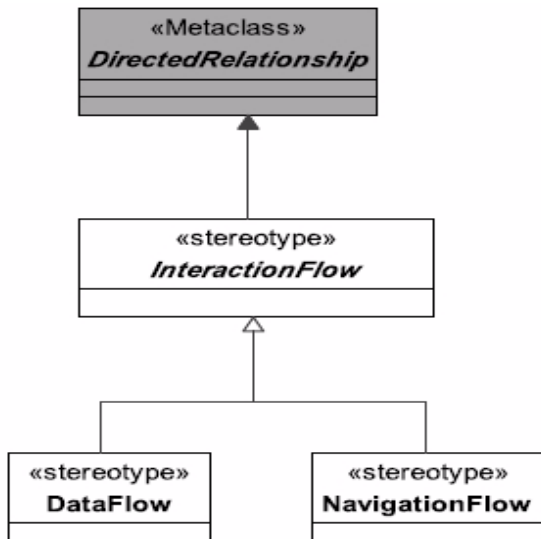



Figure 11.8 - InteractionFlow stereotypes

Table 11.11 - InteractionFlow stereotypes

Stereotype	UML Metaclass	Tagged Values	Constraints	Icon
«DataFlow»	UML::Kernel::DirectedRelationship		Must be associated with a ParameterBinding	
«InteractionFlow»	UML::Kernel::DirectedRelationship			
«NavigationFlow»	UML::Kernel::DirectedRelationship			

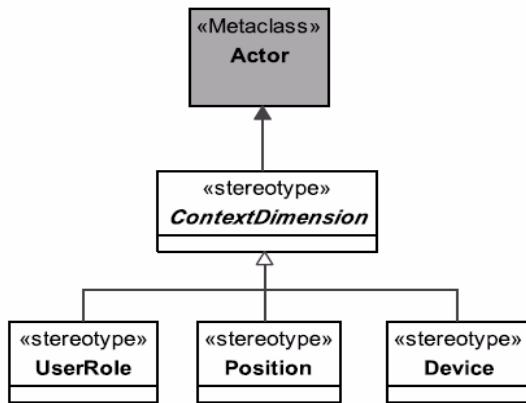





Figure 11.9 - ContextDimensions

Table 11.12 - ContextDimensions stereotypes

Stereotype	UML Metaclass	Tagged Values	Constraints	Icon
«ContextDimension»	UML::UseCases::Actor			

Table 11.13 - ContextDimensions stereotypes (extension)

Stereotype	UML Metaclass	Tagged Values	Constraints	Icon
«Device»	UML::UseCases::Actor			
«UserRole»	UML::UseCases::Actor			
«Position»	UML::UseCases::Actor			

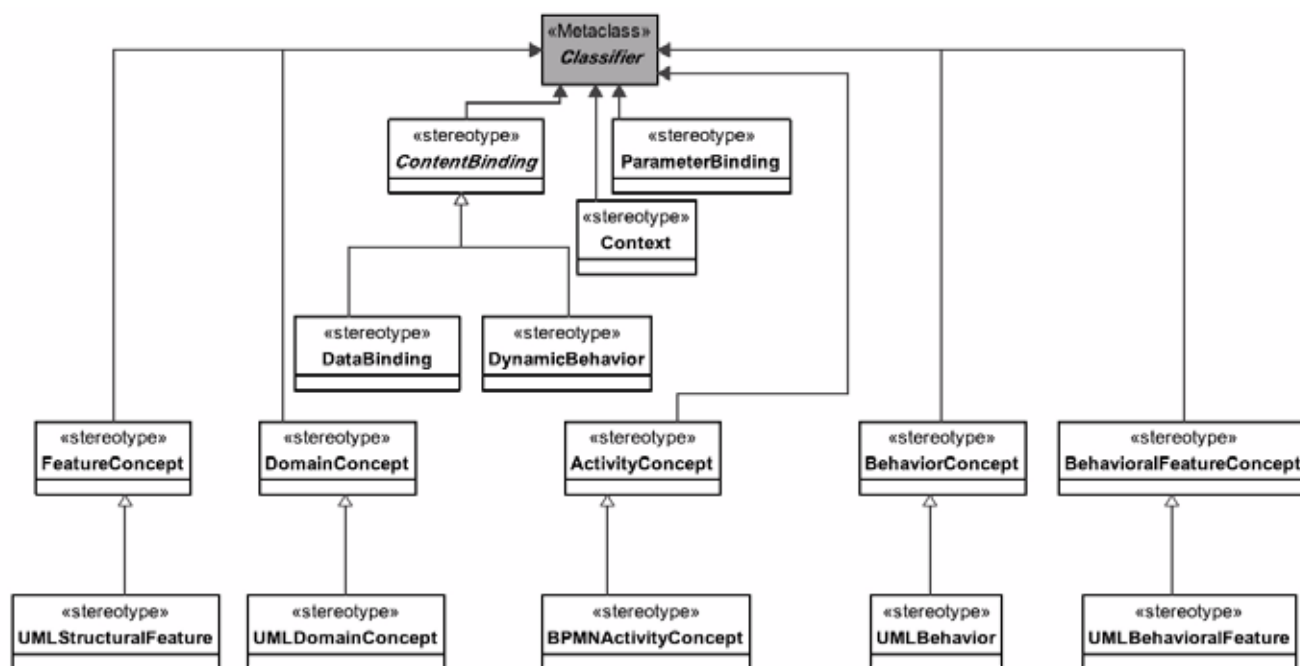





Figure 11.10 - ContentBindings, Context, and ParameterBindings stereotypes

Table 11.14 - ContentBindings, Context, and ParameterBindings stereotypes

Stereotype	UML Metaclass	Tagged Values	Constraints	Icon
«ContentBinding»	UML::Kernel::Classifier			
«Context»	UML::Kernel::Classifier			
«DataBinding»	UML::Kernel::Classifier			
«DynamicBehavior»	UML::Kernel::Classifier			
«ParameterBinding»	UML::Kernel::Classifier			
«ActivityConcept»	UML::Kernel::Classifier			
«FeatureConcept»	UML::Kernel::Classifier			
«DomainConcept»	UML::Kernel::Classifier			
«BehaviorConcept»	UML::Kernel::Classifier			
«BehavioralFeatureConcept»	UML::Kernel::Classifier			
«BPMNActivityConcept»	UML::Kernel::Classifier			
«UMLStructuralFeature»	UML::Kernel::Classifier			
«UMLDomainConcept»	UML::Kernel::Classifier			
«UMLBehavior»	UML::Kernel::Classifier			
«UMLBehavioralFeature»	UML::Kernel::Classifier			

11.3 Using IFML Stereotypes

IFML stereotypes can be user with different abstraction levels, i.e. using stereotypes that correspond to the IFML Core package, the IFML Extension package, or user provided platform-specific stereotypes.

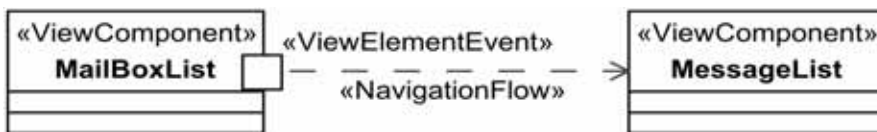

Figure 11.11 - Stereotyped UML diagram with IFML Core

For instance, for stereotyping with IFML Core concepts, classes, components and ports may be stereotyped with ViewContainer, ViewComponent, ViewComponentPart, Event, and Action concepts, and directed relationships with NavigationFlow and DataFlow concepts as shown in Figure 11.11.

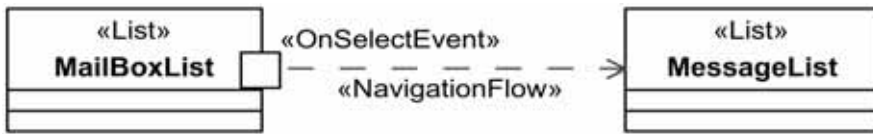

Figure 11.12 - Stereotyped UML diagram with IFML Extensions

For stereotyping with IFML Extension concepts, classes may be stereotyped as List, Details and Form concepts, and ports with events like OnSelectEvent and OnSubmitEvent as shown in Figure 11.12.

Components own (or import) classes. In Figure 11.13, ViewContainers are shown as components and contain classes stereotyped as ViewComponents.

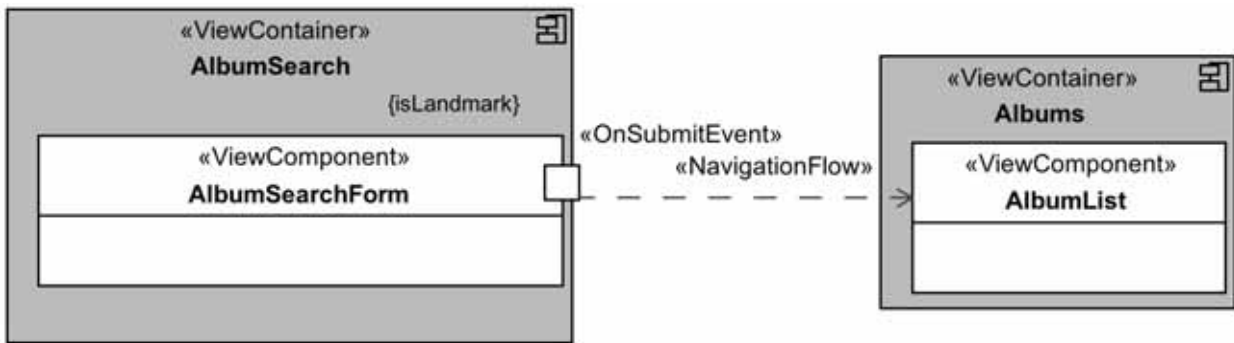

Figure 11.13 - Stereotyped UML diagram with ViewContainers containing ViewComponents

Parameters are defined as properties of the ViewComponents, with a tagged value representing their direction. ParameterBindingGroups are associated to NavigationFlows and DataFlows and contain classes stereotyped as ParameterBindings.

Figure 11.14 shows the representation of Parameters, ParameterBindingGroups, and ParameterBindings on the previous example.

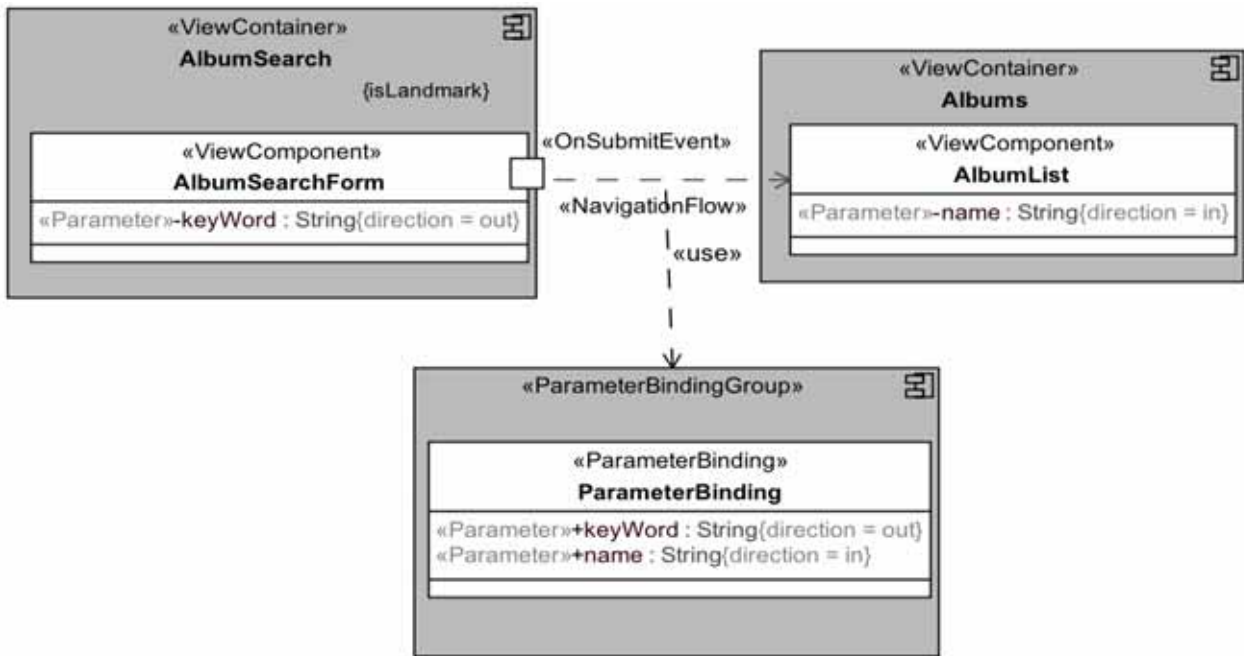

Figure 11.14 - Stereotyped UML diagram including Parameters, ParameterBindings, and ParameterBindingGroups

11.4 Profile Metamodel Mapping

Table 11.15 shows, for each metaclass from the IFML metamodel in Clause 8, the mapping to the respective stereotype of the IFML UML profile.

Table 11.15 - Profile metamodel mapping

IFML Metaclass	Stereotype
IFML::Core::Action	«Action»
IFML::Core::ActionEvent	«ActionEvent»
IFML::Core:: ActivationExpression	«ActivationExpression»
IFML::Core:: ActivityConcept	«ActivityConcept»
IFML::Core::Annotation	«Annotation»
IFML::Core:: BehaviorConcept	«BehaviorConcept»
IFML::Core:: BehavioralFeaureConcept	«BehavioralFeatureConcept»
IFML::Core::BooleanExpression	«BooleanExpression»
IFML::Core::BPMNActivityConcept	«BPMNActivityConcept»
IFML::Core::CatchingEvent	«CatchingEvent»
IFML::Core::ConditionalExpression	«ConditionalExpression»
IFML::Core::Constraint	«Constraint»

Table 11.15 - Profile metamodel mapping

IFML::Core::ContentBinding	«ContentBinding»
IFML::Core::DomainModel	«DomainModel»
IFML::Core::Context	«Context»
IFML::Core::ContextDimension	«ContextDimension»
IFML::Core::ContextVariable	«ContextVariable»
IFML::Core::DataBinding	«DataBinding»
IFML::Core::DataContextVariable	«DataContextVariable»
IFML::Core::DataFlow	«DataFlow»
IFML::Core::DomainConcept	«DomainConcept»
IFML::Core::DomainModel	«DomainModel»
IFML::Core::DynamicBehavior	«DynamicBehavior»
IFML::Core::Element	«Element»
IFML::Core::Event	«Event»
IFML::Core::Expression	«Expression»
IFML::Core::FeatureConcept	«FeatureConcept»
IFML::Core::IFMLModel	«IFMLModel»
IFML::Core::InteractionFlow	«InteractionFlow»
IFML::Core::InteractionFlowElement	«InteractionFlowElement»
IFML::Core::InteractionFlowExpression	«InteractionFlowExpression»
IFML::Core::InteractionFlowModel	«InteractionFlowModel»
IFML::Core::InteractionFlowModelElement	«InteractionFlowModelElement»
IFML::Core::Module	«Module»
IFML::Core::ModuleDefinition	«ModuleDefinition»
IFML::Core::ModulePackage	«ModulePackage»
IFML::Core::NamedElement	«NamedElement»
IFML::Core::NavigationFlow	«NavigationFlow»
IFML::Core::Parameter	«Parameter»
IFML::Core::ParameterBinding	«ParameterBinding»
IFML::Core::ParameterBindingGroup	«ParameterBindingGroup»
IFML::Core::Port	«Port»
IFML::Core::PortDefinition	«PortDefinition»
IFML::Core::SimpleContextVariable	«SimpleContextVariable»
IFML::Core::SystemEvent	«SystemEvent»
IFML::Core::ThrowingEvent	«ThrowingEvent»
IFML::Core::UMLBehavior	«UMLBehavior»
IFML::Core::UMLBehavioralFeature	«UMLBehavioralFeature»

Table 11.15 - Profile metamodel mapping

IFML::Core::UMLDomainConcept	«UMLDomainConcept»
IFML::Core::UMLStructuralFeature	«UMLStructural»
IFML::Core::ViewComponent	«ViewComponent»
IFML::Core::ViewComponentPart	«ViewComponentPart»
IFML::Core::ViewContainer	«ViewContainer»
IFML::Core::ViewElement	«ViewElement»
IFML::Core::ViewElementEvent	«ViewElementEvent»
IFML::Core::ViewPoint	«ViewPoint»
IFML::DataTypes::ParameterKind	«ParameterKind»
IFML::DataTypes::SystemEventTypeEnum	«SystemEventTypeEnum»
IFML::Extensions::Device	«Device»
IFML::Extensions::Form	«Form»
IFML::Extensions::Field	«Field»
IFML::Extensions::List	«List»
IFML::Extensions::LandingEvent	«LandingEvent»
IFML::Extensions::JumpEvent	«JumpEvent»
IFML::Extensions::Menu	«Menu»
IFML::Extensions::Details	«Details»
IFML::Extensions::Window	«Window»
IFML::Extensions::Position	«Position»
IFML::Extensions::OnLoadEvent	«OnLoadEvent»
IFML::Extensions::OnSelectEvent	«OnSelectEvent»
IFML::Extensions::SetContextEvent	«SetContextEvent»
IFML::Extensions::Slot	«Slot»
IFML::Extensions::OnSubmitEvent	«OnSubmitEvent»
IFML::Extensions::UserRole	«UserRole»
IFML::Extensions::ValidationRule	«ValidationRule»

Annex A

IFML by Example: Modeling an Email

(informative)

A.1 Introduction

This annex exemplifies the modeling construct and the expressive power of IFML by modeling a popular Internet Application specialized on email service.

A.2 The Domain Model

The email application manages mail messages and contacts of users.

A **User** possesses a set of **MailBoxes**. A **MailBox** (aka System Tag) consists of a set of **MailMessages**, **MailMessages** are organized not only in **MailBoxes** but also in user-defined clusters, called **Tags**. Therefore, **MailBoxes** and **Tags** can be seen as special cases of a common concept of **MailMessageGroup**. A user can also manage **ChatConversations**, which are composed of **ChatMessages**. A **User** is also associated with a set of **Contacts**. **Contacts** are clustered in **ContactGroups**.

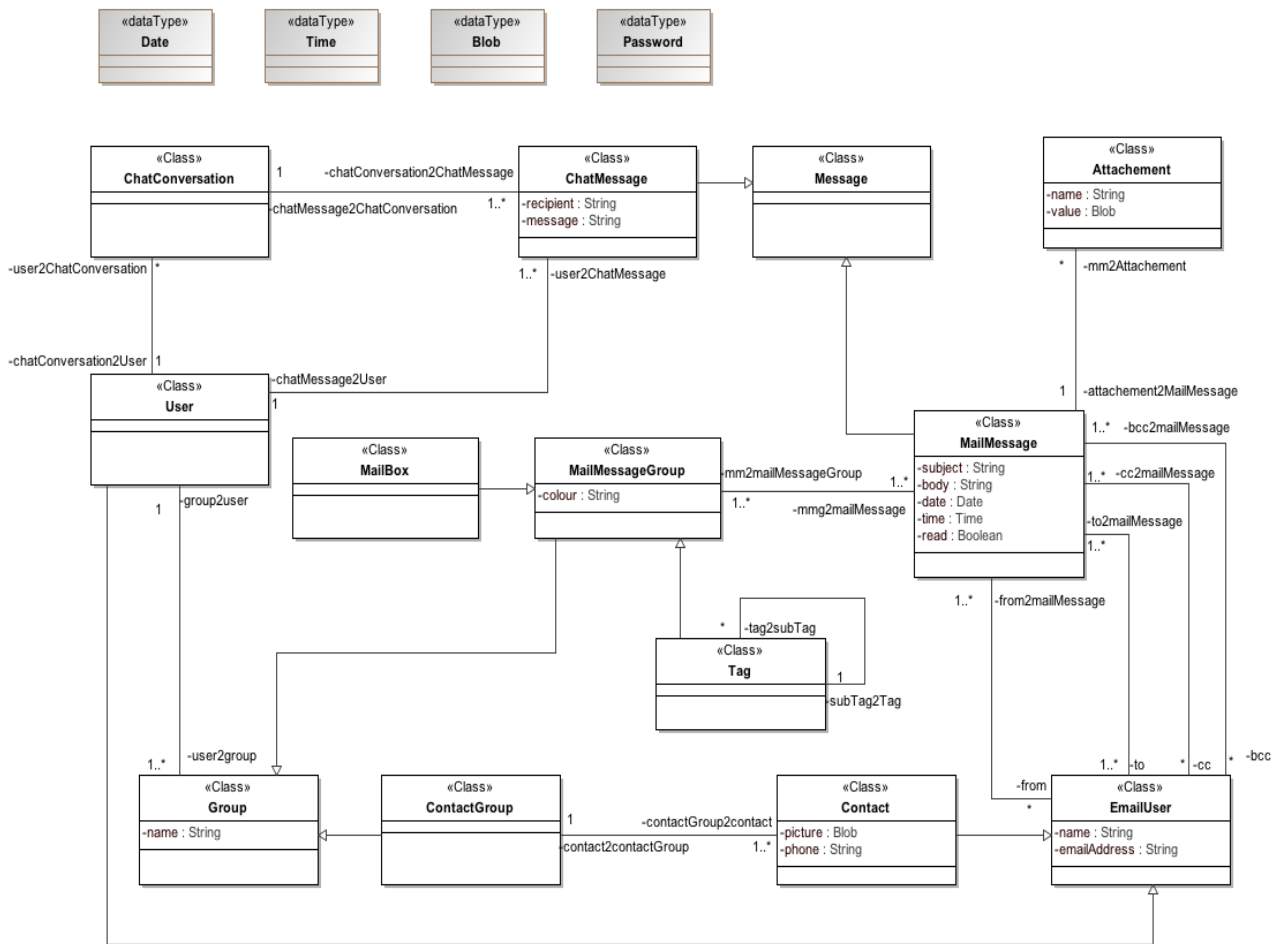

Figure A.1 - The Domain Model of the online mailing application

A.3 Model of the Interface

The email application interface consists of a top-level container, which is logically divided into two *alternative* sub-containers: one for managing *MailMessages* and one for managing *Contacts*.

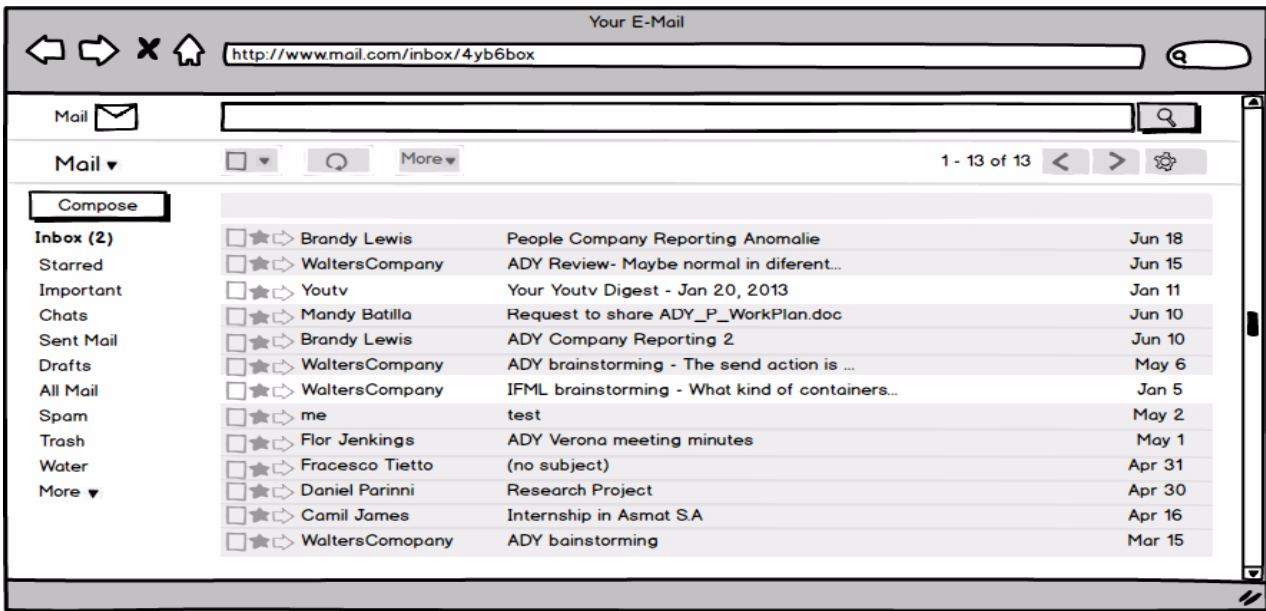

Figure A.2 - The mail application view container for MailMessages

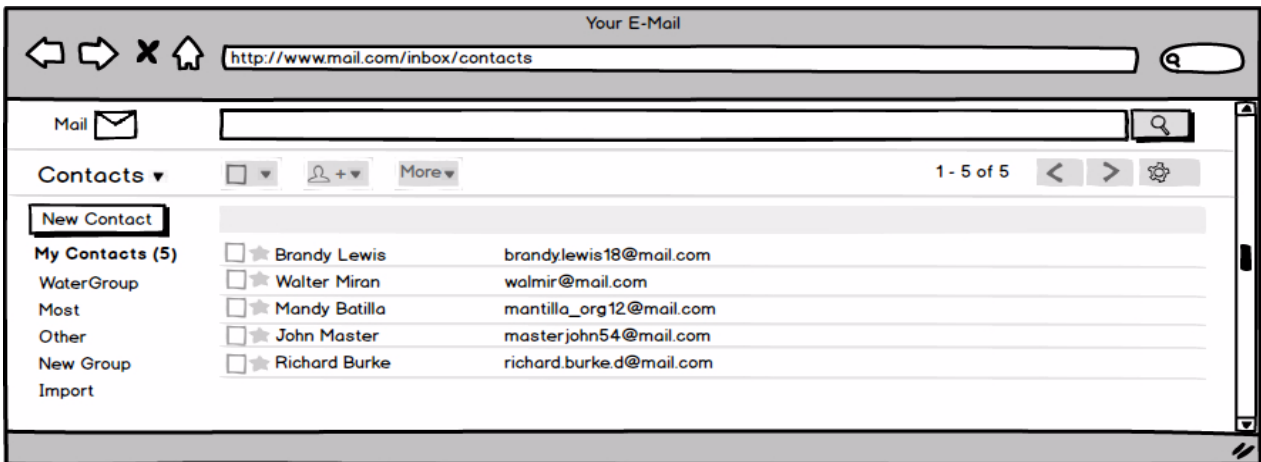

Figure A.3 - email application view container for Contacts

By default, when the application is accessed, the container for managing *MailMessages* is presented. At any moment, it is possible to Switch from the *MailMessages* to the Contacts view components, by means of a menu, shown in Figure A.4.



Figure A.4 - A menu allows one to switch from the MailMessages to the Contacts view components

The model of the top level container of the application is shown in Figure A.5.

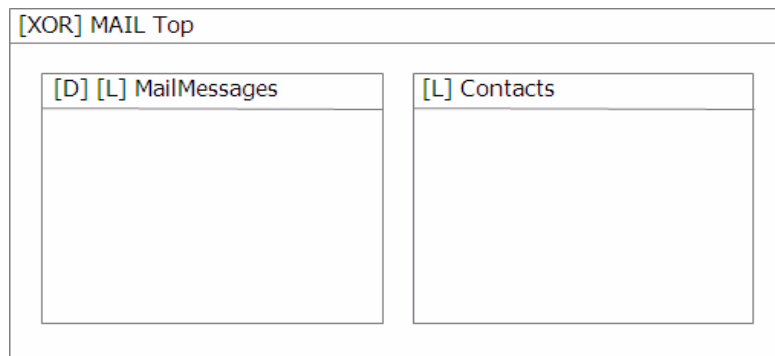

Figure A.5 - IFML model of the Top Container of the email application

Notations

1. The nesting of mutually exclusive view containers into a view container (*isXOR* property equal true) is denoted with a [XOR] icon.
2. The default view container (*isDefault* property equal true) of a set of mutually exclusive view sibling containers is denoted with a [D] icon on container.
3. The global reachability of view container from all the other sibling containers and their children sub-containers is denoted with an [L] (Landmark) icon on container.

Model usability

- The use of the [L] (Landmark) icon reduces the number of navigation events that need to be explicitly represented (otherwise one event should be necessary in all the view containers from which the target view container is reachable), resulting in simpler models.

The *MailMessages* view container comprises five main nested elements:

- a view component (*MboxList*) showing a list of *MailBoxes* and *Tags*;
- a view container (*MessageSearch*) permitting the user to input search keywords to be matched against the *MailMessages*;
- a *MailBox* view container, permitting one to access the messages of a specific *MailBox* or associated with a specific Tag and the details of a specific message;
- a *MessageWriter* view container, permitting one to access the details of a specific message;
- a *Settings* view container, permitting one to modify the settings of the email application.

The *MailBox*, *MessageWriter*, and *Settings* view containers are in alternative: only one at a time is displayed. None of these alternate view containers is the default one, because they are all accessed as a consequence of an explicit user's choice. The *MessageWriter* and *Settings* view containers are denoted as landmark, because they are reachable from all the other sibling view containers of the *MailMessages* view container. Conversely, the *MailBox* view container is not denoted as landmark, because it is accessed only by means of a specific interaction event: the selection of a *MailBox* from the *MboxList* view component.

The *MailBox* view container comprises the view component (*MessageList*) showing the *MailMessages* associated to a given *MailBox* or *Tag*. The *MboxList* allows user interaction: selecting a specific *MailBox* or *Tag* the user produces a navigation event that results in changing the content of the *MessageList*, so to display the messages of the selected *MailBox* or *Tag*. This behavior is represented in the model fragment shown in Figure A.6.

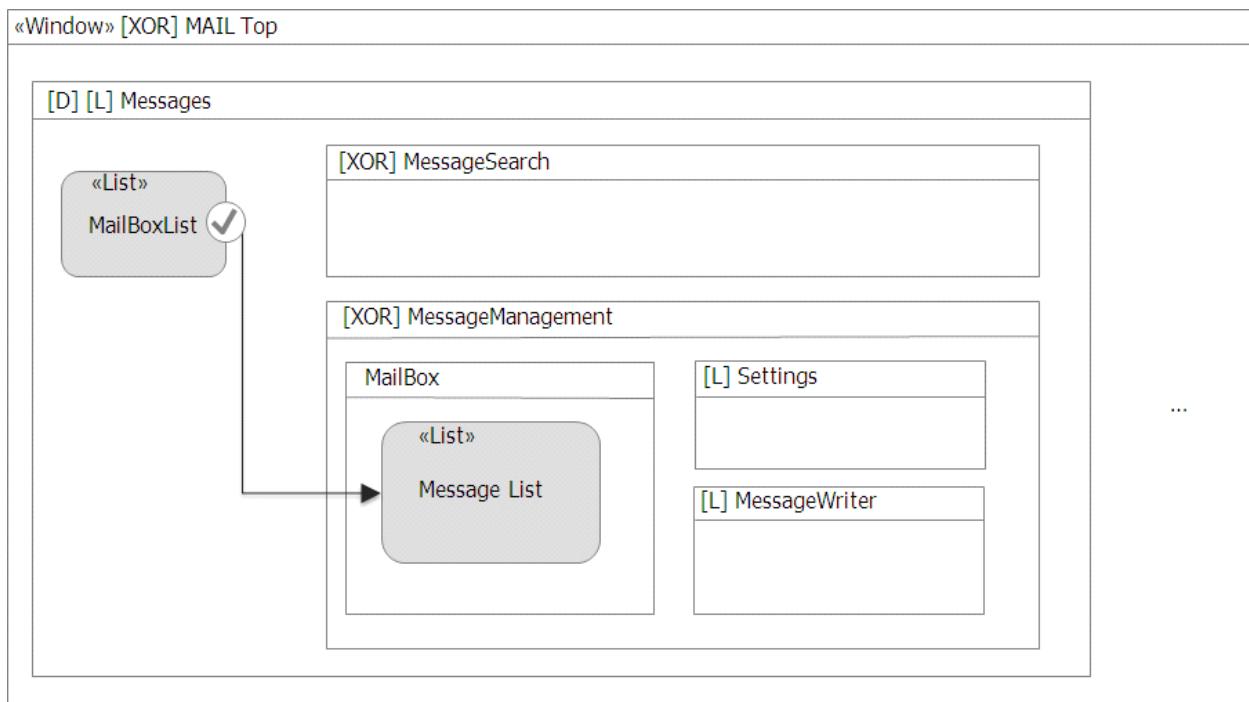

Figure A.6 - Model of the MailMessages view container: a navigation event and parameter passing flow between the MailBoxList view component and the MessageList view component denote that the user can select one mail box and view a list of its messages

Semantics

1. The *MBoxList* view component is associated with an event, denoted by a circle. A interaction flow connects the event to the target components affected by it: *MessageList*. The semantics of this pattern is that a user's interaction with the *MailBoxList* view component determines: 1) the display of the view container that comprises the *MessageList* view component (the *MailBox* XOR child of the *MessageManagement*) the computation and 2) the display of the target view component (in this case, the *MessageList* component is computed with the selected *MailBox* as input parameter and displayed).

The model of Figure A.6 can be refined to show the parameter binding that binds the selection of a *MailBox* in the *MailBoxList* component and the display of the messages *of that MailBox* in the *MessageList* view component.

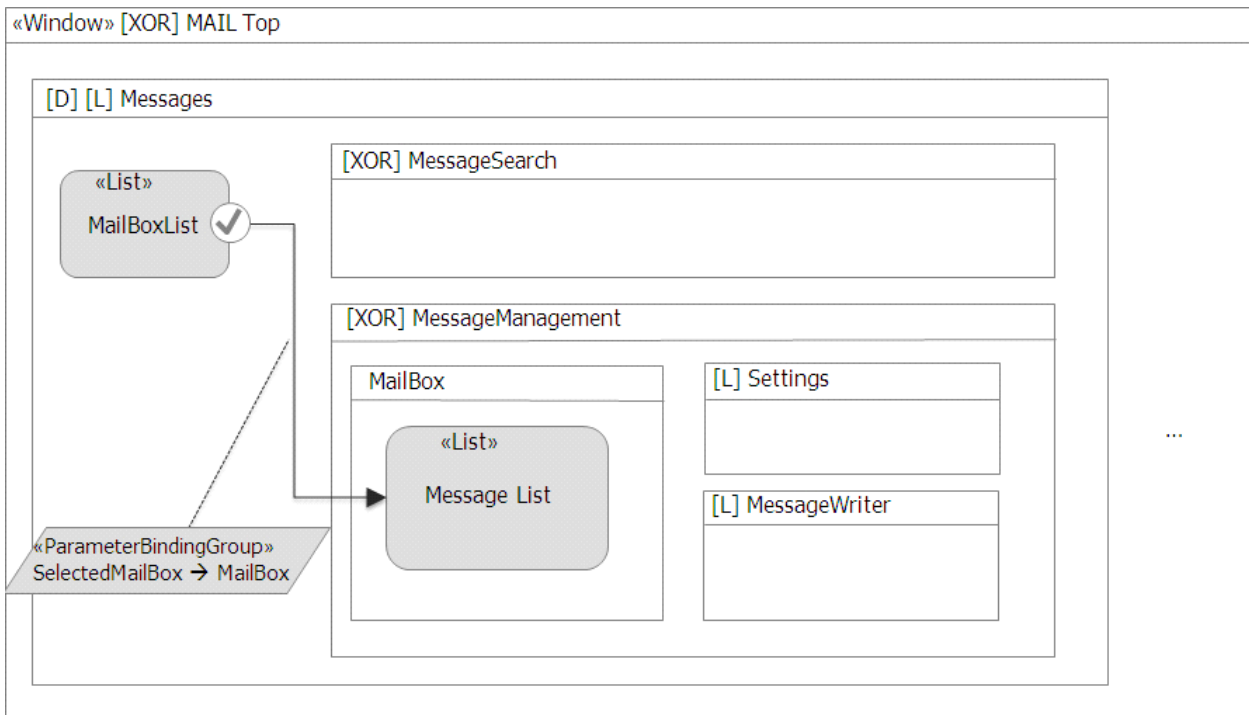

Figure A.7 - Notations to express (or infer) parameter dependencies between view components

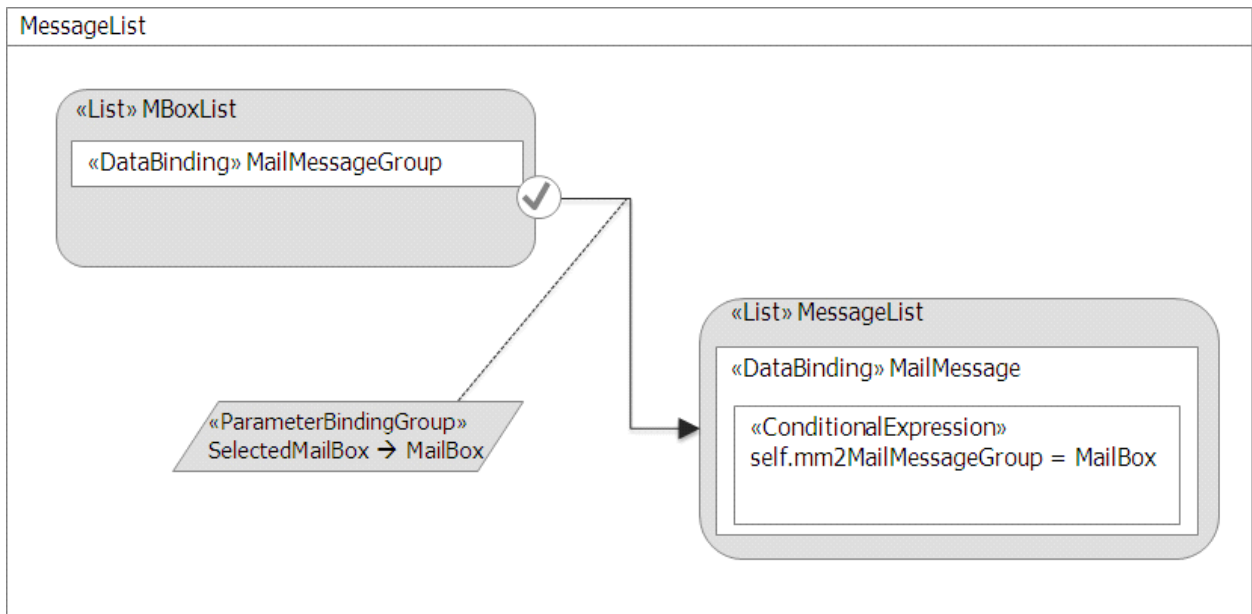

Figure A.8 - Notations to express (or infer) parameter dependencies between view components with extension mechanism

Language extension and notation

1. In the upper part of Figure A.8, a UML-style annotation explicitly expresses that an output parameter of the source component is associated with an input parameter of the target component.
2. In the lower part of Figure A.8, the model makes use of the IFML extension mechanism. A «List» component is introduced, which extends the basic view component to represent a list of dynamically extracted data objects⁵. The component refers to a content binding of the DomainModel where the objects of the list belong; it may also refer to an expression to denote a filter on the instances to display. In this case, the join expression on relationship *mm2MailMessageGroup* (see the example DomainModel) dictates that only the messages of the mail box received as an input parameter are displayed. The semantics of the component may specify default input and output parameters, so that the parameter binding can be inferred and need not be explicitly represented: the default output of the *MailboxList* list component is defined as the selected object of type *MailBox*; the default input of the *MessageList* list component is an object of type *MailMessageGroup*, as specified by the join expression on the relationship *mm2MailMessageGroup*. Since these two parameters match, there is no need of expressing the parameter binding explicitly.

The *MessageList* component supports the interaction with mail messages, individually or in sets. On the entire set of messages, the *MarkAllAsRead* event permits the user to update the message in the current *MailBox*, setting their status to “read” (see Figure A.9).



Figure A.9 - The MarkAllAsRead user-generated event marks all messages in the current mail box as “read”

As shown in Figure A.10, the *MessageList* supports a second kind of interaction: the selection of a subset of messages; when there is at least one selected message, a view container is displayed (*MessageToolbar*), which permits the user to perform several actions in the selected messages: archiving, deleting, moving to a *MailBox/Tag*, reporting as spam, etc.

In summary, the *MessageList* component supports three types of interactive events:

1. an event for selecting the entire set of messages and triggering an action upon them, marking all as read (Figure A.9);
2. an event for selecting/deselecting one or more messages (Figure A.10);
3. an event for selecting an individual message and opening it for reading.

5. IFML has an extension mechanism whereby generic view and business components can be extended to introduce domain-specific view and business logic. Object publishing and CRUD operations on objects are typical examples of extended components.

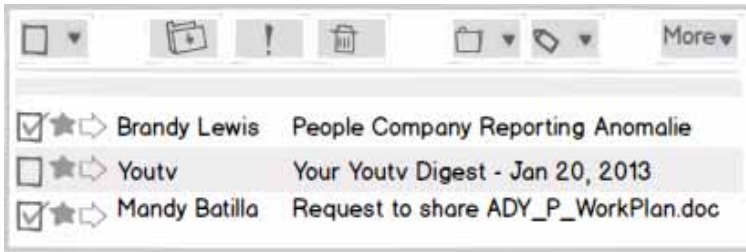

Figure A.10 - When one or more messages are selected in the *MessageList* component, the *MessageToolbar* view container is displayed, which allow the user to perform several actions of the selected set of messages. If all messages are deselected, such view container is no longer displayed.

Language extension and notation

1. For making the model more self-explaining and supporting code generation better, it is possible to further extend IFML with a specific view component: the *MultiChoiceList* (Figure A.11). The multi choice list would extend the behavior of the list view component with more event types: the default type (denoted by the default notation) expresses the selection of one element of the list; the selection/de-selection event type, denoted by a ticker icon, expresses the selection or de-selection of any number of elements; the set selection event type, denoted by an asterisk, denotes the triggering of an action on the entire set of element of the list.

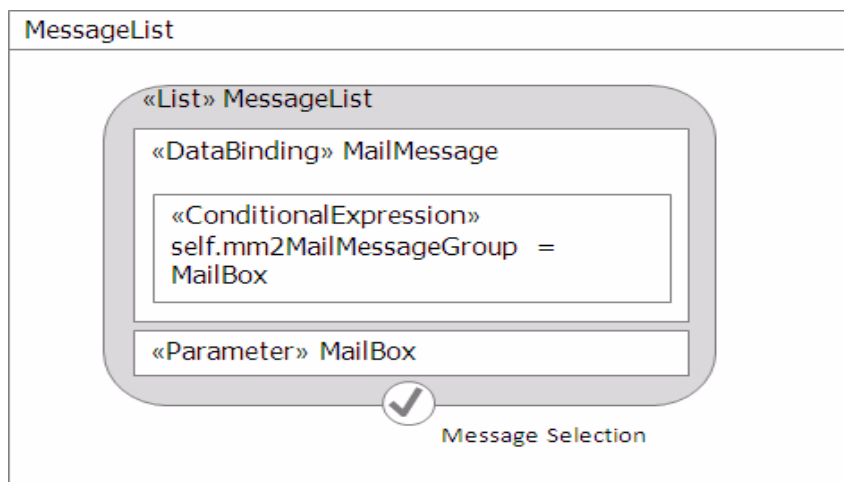

Figure A.11 - The «Multi-choice List» view component extends the «List» view component to enable more types of interaction events with the element of the list.

The behavior of the *MessageSelection* event of the *MessageList* view component that triggers the display of the *MessageToolbar* view container is modeled as shown in Figure A.12.

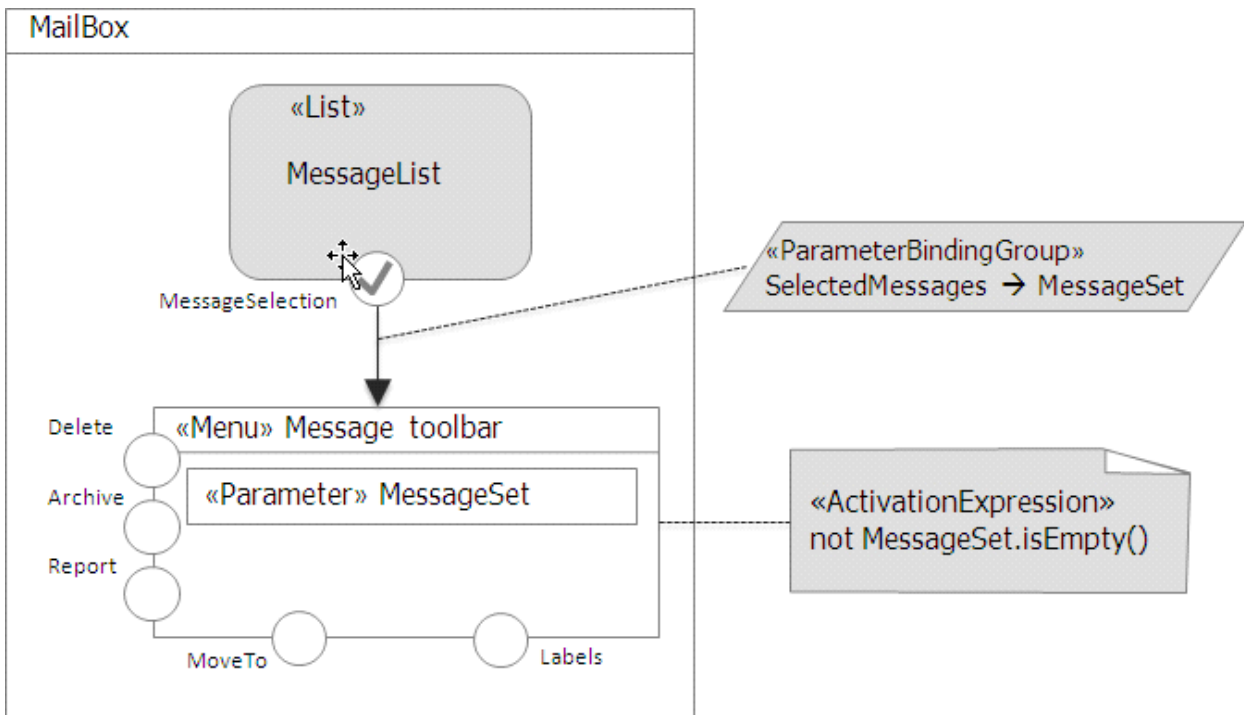

Figure A.12 - User events that mark one or more messages in the current mail box produce the display of the MessageToolbar view container, which remains visible/active if at least one message is selected.

The *MessageSelection* event has a parameter binding, which associates the (possibly empty) set of currently selected messages with an input parameter of the *MessageToolbar* view component. The *MessageToolbar* view component is associated with an (activation) expression, which tests that at least one message is selected.

Notation

1. For better readability of the model, it is possible to name the events, as shown in Figure A.11 and in Figure A.12. This annotation can be a guide for producing the implementation, for example it can be used to generate the labels of buttons and links, the tool tips of commands, and other similar usability aids.

Semantics

1. The association of a boolean expression to a view container means that the view container is active/visible if the expression evaluates to true.

The actions performed by the user on the messages (all, or a subset thereof) are represented as shown in Figure A.13. An interaction flow arrow connects the event responsible of triggering the action to the action itself, supporting the specification of parameter bindings.

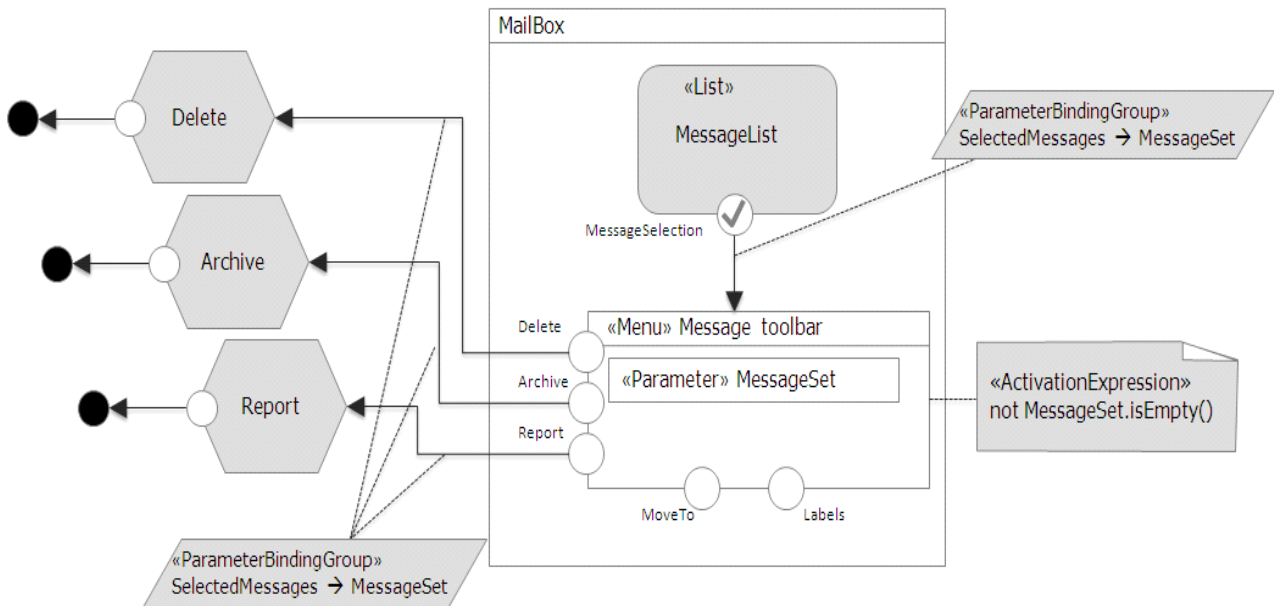

Figure A.13 - The *MessageList* view component and the *MessageToolbar* view container are associated with events that trigger actions on messages. Actions are represented as components placed outside the view containers, with input and output parameters.

For example, the output parameter (*MessageSet*) of the *MessageToolbar* view container is associated with an input parameter of the business actions *Delete*, *Archive*, and *Report*.

The execution of an action produces an action completion event and the sending of an asynchronous throwingEvent notification, denoted as a black circle reached by the outgoing InteractionFlow from the Action box. Such a notification throwing event is matched by a catching event, which triggers the display of a *MessageNotification* view component, shown in Figure A.14.

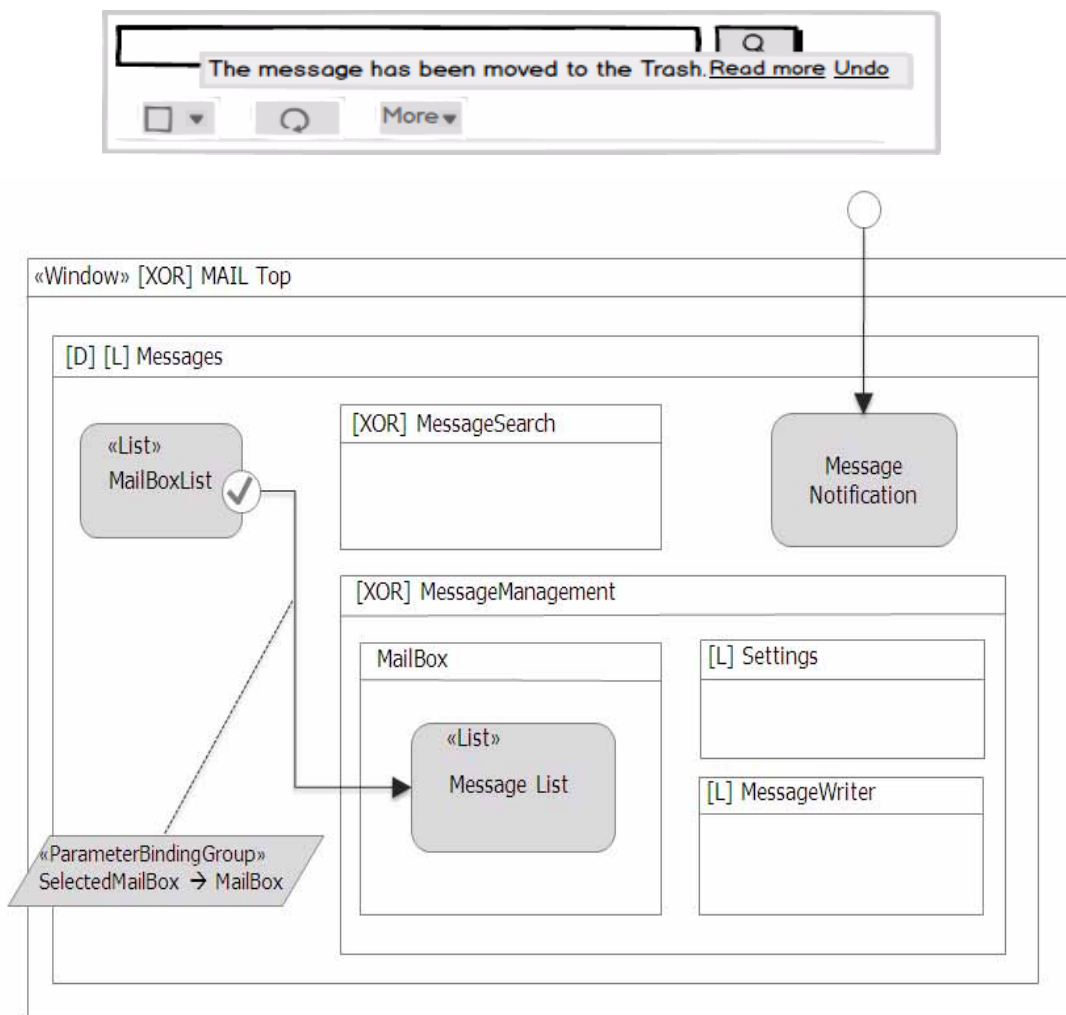

Figure A.14 - The *Messages* view container comprises a message notification component, which displays notifications of executed actions on *Messages* (illustrated above).

Note that the notification reception event is associated with the parameter *MessageSet*, which can be used in the *MessageNotification* component, e.g., to support the undo of the action⁶ (not modeled for brevity).

Some actions on mail messages require a more elaborate interaction flow: *Move to folder* and *Associate with tag* (see Figure A.18). For example, moving a set of selected messages to a folder is done by first accessing a view container in a new window with the list of available *MailBox* and *Tags* (shown in Figure A.15) and then selecting from such list the destination *MailBox* or *Tag*.

6. Modeling the undo also requires discriminating the action to undo, which can be simply modeled, e.g., with an additional parameter denoting the type of action (e.g., delete) set by each action when creating an instance of the notification sending event.

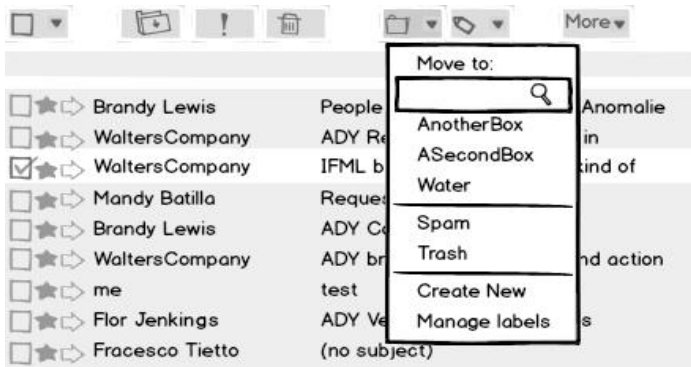

Figure A.15 - The *MoveTo* action is activated by first accessing a modal view container with the list of the available *MailBoxes* and *Tags* and then selecting the target one. The view container comprising the list of *MailBoxes* and *Tags* is also associated with navigation events for creating new tags and managing existing tags.

The view container comprising the list of *MailBoxes* and *Tags* is also associated with navigation events for creating new tags and managing existing tags. For example, the *Create New* event causes a modal view container to be displayed, whereby the user can create a new tag and associate the selected messages with it (see Figure A.16).



Figure A.16 - The *Create New* event causes a modal view container to be displayed, whereby the user can create a new tag and associate the selected messages with it.

The interaction flow for moving a message to an existing or newly created tag is represented in Figure A.17. The view container stereotypes «Modal» and «Modeless» annotate the view containers to specify that they open in a new window and are modal or modeless.

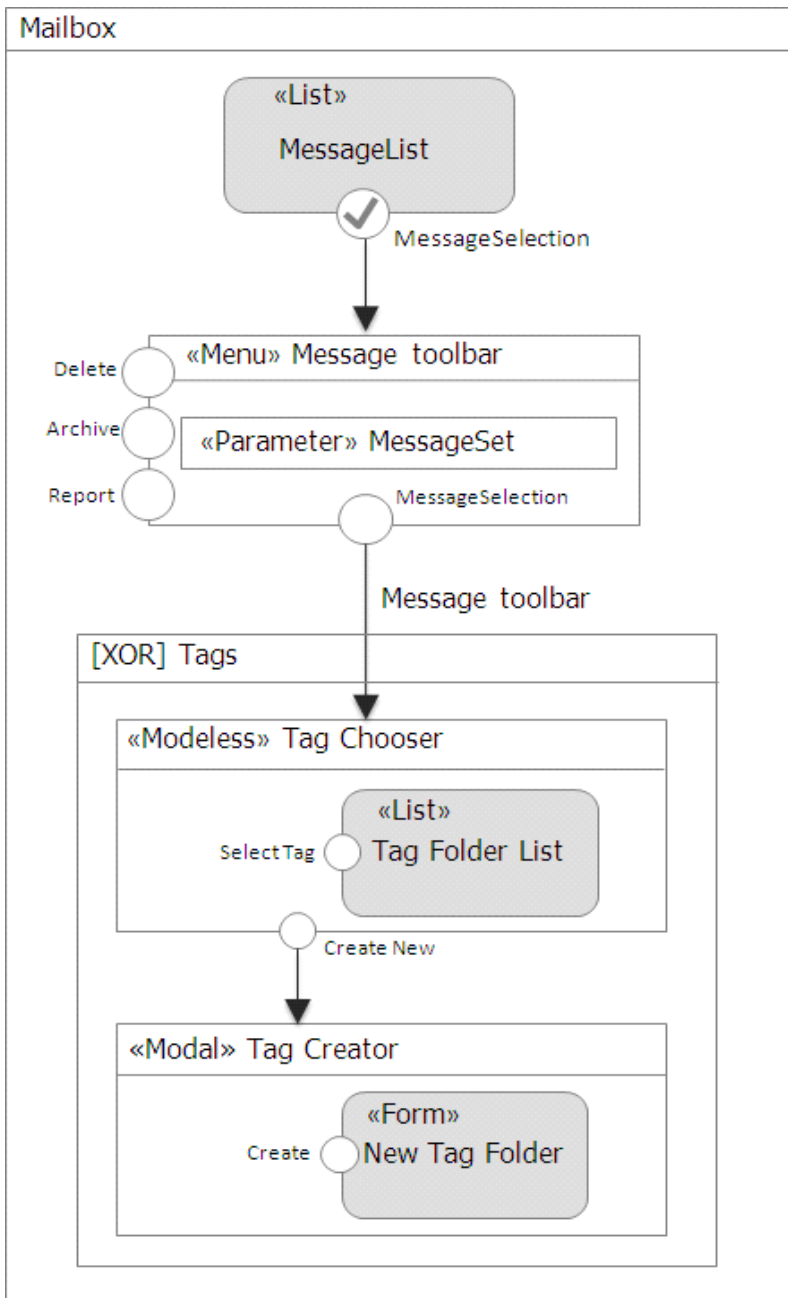

Figure A.17 - The model of the interaction flow for moving a message to an existing or newly created tag. The view container *TagChooser* is a modeless view container (which hides when clicking outside of it) and the *TagCreator* is a modal view container.

Archiving, reporting, and associating messages to existing/new tags imply the invocation of business logic components, as shown in Figure A.18.

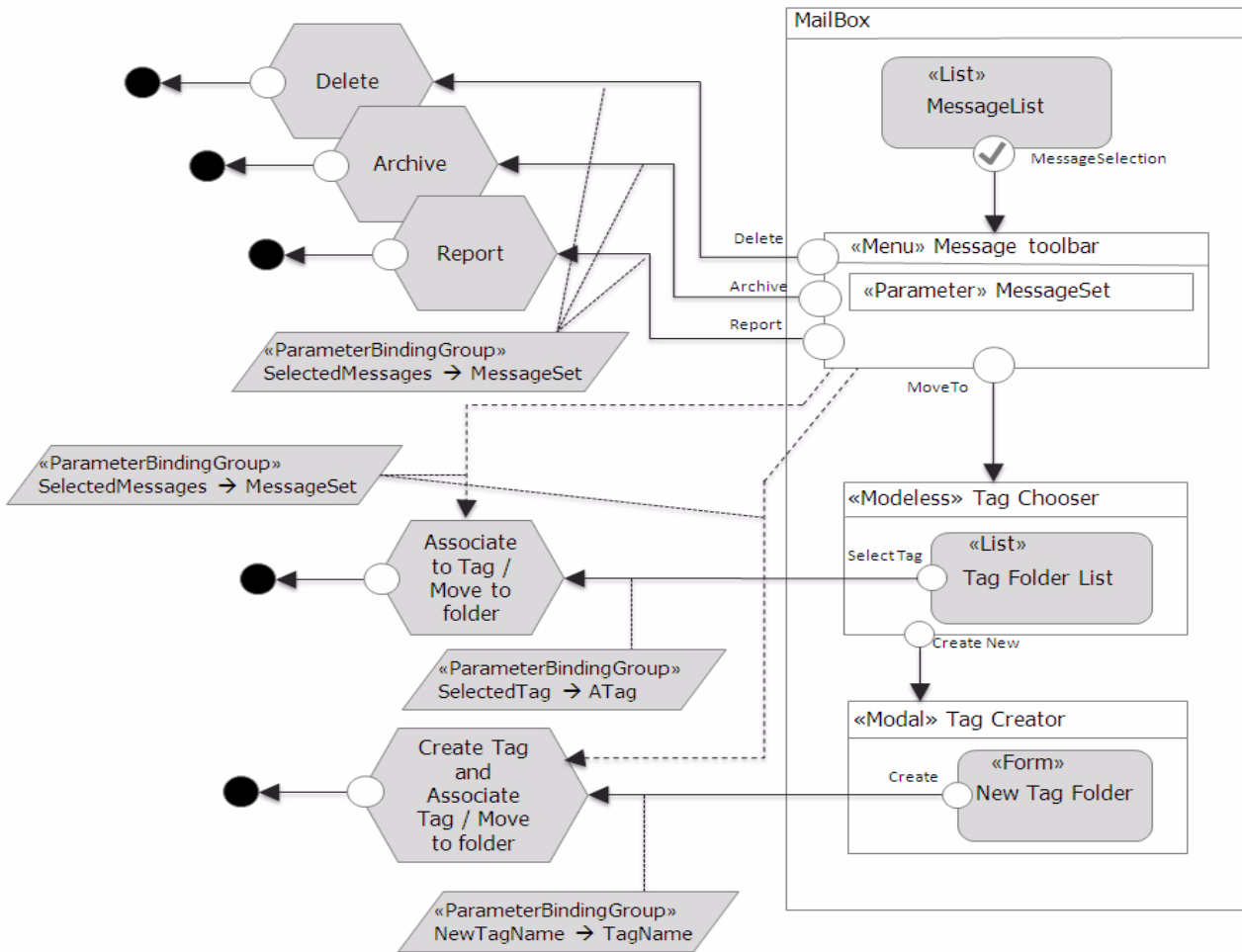

Figure A.18 - The model of the interaction flow for moving a message to an existing or newly created tag

In Figure A.18 the parameter bindings are modeled explicitly: 1) the selected mail messages are associated with the input of the *Delete*, *Archive*, and *Report* actions; 2) the *SelectedTag* parameter, which corresponds to the user's choice of a tag to associate with a set of messages, is the input of the *AssociateToTag* action⁷. Note that the *AssociateToTag* action receives the selected message set through a DataFlow (dashed arrow) coming from the MessageToolbar ViewContainer; 3) the *NewTagName* parameter, which corresponds to the new label entered by the user, is the input of the *CreateTag* action.

The specification of composite action flows is not allowed but the internal functioning of an action could be specified with an orchestration model (e.g., a UML activity diagram, a SOAML specification, etc.).

The access to the messages can also occur through a search functionality. An input field supports simple keyword based search; with a click, the user can also access a more powerful search input form, where he can specify several criteria to be matched, as shown in Figure A.19.

7. For simplicity, which only model the AddToTag functionality; the MoveToFolder command is similar.

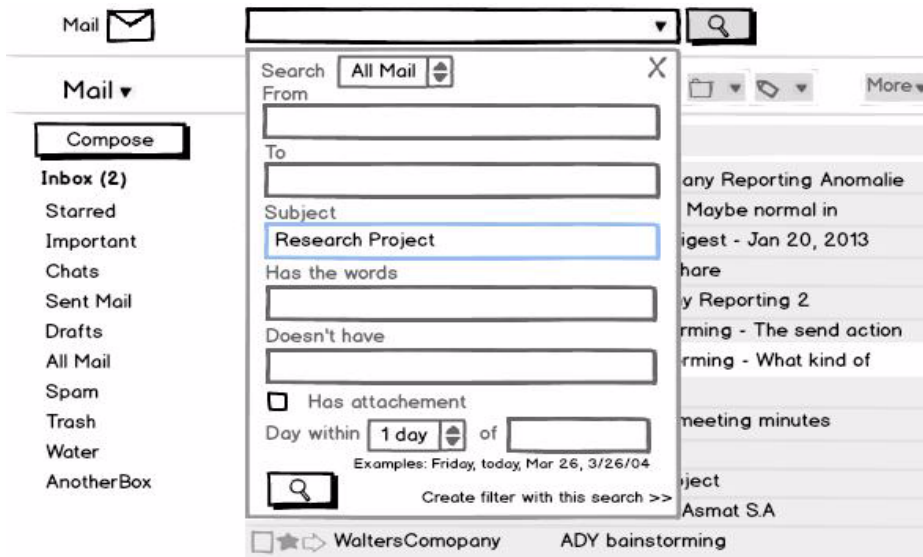

Figure A.19 - The message search functionality (full search modal view container)

The IFML model of the search functionality (shown in Figure A.20) comprises a view component (*MessageKeywordSearch*) for entering a string to be matched to the mail messages and filter those to be displayed in the *MessageList* view component. Such an interaction flow can be represented with an event associated to the *MessageKeywordSearch* and an interaction flow to the *MessageList* view component; a parameter bindings specifies that the output parameter of the *MessageKeywordSearch* view component is associated with the input parameter of the *MessageList* view component. From the *MessageKeywordSearch* another event (*Show search options*) opens a modal view container (*FullSearch*), where the user can input more information to drive the search. In this latter case, the parameter binding associates each field value of the Form view component to a respective input parameter of the *MessageList* component. Note that after giving the input of the *FullSearch* two navigations occur. One for the *MessageList* for showing the search result and another to the Search container for passing and displaying the keyword search.

The example shown in the right part of Figure A.20 illustrates how extending the basic IFML view components with domain specific view and business logic can make the model more self-descriptive. For instance, one could define a view component abstracting the notion of input forms for data entry (denoted by the stereotype «Form»), composed of a set of typed fields (e.g., denoted as nested view components of type «SimpleField»); a «Form» component could expose as default parameters, the values of the contained fields. The parameter binding would then couple each input field with the respective parameters of the ConditionalExpression expression of the dynamic list component (as shown in the right part of Figure A.20). Note that the «List» view component is associated with multiple ConditionalExpression expressions, which are used to compute the component when different navigation events occur. Which expression has to be evaluated is dictated by the parameter binding associated with the interaction flows of the event triggering the computation.

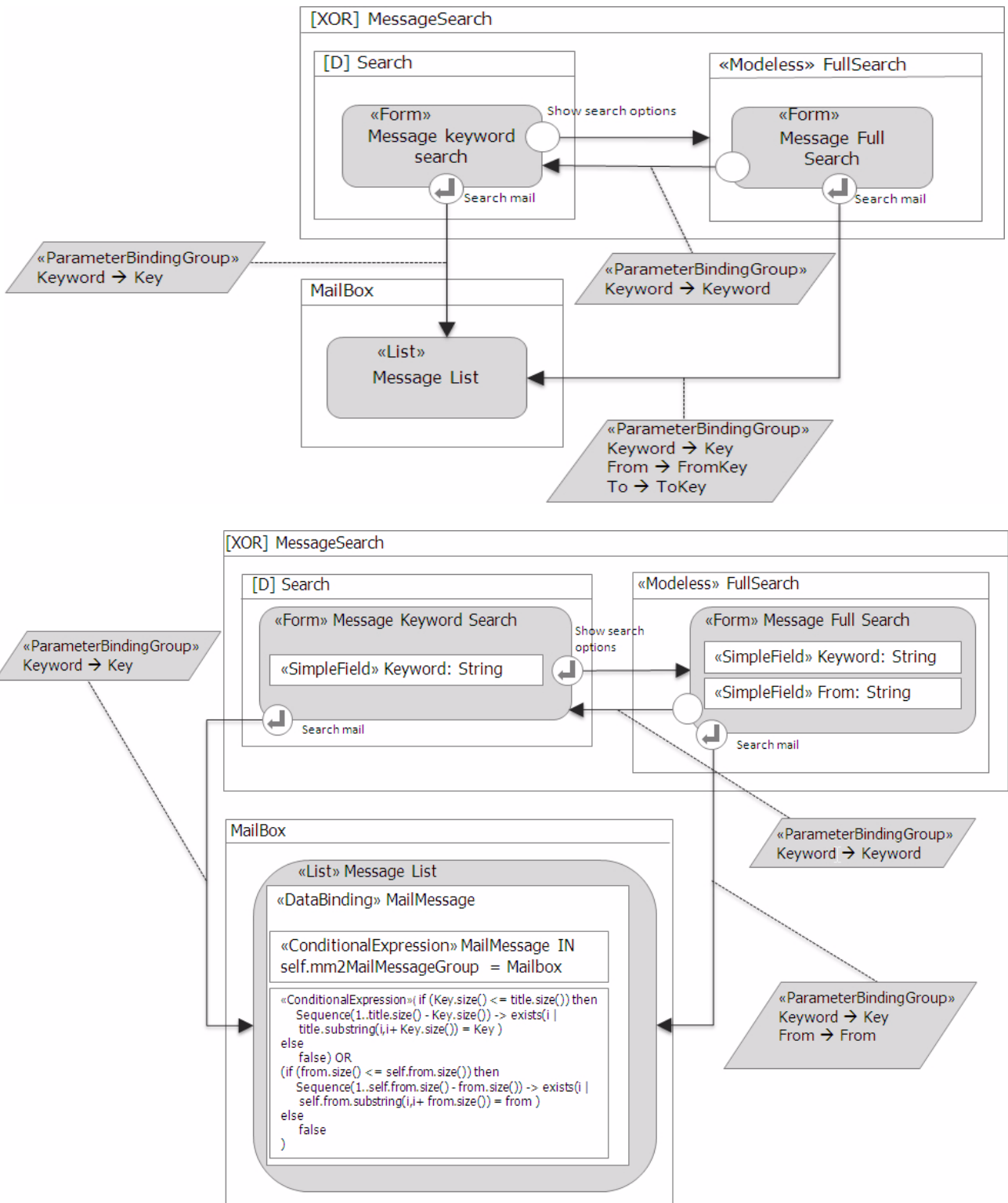

Figure A.20 - The model of the message search functionality (top). The same model refined with the use of the extended view components «Form» and «List» (bottom).

As shown in Figure A.21, the selection of a message from the *MessageList* view component causes the *MessageDetails* view component to be displayed. Such a component permits the user to access one specific message at a time. The XOR *MessageReader* ViewContainer enables alternative visualization of the *MessageDetails* and *MessageList* ViewComponents.

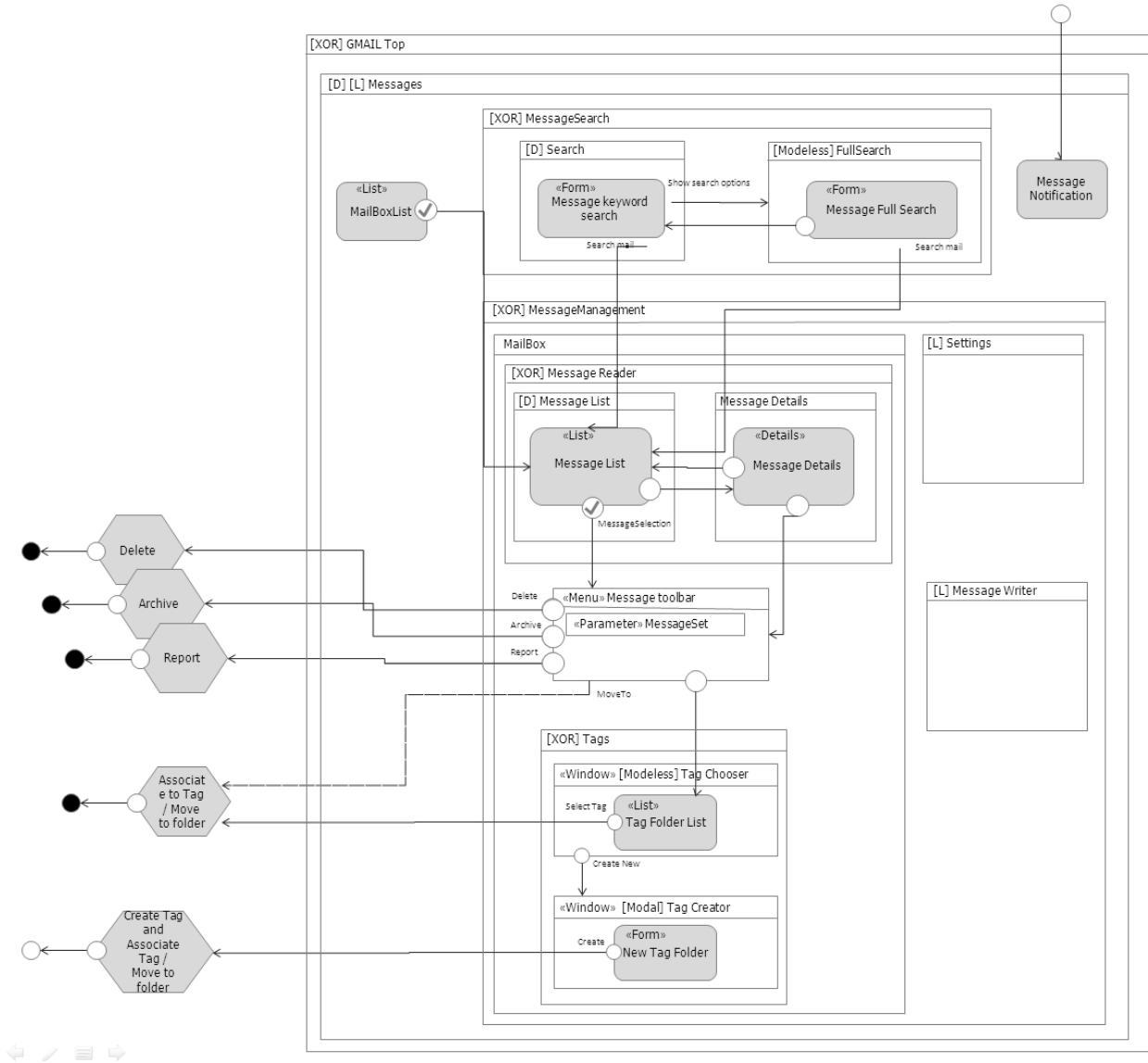

Figure A.21 - The *MessageList* and the *MessageDetails* view components are shown in alternative

The example continues with the model of the message composer functionality. This can be activated in two ways: 1) from any view containers inside the *Messages* top view container as denoted by the landmark icon of the *MessageWriter* view component; 2) from the *MessageDetails* view component, by activating the *Reply*, *ReplyToAll*, or *Forward* command, as denoted by the three event and interaction flows from the *MessageDetails* view component (shown in Figure A.22).

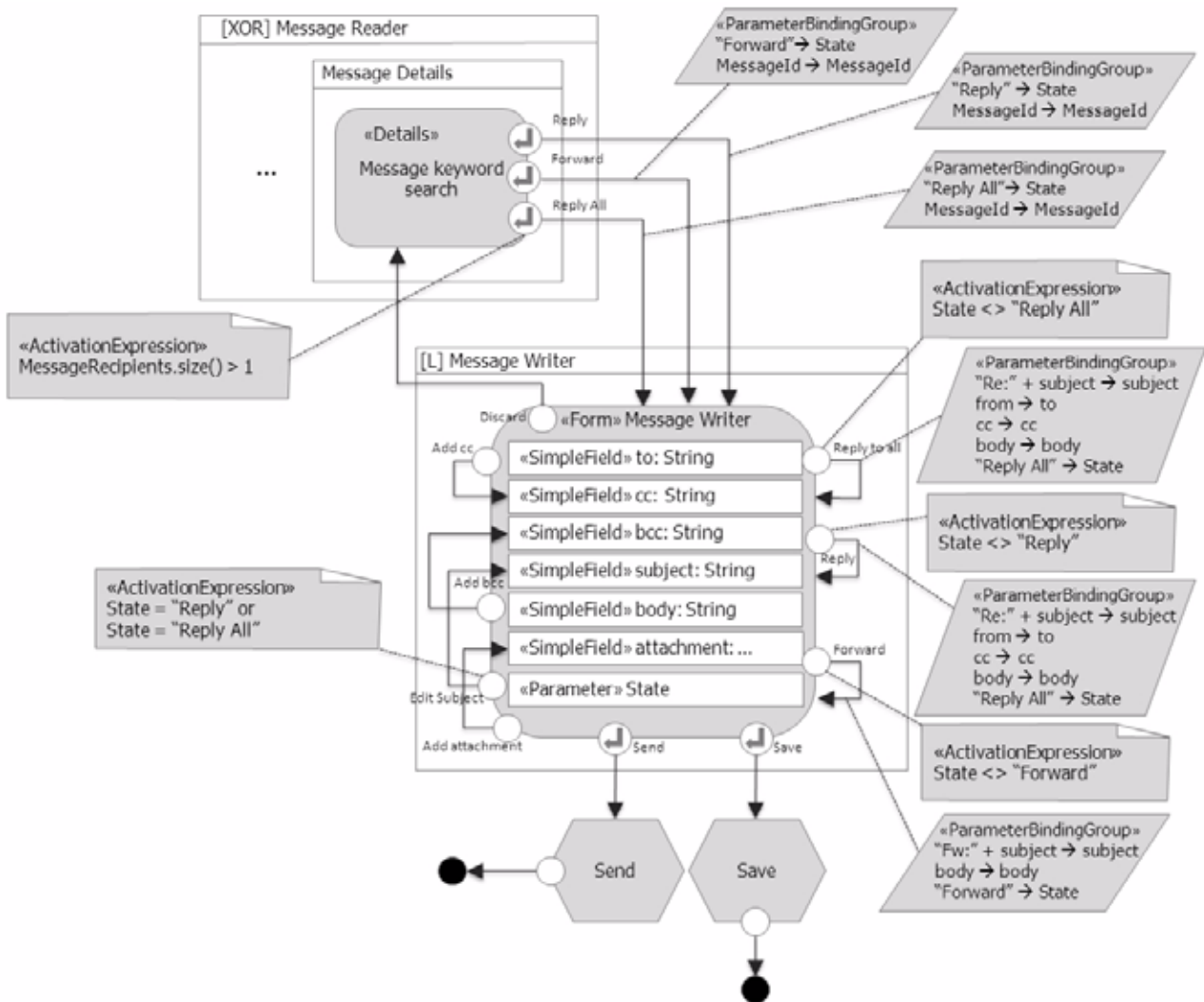

Figure A.22 - The different ways to access the *MessageWriter* view component

The link *ReplyToAll* is active only when the message displayed in the *MessageDetails* view component is associated with more than one recipient. This can be expressed as a activation expression associated with the *ReplyToAll* event (see Figure A.22). The *MessageWriter* view component has an internal structure, shown in Figure A.23.

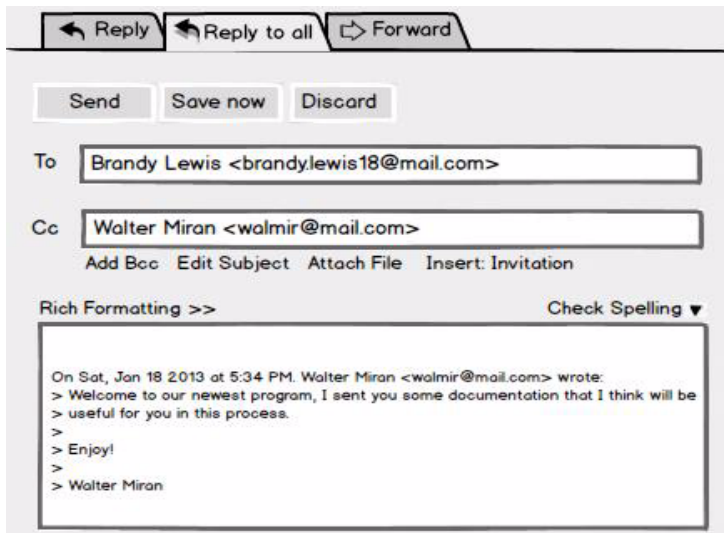

Figure A.23 - The internal structure of the MessageWriter view component

The view component permits the user to edit a new message, reply to an existing message (to the sender only or to all) and to forward an existing message. The view component can be represented as a form composed of different fields: *To*, *Cc*, *Bcc*, *Subject*, *Body*, and *Attachment*.

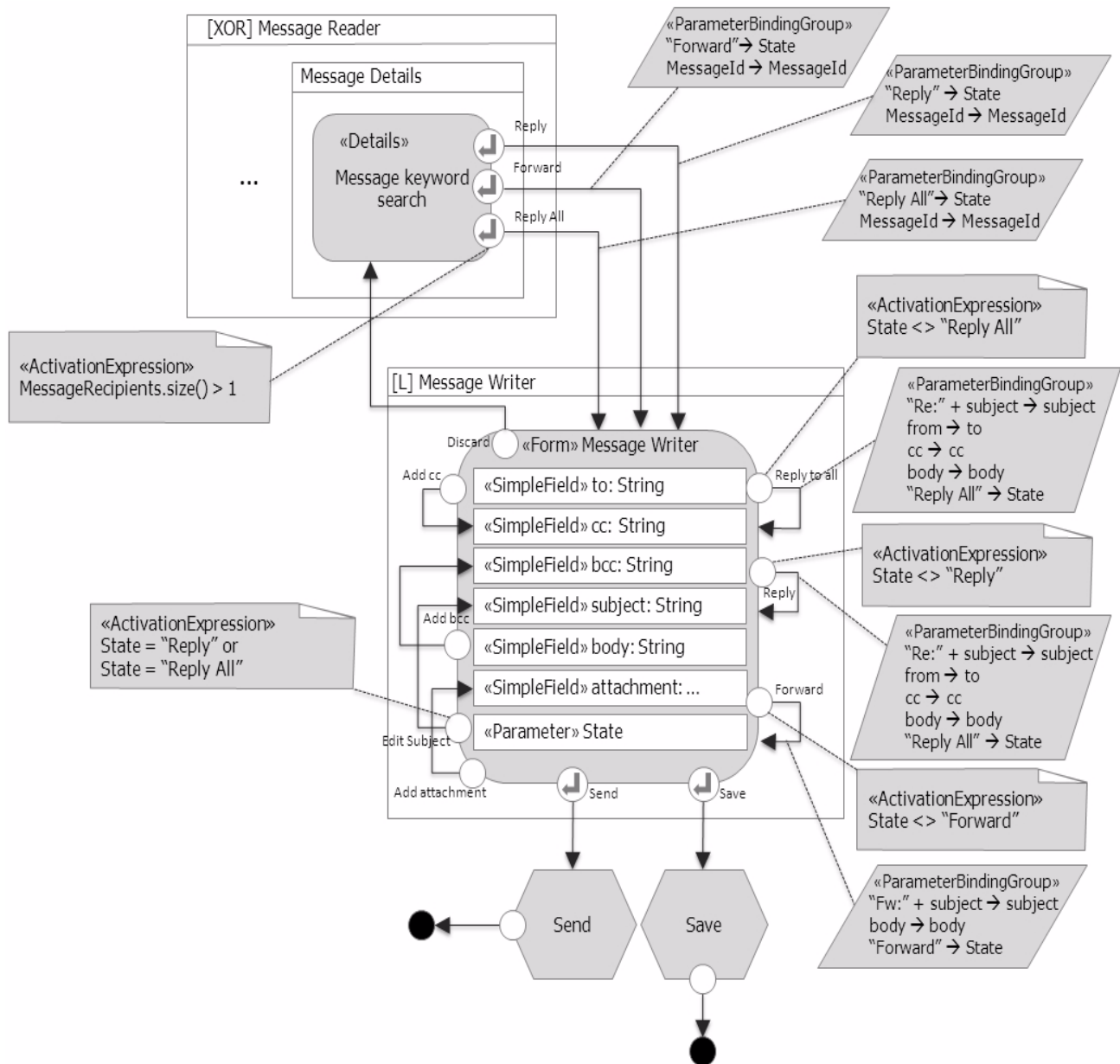

Figure A.24 - The IFML model of the internal structure of the *MessageWriter* view component, with the names of the event displayed for clarity.

Note that some form fields can be automatically filled with content (e.g., the *To* field is automatically set to the mail address of the sender when the *ReplyTo* event is raised). This is modeled by considering that each «SimpleField» component of a «Form» component is associated to an implicit input parameter that denotes the value of the field.

In addition to the form fields view component parts, the *MessageWriter* view component has an explicit parameter (*State*), which denotes four different edit configurations: 1) when the user is editing a new message, 2) replying to the sender of an existing message, 3) replying to the sender of an existing message and to all recipients in copy, or 4) forwarding an existing message. These edit configuration differ in the subset of fields that are automatically filled-in and in the commands that are enabled: for example Figure A.23 shows the edit configuration when the user is replying to the sender of an existing message and to all recipients in copy.

The *MessageWriter* view component is associated with three events (*Reply*, *ReplyToAll*, *Forward*) for switching from one of the *ReplyTo*, *ReplyToAll*, and *Forward* editing configurations to the other two. For example, Figure A.24 shows that the event *ReplyToAll* is active only when the *State* parameter has the value *Reply* or *Forward* and that its effect is to assign a value to the *Subject*, *To*, *Cc* and *Body* field, and set the *State* parameter to the value *ReplyToAll*.

Another example of conditional event is the *EditSubject* one: the event for editing the subject field is available only when the *State* parameter is *ReplyToAll* or *Reply*.

The model refinement of the *MessageWriter* view component can go on, by zooming-in inside the *Body* field. The *Body* field can be refined by a nested component, which supports client-side business logic like the rich formatting and the spell checking of the text.

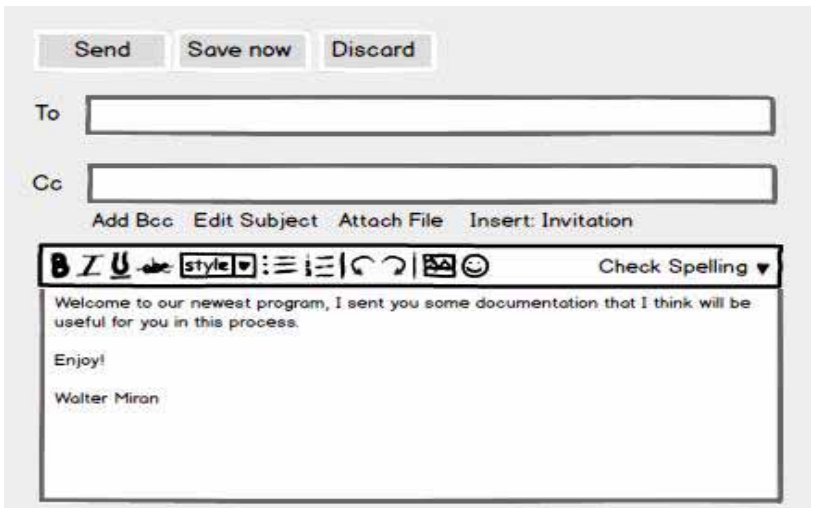

Figure A.25 - The rich text editing toolbar in the *Body* input field of the *MessageWriter* view component

Figure A.25 shows the rich text editing toolbar in the *Body* input field of the *MessageWriter* view component, which appears when the user clicks on the *RichFormatting* link shown in Figure A.23.

A number of editing commands apply to the text, which rewrite the content of the view component at the client side. Similarly, the *CheckSpelling* command triggers a client-side action that highlights in red the misspelled words.

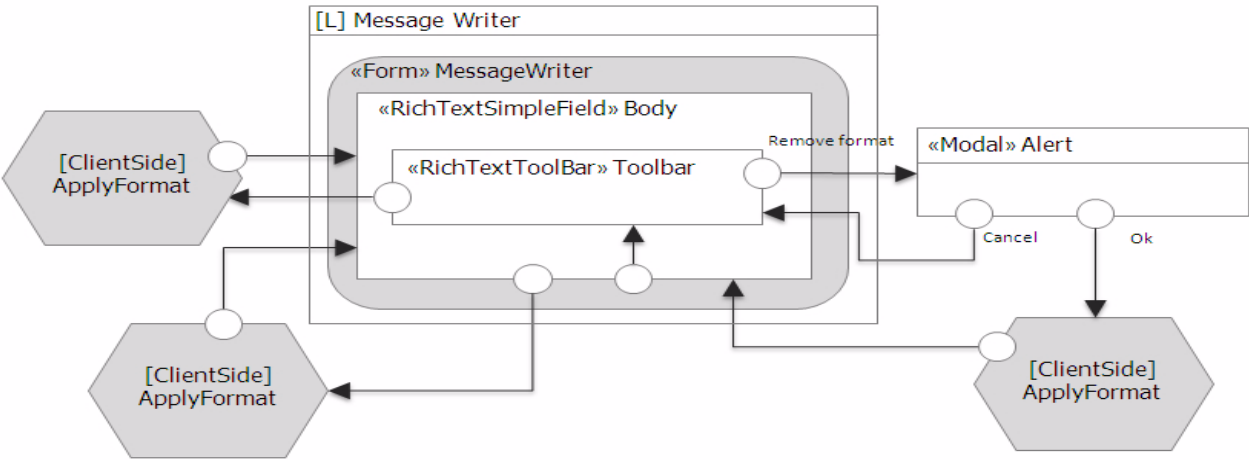

Figure A.26 - The rich text editing toolbar in the *Body* input field of the *MessageWriter* view component

Figure A.26 shows the IFML model of the rich text editor field. An event corresponding to the *RichFormatting* interaction flow permits the user to access the *Rich Text Toolbar* view container, which comprises a number of commands for applying formatting to the text; for brevity, we summarize these commands as the invocation of the *ApplyFormat Action*, which is shown with the [ClientSide] icon to denote that it actuates at the client side. Similarly, an event permits the user to trigger the *SpellCheck Action*, which is also client-side. Finally, from the *RichText Toolbar* view container an event (the *PlainText* link visible in Figure A.25) permits one to remove the formatting and go back to the plain text mode; before firing the action, though, an alert modal view container is presented where the user can confirm or discard the format removal action. Discarding the action leads one back to the *Body* component and to the *Rich Text Toolbar*.

Annex B

IFML by Example: Modeling an Online Bookstore

(informative)

B.1 Introduction

This annex exemplifies the the versatility and adaptability of IFML by modeling the most common features available in a simple UI for a point of sale (POS) management, specifically targeted to a bookstore environment.

B.2 Domain Model

During the session, a User is assigned a Shopping cart that at the beginning is empty. As the user browses through the page and gets information about the products available, adds products to the shopping cart. The list of products selected at the moment by the user, can be consulted at any time, offering the option of pay the current order, empty the cart, or continue browsing in order to add more products.

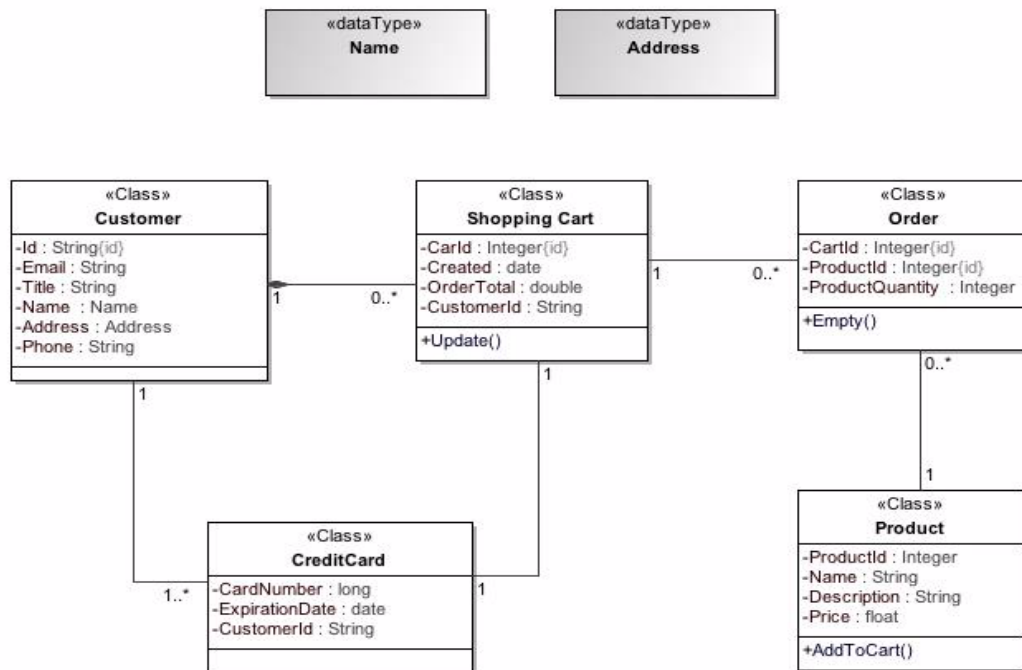

Figure B.1 - Domain Model of the Online Bookstore

B.3 Process Model

When the user enters into the website, starts exploring the products available. Once he finds a product of interest, selects it, and the item goes to the shopping cart. The user can either keep exploring products in order to add more items to his order, or continue to manage the shopping cart by deleting all the products, or updating quantities of the selected ones. Once the user is ready to proceed with the payment, performs the checkout.

In order to authorize the payment, it's necessary to send the customer information to the bank entity, and wait for the confirmation. This procedure is illustrated in Figure B.2.

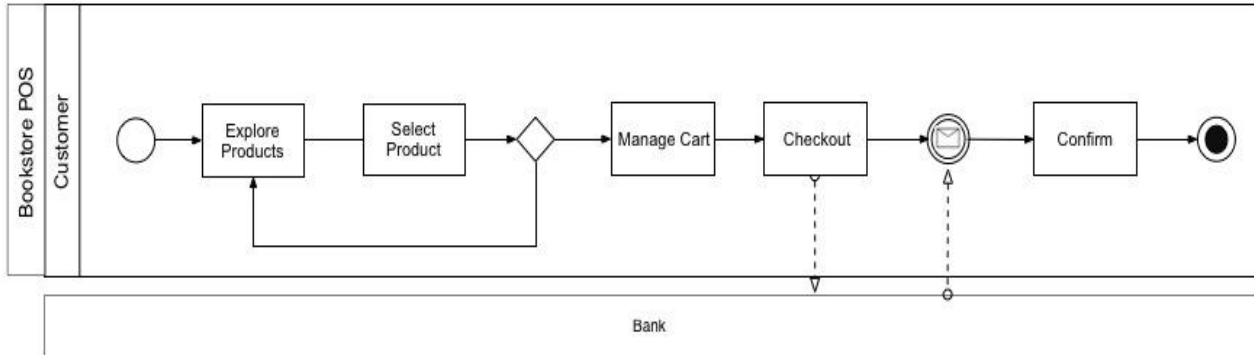

Figure B.2 - Process Model of the Online Bookstore

B.4 Model of the User Interaction Flow

Figure B.3 shows the home page of the online Bookstore. In this sub clause, the user can select one of the product categories, or go directly to the shopping cart.

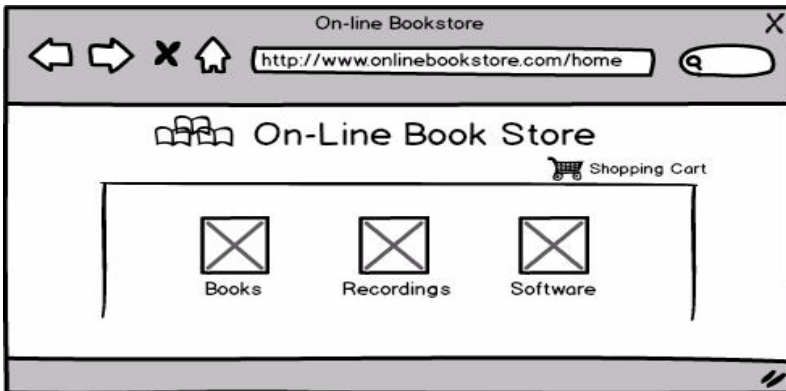

Figure B.3 - Online Bookstore Home Page

After selecting a category, a list of products is displayed. For instance, Figure B.4 shows all the products belonging to the books category.

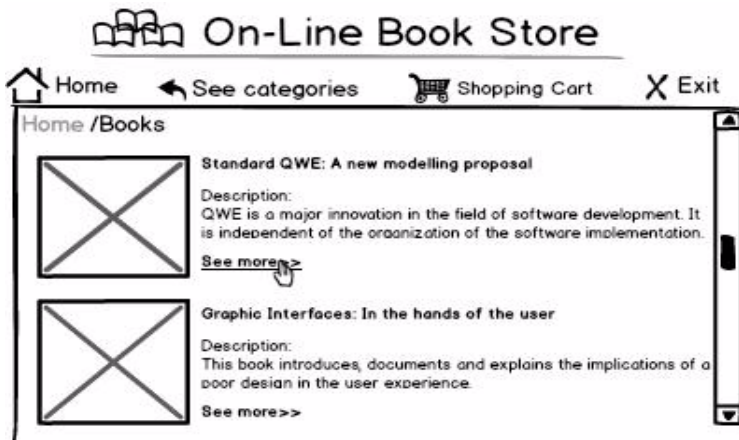

Figure B.4 - List of products belonging to the books category

When the user selects a product obtains the details of the selected item (such as full description and price) along with the option to add the product to the cart, as shown in Figure B.5.

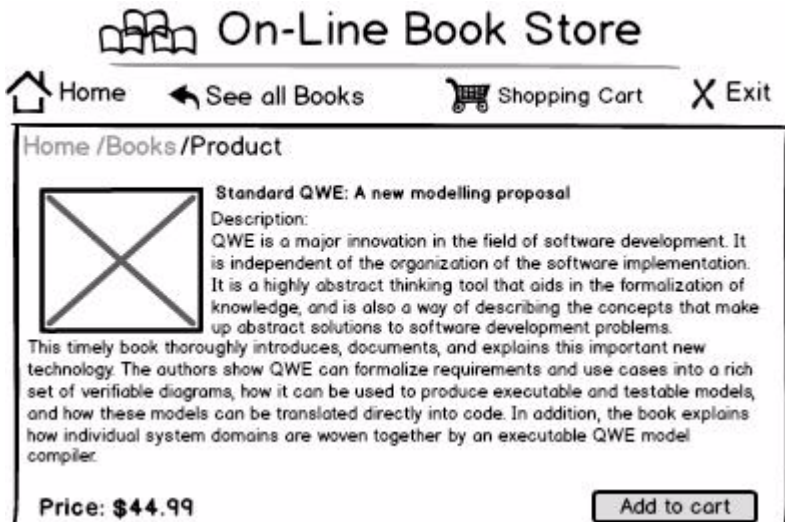

Figure B.5 - Details of the Selected Product

The procedure described in Figure B.3, Figure B.4, and Figure B.5 is represented in IFML as shown in Figure B.6. Once the user selects a category from *CategoryList* a navigation event is produced, and as a result, the products corresponding to the *SelectedCategory* are displayed. Similarly, when the user selects a product from *ProductList*, the details of the *SelectedProduct* are displayed.

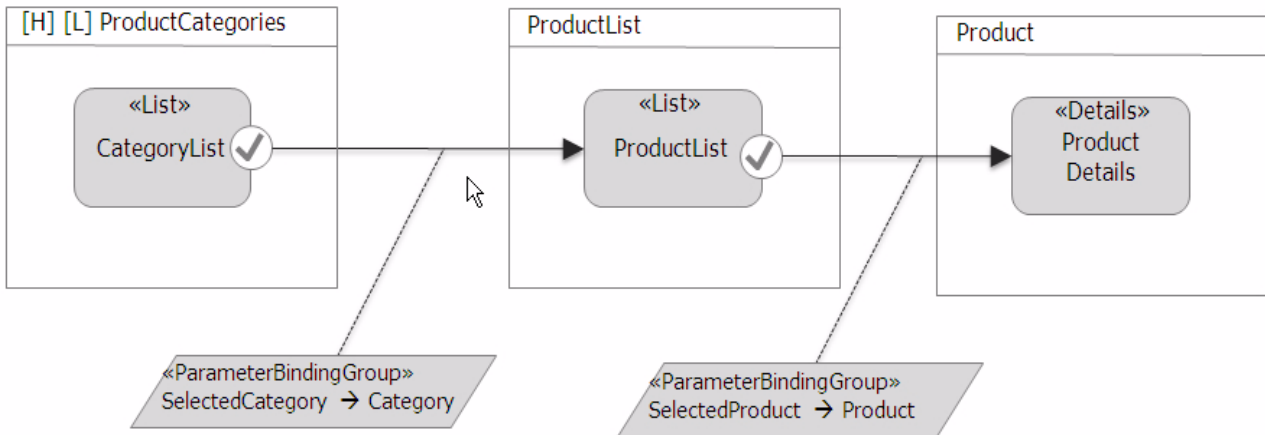

Figure B.6 - IFML model corresponding to the exploration of products

When the user decides to buy the product and add it to the cart, causes a modal view container to be displayed, where the user must provide the quantity of items of the desired product (see Figure B.7). After accepting the quantity, the article is added to the cart, and a confirmation window is displayed as shown in Figure B.8.

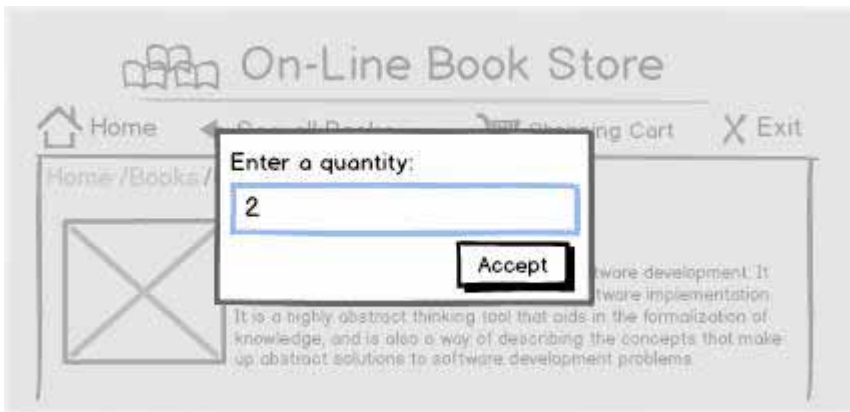

Figure B.7 - Window displayed in order to catch the number of items desired by the user

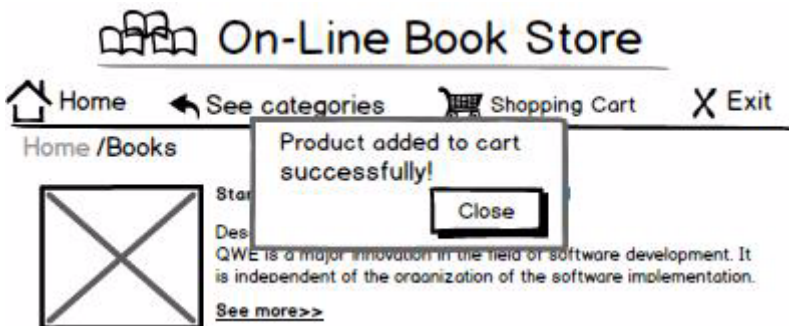

Figure B.8 - Confirmations window for the action add to cart

Figure B.9 shows the model fragment that adds a product to the cart: once the user press the add to cart button, a modal window appears asking for the quantity of items desired. This value, along with the *SelectedProduct* are submitted as parameters and represent the input of the add to cart action triggered. Once the action is performed, a confirmation window is displayed.

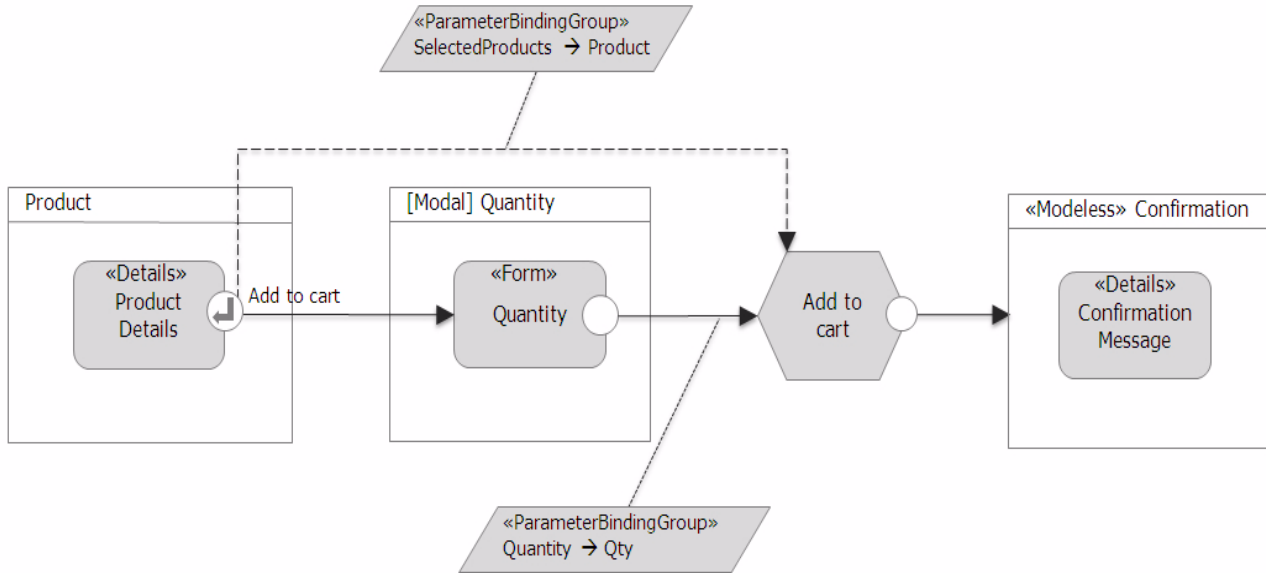

Figure B.9 - IFML model corresponding to the add to cart event

The shopping cart is the list of products previously selected by the user. In this sub clause are shown the quantities and the order details. The user is able to *update the cart* by changing the quantities, *empty the cart* by deleting all the products of the current order, and start the payment process by clicking in the *checkout* button (see Figure B.10).

When the user chooses to update the cart, the total amount is recalculated.

When the user empties the cart is redirected to a confirmation page as shown in Figure B.11.

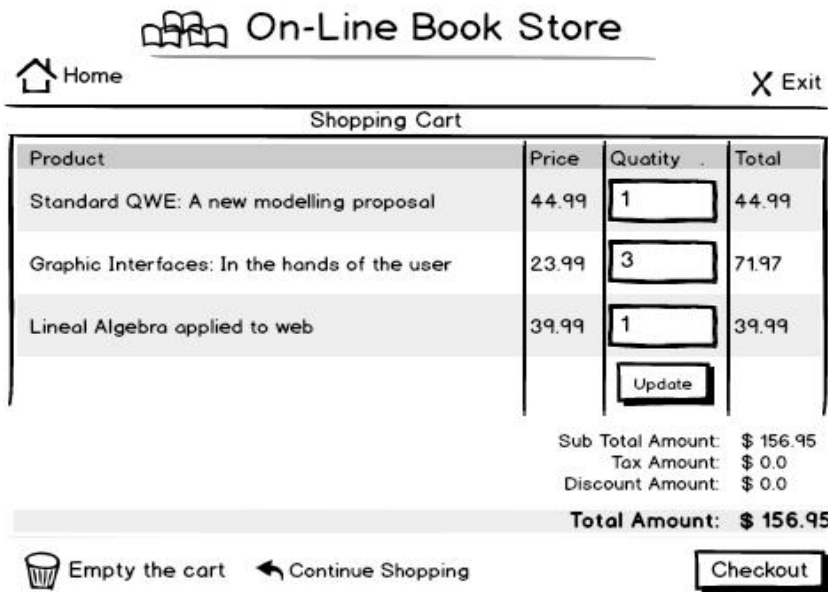

Figure B.10 - Interface of the Shopping Cart



Figure B.11 - Confirmation page for the Empty Shopping Cart Event

As illustrated in the IFML model of Figure B.12, when the user decides to delete all the items from the current order, the action *Empty the cart* is triggered, and after its execution, a confirmation message is displayed.

In the *Update* event, the user modifies the values of the quantities and submits them by clicking in the button *Update*; this event causes an *Update* action to be triggered after which the shopping cart is redisplayed (see Figure B.12).

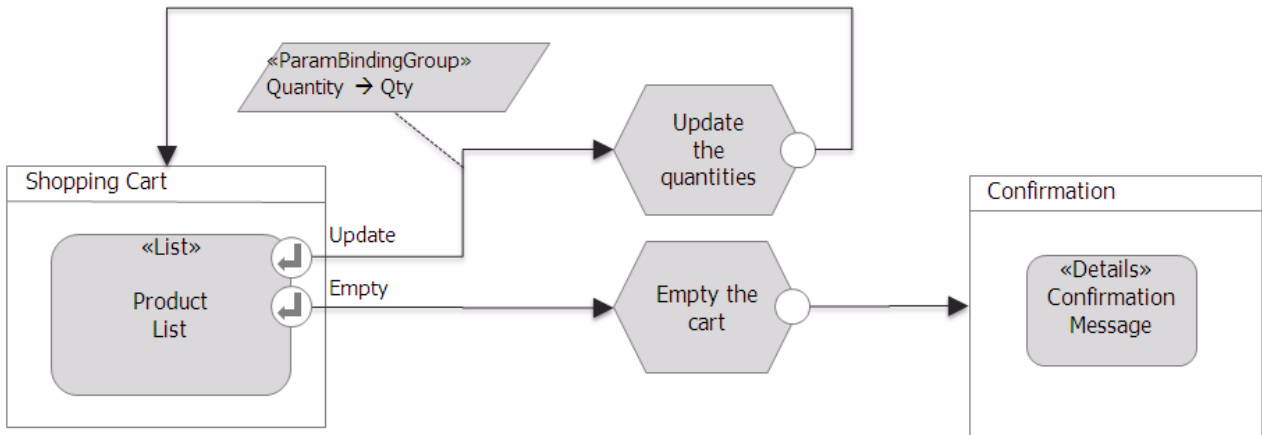

Figure B.12 - IFML model corresponding to the events Update and Empty of the Shopping cart

Once the user has decided to perform the payment, he must provide his personal information and press “Next” (see Figure B.13).

Home
 Shopping Cart
 Exit

Customer Information

E-Mail:	<input type="text" value="billy@mail.com"/>	Address Line 1:	<input type="text" value="Street Hamiton"/>
Title:	<input type="text" value="Mr."/>	Address Line 2:	<input type="text" value="45"/>
First Name:	<input type="text" value="Bill"/>	City:	<input type="text" value="New York"/>
Middle Name:	<input type="text"/>	State or Province:	<input type="text"/>
Last Name:	<input type="text" value="Feather"/>	Postal Code:	<input type="text"/>
Phone:	<input type="text" value="+51348576444"/>	Country:	<input type="text"/>

Figure B.13 - The user must provide its personal information and continue

After providing his personal information, the user must provide his bank account information and confirm the payment in order to proceed with the transaction (see Figure B.14). After performing the transaction, a confirmation page appears showing the details of the payment as shown in Figure B.15.

[Home](#) [Back](#) [Shopping Cart](#) [X Exit](#)

Payment Information

Cardholder Name: Mr. Bill Feathers

Address Line 1: Postal Code:

Address Line 2: Country:

City: Bank Card Account:

State or Province: Bank Card Expiration:

Total Amount: \$ 156.95

Figure B.14 - The user must enter the bank account information and confirm the payment

[Home](#) [See categories](#) [Shopping Cart](#) [X Exit](#)

Payment Performed Successfully!

Payment Details

CREDIT CARD COMPANY
 Charge to: 8765432567876 for: \$156.95
 Charge APPROVED

CUSTOMER: john.feathers@mail.com
 CHARGE APPROVED

Figure B.15 - Payment confirmation

When the user chooses the Checkout option, the container *Customer Information* is displayed. The user must provide his personal information by filling out the form within this container.

After the user submits his personal information, the container *Payment Information* is displayed. In this container the user must provide his bank account details. The name of the user (sent previously as the parameter: Name), is forwarded along with the credit card number (CC) and the total amount of the offer (previously sent by the shopping cart container) to the payment action (Execute the payment).

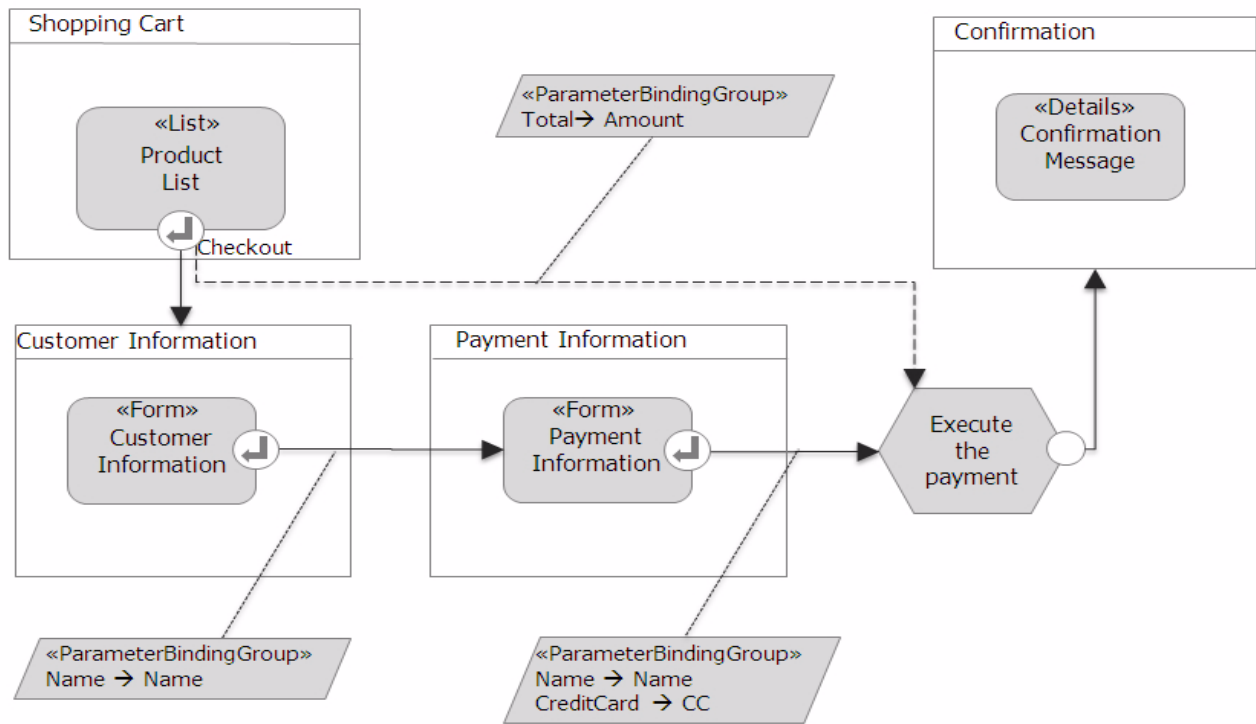

Figure B.16 - IMFL model corresponding to the event Checkout

After the payment execution, a confirmation message is displayed with the transaction details. The IFML representation of this procedure is shown in Figure B.16.

To increase reusability and modularization in the models, designers may decide to cluster homogeneous parts of the model into Modules. For instance, the part of the model that deals with the payment management can be packaged into a specific module. This would simplify the model of the application, which would appear as in Figure B.17.

The definition of the corresponding module is shown in Figure B.18.

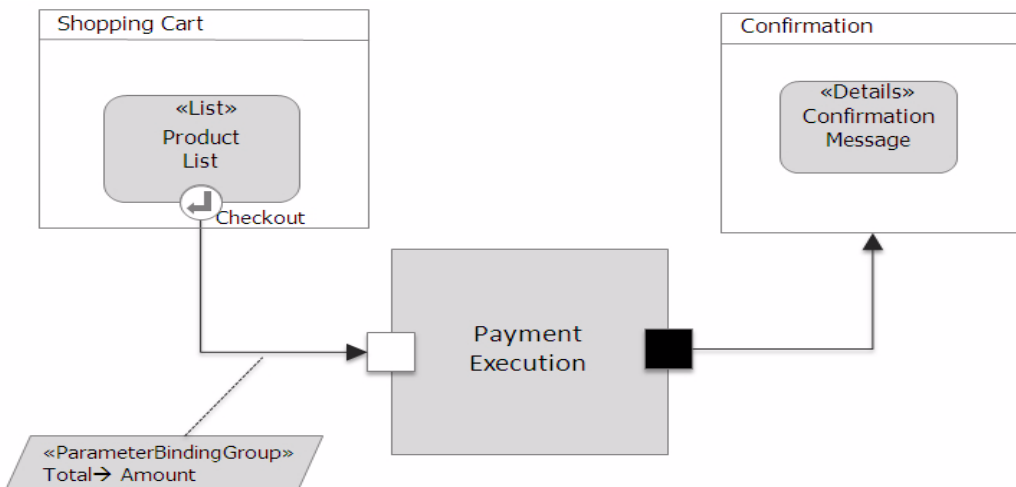

Figure B.17 - IFML Module usage upon the Checkout Event

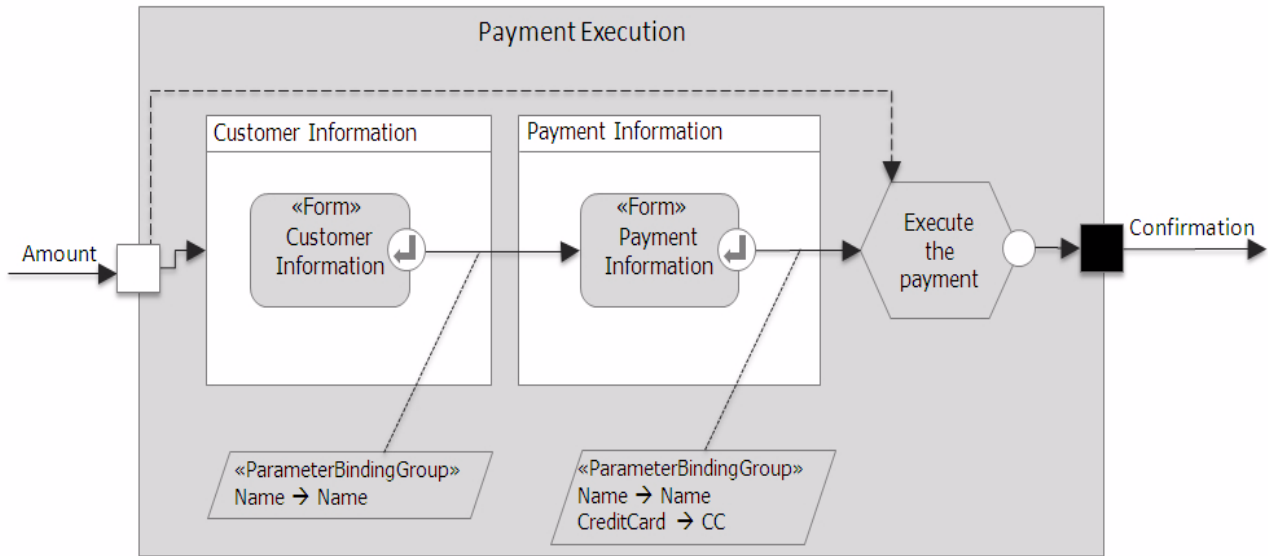

Figure B.18 - Module Definition of Payment Execution

B.5 System Modeling

IFML can be suitably used together with UML models and other OMG standards (e.g., BPM models).

For instance, UML sequence diagrams complement IFML models at the purpose of highlighting sequences of activation of client- and server-side components depending on user interaction events.

In the example, when the customer chooses the option update, the *Browser* sends a message to the *WebServer* with the id of the product and the new quantity, then the *WebServer* updates the shopping cart and returns a confirmation message.

If the user decides to delete all the products previously selected, he clicks the empty cart button, sending the message to the *Browser*. The *Browser* sends a message to the *WebServer* who is in charge of executing the deleting action and return a confirmation message.

When the user is ready to proceed with the payment, notifies the *Browser* who asks to the *WebServer* for the customer information form. After the *WebServer* returns the form, the *Browser* displays it. The next step to continue with the payment is wait for the user to fill out the form with his personal and bank information. When the user submits his information, this is sent to the *WebServer* who asks the *DataServer* to return the customer information in order to verify it. After verifying the customer information, the *WebServer* sends it to a *ExternalBankService* who is in charge of authorize the payment. Finally, after the *WebServer* receives the confirmation from the *ExternalBankService*, sends a confirmation message to the *Browser*.

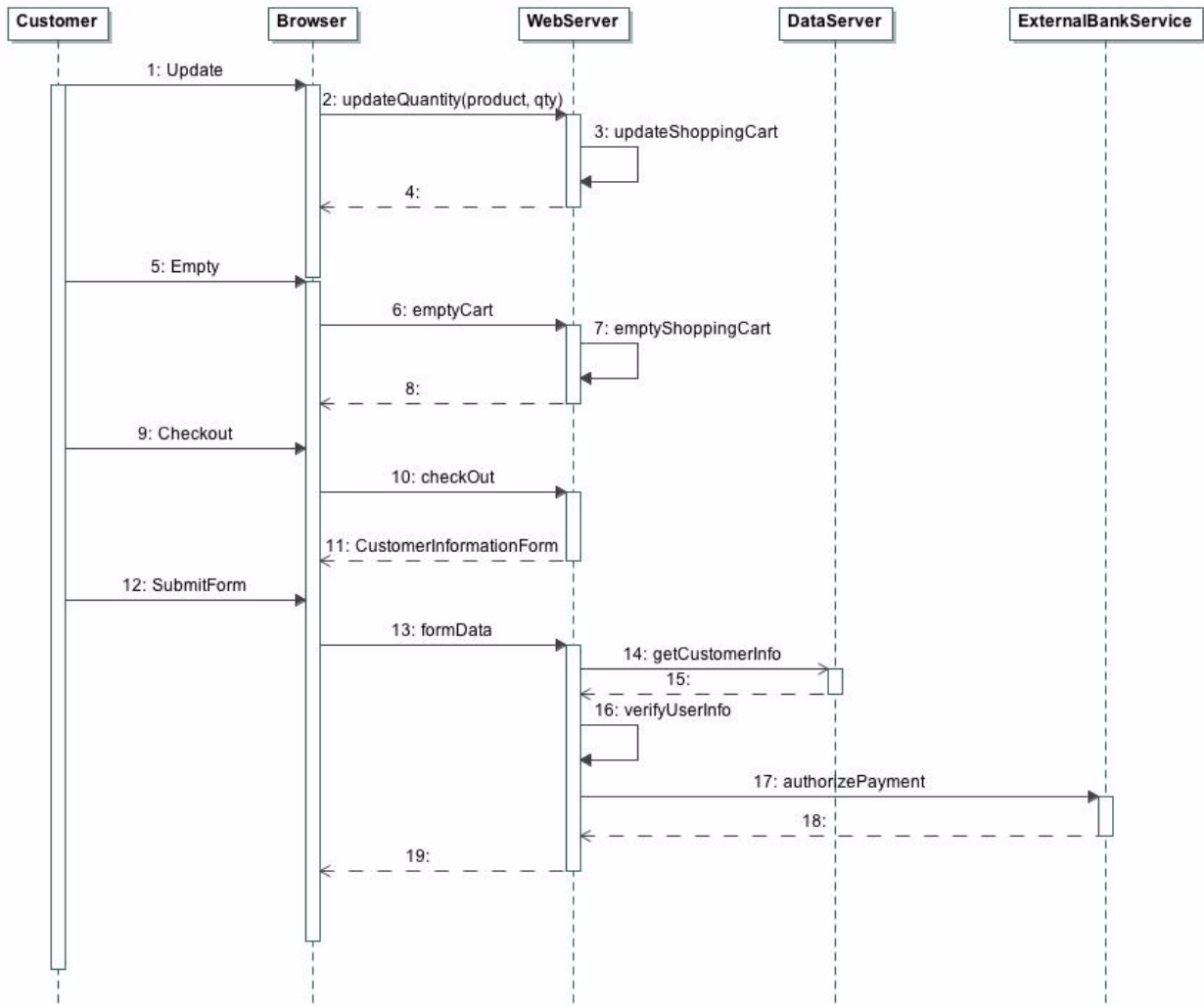

Figure B.19 - Sequence Diagram of the Online Bookstore

Additional diagrams can be used to describe the deployment of the components and other aspects, as shown in Figure B.20.

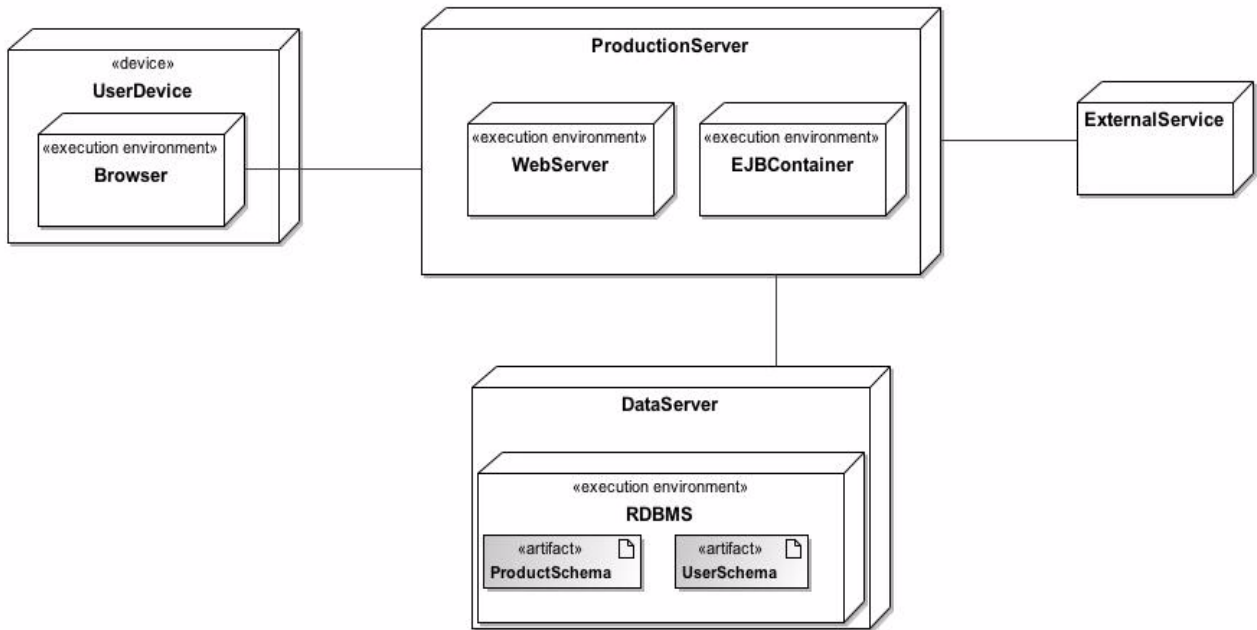

Figure B.20 - Deployment Diagram of the Online Bookstore

Annex C

Mapping to the Windows Presentation Framework

(informative)

C.1 Introduction

This annex describes an example of mapping from IFML to a platform specific language. In particular, this maps the main IFML concepts to the .Net Windows Presentation Framework (WPF).

C.2 The WPF meta-model

Windows Presentation Framework (WPF) is a part of .NET Framework by Microsoft that is meant to be the substitute of the old WinForms UI interface. It brings separation of concerns between interface and code-behind. This is made possible by detaching presentation defined using the XAML language from business logic written in C#.

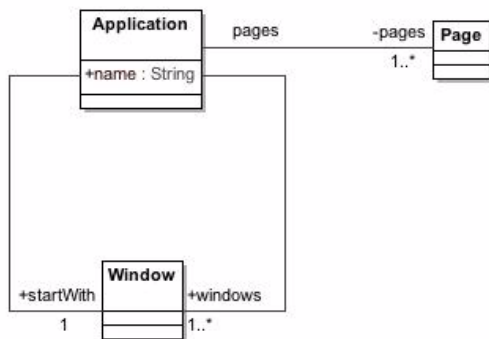

Figure C.1 - WPF metamodel, the Application element

In WPF the interface building blocks are nested. This generates a visual tree that is rendered by the framework.

The target application is modeled by the **Application** class which is the main container of all the elements of the model. It has a start window which is the first one to be opened at startup.

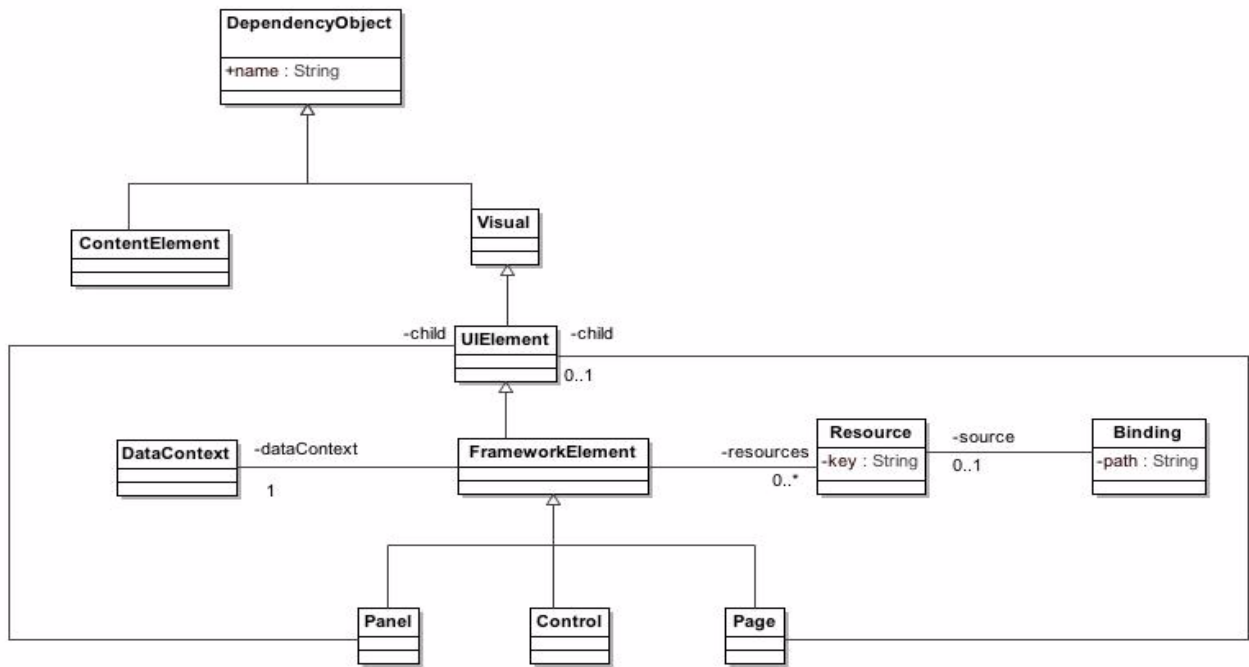

Figure C.2 - WPF metamodel, the DependencyObject element

All the visual objects inherit from **DependencyObject**, a class that allows the attachment of **DependencyProperty**. This lets define properties that may be shared among all the objects of the framework and used as target for bindings.

DependencyObject can be split in two classes, **Visual** and **ContentElement**. Visuals elements are actually rendered by the framework, while **ContentElements** are used to better define the layout of **Visuals**.

The main subclass of **Visual** is **UIElement** which is used as common superclass to define nesting among elements of the UI.

The main subclass of **UIElement** is **FrameworkElement** which is the one that allows to define **Resources** and the **DataContext**. **Resources** are objects related to the **FrameworkElement** organized as a dictionary; they are used by the framework to enhance and better define layout and behavior of the interface. **DataContext** can be associated through a **Binding** to another object to define the source of all the contained **Bindings**, not otherwise specified.

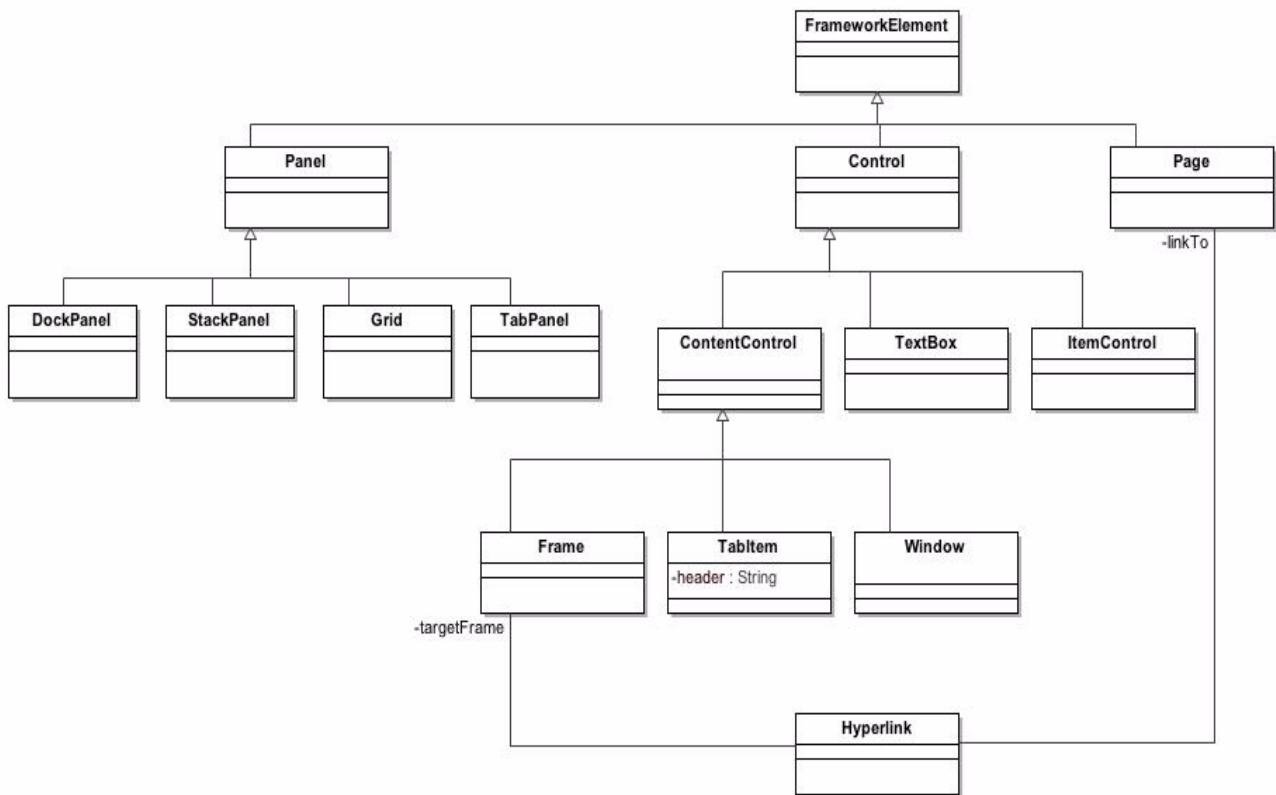

Figure C.3 - WPF metamodel, the FrameworkElement element

FrameworkElements can be divided in **Panels**, **Pages**, and **Controls**.

Panels are UI elements which can contain more than one child. They are classified by behavior:

- **DockPanel**: this container tries to minimize space wasting by expanding all the children to fit all the available space.
- **TabPanel**: it defines a XOR behavior (one by one), allowing to select the child to display through a tabbed header.
- **StackPanel**: it put all the children in a stack, queuing them one after another.
- **Grid**: it features a m by n grid in which all the children are placed. The coordinates of the cell in which the child resides is defined by the attached properties **Grid_Column** and **Grid_Row**.

Pages are one-child containers that allow navigation in a Frame.

Controls include **TextBoxes**, **ContentControls**, and **ItemsControls**.

ContentControls are **Windows**, **UserControls**, **TabItems**, and **Frames**.

- **Windows** are the outer containers of all **UIElements** and have at most one child.
- **TabItems** are one-child containers that allow to define the header used by a **TabPanel**.
- **Frames** are controls that can dynamically navigate through **Pages** using **Hyperlinks** or explicit navigation.

ItemsControls are meant to dynamically define their children applying a template to items to be retrieved by an **ItemsSource**.

C.3 Model to Model Transformation

The IFML model is mapped to a WPF application as one window (the startup one) that contains a frame in which it's possible to navigate within pages.

All the first level ViewContainers are mapped to pages; to bypass the limitation related to the one-child nature of pages in WPF, ViewContainers with one child are mapped directly, while the ones with more children are mapped to pages with a grid as a child.

If there is at least one first level landmark ViewContainer, the main window does not contain directly the frame, but a grid with two children: the frame and a StackPanel that contains Hyperlinks to all the landmarked pages.

All the sub-ViewContainers are mapped to grids; otherwise, if they are XOR, they are mapped to TabPanels whose children are surrounded by TabItems.

All the ViewElementsEvents of type OnSelectEvent that reference a ViewContainer are mapped to a StackPanel containing Hyperlinks to all the pages linked by outgoing NavigationFlows.

List ViewComponents are mapped to ListBoxes: if they have a ViewElementEvent of type OnSelectEvent with an outgoing NavigationFlow that links to another ViewComponent, they are also mapped to a ViewSource bound to a ObservableCollection and to a grid which DataContext is bound to the ViewSource current item.

Forms are mapped to grids; their fields are mapped to TextBox (SimpleField) or ComboBox (SelectField).

Finally since the WPF metamodel is a direct mapping of the entities that compose the .Net framework for desktop applications, a simple model to text transformation is needed for generating a working application.

Annex D

Mapping to Java Swing

(informative)

D.1 Introduction

This annex describes an example of mapping from IFML to Java Swing in order to model very simple Java-based desktop application.

Java Swing is a Model-View-Controller GUI framework for Java application. Thus it allows to develop desktop application in Java decoupling the data viewed from the interface from the user interface controls through which it is viewed.

D.2 The Java Swing meta-model

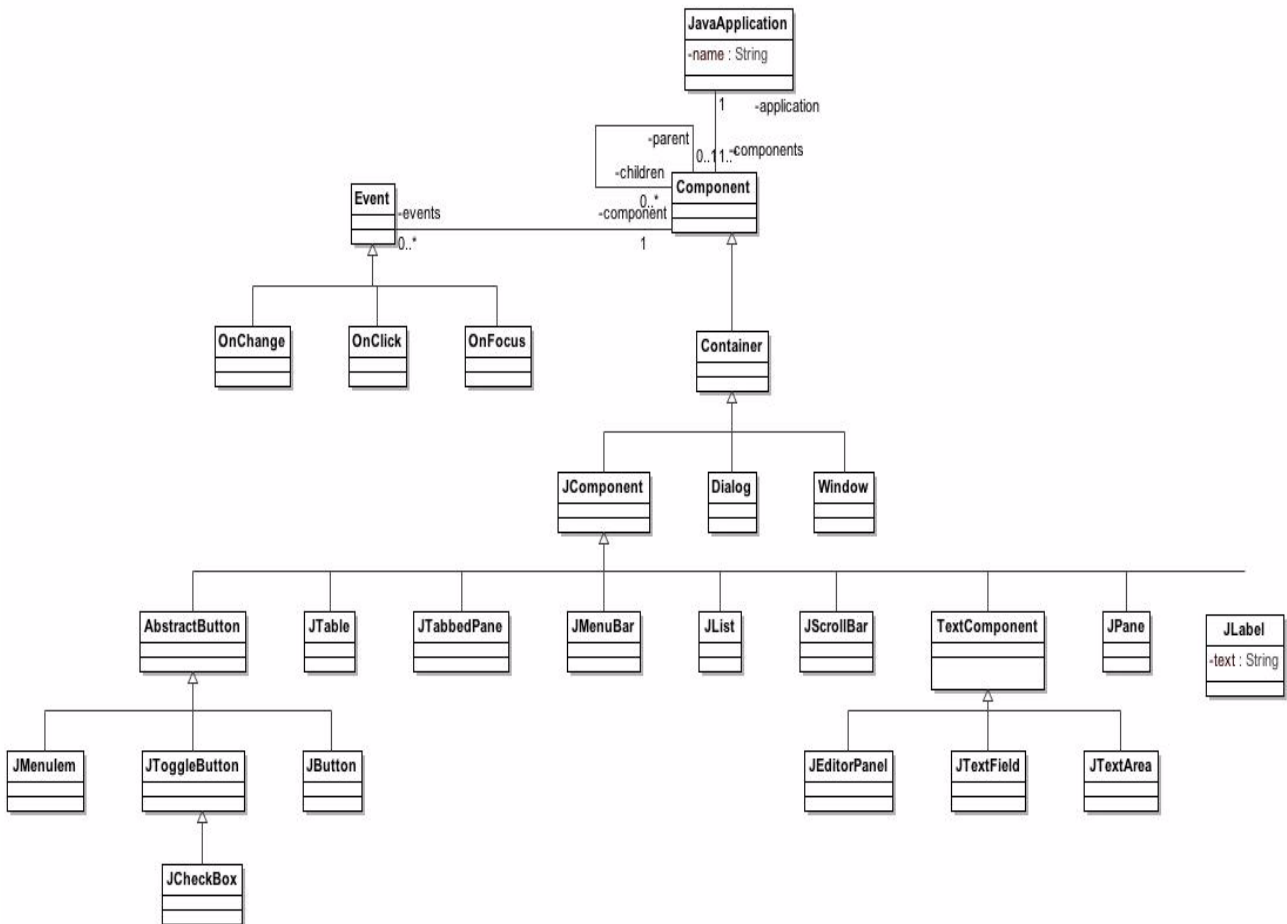

Figure D.1 - The Java Swing metamodel

The desktop application is described by the **JavaApplication** element, which contains all the **Components**.

The **Component** element is the abstract description of the element of a graphical user interface. In particular a **Component** can have a set of child element and a set of **Event** used to enable the user's interaction. Furthermore an **Event** can be associated to a set of **Actions**.

Every **Component** is a **Container**. In particular there are the **Window**, **Dialog**, **JComponent** elements. The first two are pure container while the last comprehends a set of elements that can contain other element or just show data.

The **JComponent** element is then specialized by a set of class that represent the actual GUI elements, for example there are: **AbstractButton**, that model the general button that is more specialized by the class **JToggleButton**, **JButton**, **JmenuItem**; **JTable**, that model a table, **JPane**, **JTabbedPane**, **JScrollBar**, **Jlist**, **Jlabel**, and **TextComponent**, that represent the general component to edit text, which is further specialized by the class **JTextField**, **JTextArea**, and **JeditorPanel**.

D.3 Model to Model Transformation

The IFML model is mapped to a **JavaApplication** element.

Each IFML::Window element is mapped to a **Window** element (in case of a modal window a **Dialog** is created instead).

Each not XOR sub-ViewContainer is mapped as a **JPane** (while a XOR container is mapped as a **JTabbedPane** with each of its child ViewContainer mapped as **JPane** element).

Forms are mapped as **JPane** elements, their fields are then mapped as **JTextField** (in case of SimpleField) or **JCheckBox** in case of multi selection field).

List are mapped as **JList** elements.

Details are mapped as **JTable** showing at each row an attribute of the DataBinding considered.

If events were defined, the corresponding **Event** is created and associated to the correct **Component**. In particular, in case of Select and Submit a **JButton** is created in order to trigger the event. If an Action was defined, a element of type **Action** will be created.

If one or more ViewContainer marked as “landmark” exist, a **JMenuBar** element will be created in each **Window**, containing all the **JMenuItem** element linking to the landmark ViewContainers.

Annex E

Mapping to HTML

(informative)

E.1 Introduction

This annex describes an example of mapping from IFML to HTML in order to model a very simple web application.

E.2 The HTML meta-model

The web application is modeled by the **WebSite** class, which is the main container of all the other elements. In particular a **WebSite** is composed by a set of **Pages**. Then the metamodel describes in details the structure of each element.

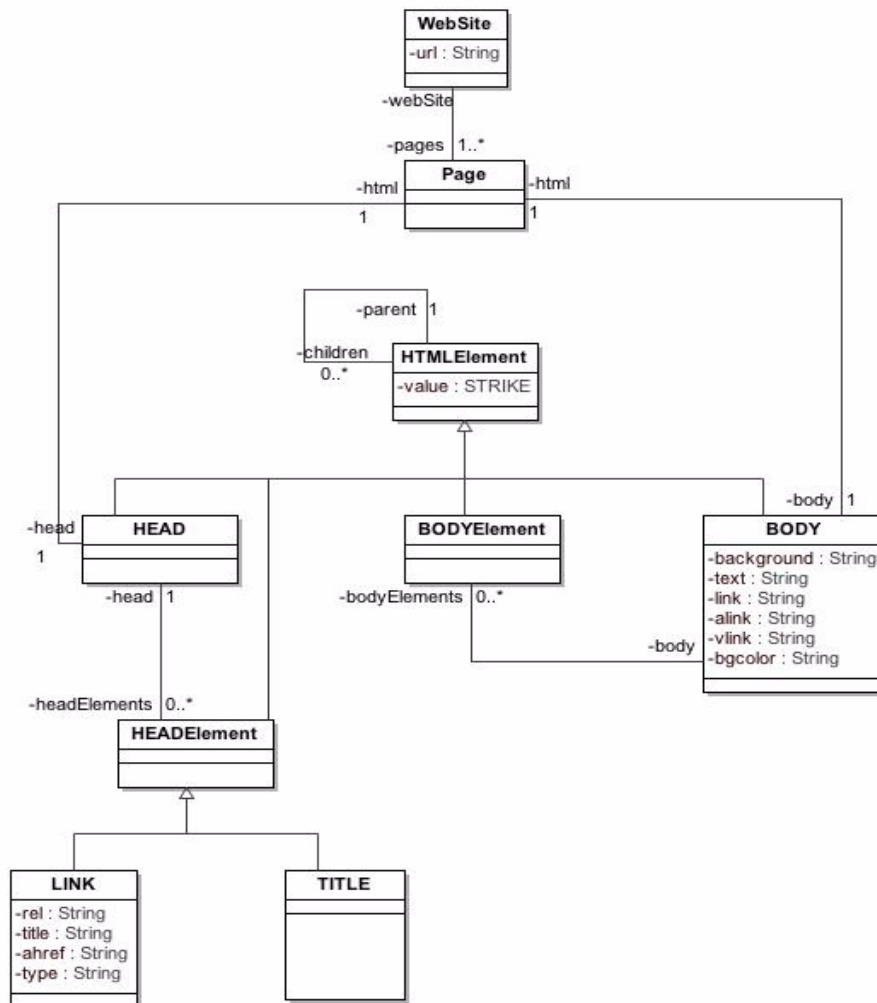

Figure E.1 - HTML metamodel, the Page and Head element

A Page is composed by a **HEAD** and a **BODY** (representing the <head> and <body> tags), the **HEAD** contains a set of **HEADElement** while the **BODY** a set of **BODYElement**, both of them inherit from the general class **HTMLElement** and are abstraction of the concrete html tag.

The **HEADElement** comprehends the **TITLE** and **LINK** tags, while the **BODYElement** comprehend all the html tags used for creating web pages (**P**, **TABLE**, **FORM**, **DIV**, **A** etc.).

In order to allow the nesting of tags, the **HTMLElement** class has a reference to a set of children **HTMLElement**.

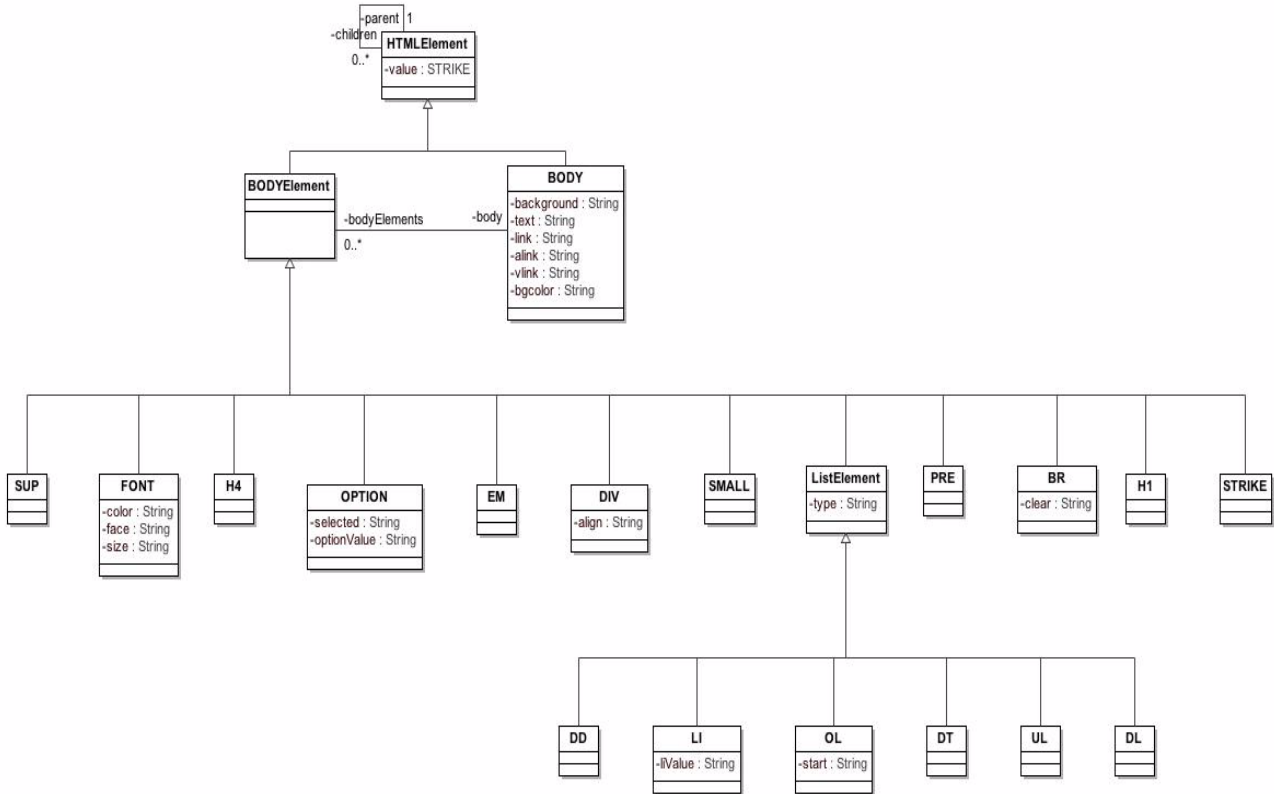

Figure E.2 - HTML metamodel, a fragment of the **BODY** element

E.3 Model to Model Transformation

The IFML model is mapped to a **WebSite** element. Every first level **ViewContainer** is mapped to a **Page** element, in particular the one marked as “home” will be named “index.”

Each sub-**ViewContainer** will be mapped to a **DIV** element.

Each **NavigationFlow** not associated to a **SystemEvent** is mapped to an **A** element. If an **Action** is present, its name will be appended at the end of the link.

Forms are mapped into **FORM** element and their fields are mapped to corresponding **INPUT** elements.

Details are mapped into a **UL – LI** elements, in which each list item is a attribute of the data binding considered.

Lists are mapped into **TABLE**, in which the first row is composed by the field of the corresponding data binding. If an `OnSelectEvent` is associated to the component, then a last column is added which contains an **A** element.

If one or more `ViewContainer` marked as “landmark” exist, a **DIV** element containing all the **A** element linking to the landmark `ViewContainers` will be created in each **Page**.

